

# FireNET *Plus*

## Analog Addressable Fire Alarm System

### Installation and Operation Manual

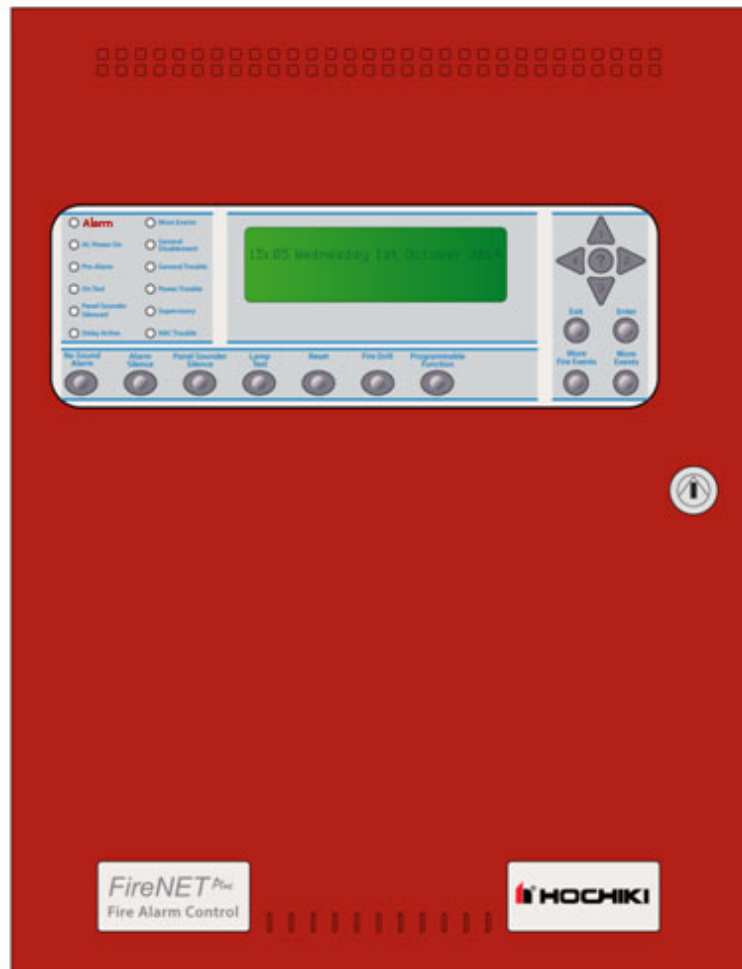

Hochiki America Corporation  
7051 Village Drive, Suite 100  
Buena Park, CA 90621-2268  
714.522.2246 Corporate Headquarters  
800.845.6692 Technical Support  
<http://www.hochiki.com>

Version 1.09  
Created: 12/23/08  
Updated: June 2023

PN# 1700-10840

# Table of Contents

---

Table of Contents.....	2
Prefix – Programming Compliance with UL864 9 <sup>th</sup> Edition .....	6
<b>Section 1 – Introduction</b>	
.....	7
1.1 Basic Features.....	7
1.2 System Devices and Equipment.....	8
1.2A System Devices BOSCH .....	10
Accessories .....	10
1.2B System Devices Silent Knight .....	11
Accessories .....	11
1.2C System Devices Fike.....	12
1.2D System Devices NAPCO .....	13
1.2E System Devices VES.....	14
1.2.1 System Replacement Parts .....	16
1.2.2 Master Part Number Schema .....	17
1.3 Limitations of Fire Alarm Systems .....	18
1.4 Agency Listings, Approvals, Requirements .....	21
1.4.1 Federal Communications Commission (FCC) .....	21
1.4.2 Underwriters Laboratories (UL) .....	21
1.4.3 National Fire Protection Association (NFPA).....	21
<b>Section 2 – Control Panel Installation</b>	
.....	22
2.1 What’s in the Box?.....	22
2.2 Environmental Specifications .....	22
2.3 Control Panel Layout.....	23
2.3.1 Front Panel Controls and Display .....	23
2.3.2 Enclosure and Panel Layout.....	24
2.4 Mounting the Control Panel .....	25
2.5 Wiring Specifications .....	25
2.5.1 Suggested Routing of AC Power .....	26
2.6 Battery Calculations.....	27
2.7 Electrical Ratings.....	29
2.8 Specifications .....	31
<b>Section 3 - Power Supply and Main Control Unit Connections</b>	
.....	32
3.1 AC Power Connection .....	32
3.2 Battery Connection .....	32
3.3 Auxiliary Power Connection.....	34
3.4 Notification Appliance Circuit Connection.....	35
3.5 Relay Output Connection .....	36
3.6 Phone Line Connections (FNP-1127D and FNP-1127DE only) .....	37

**Section 4 – Expander Board Installation**

---

.....38

- 4.1 Compatible Expander Boards.....38
- 4.2 General Installation of RS-485 Bus Devices.....38
  - 4.2.1 Wiring Distance and Mounting Locations.....38
  - 4.2.2 Addressing.....39
  - 4.2.3 Terminating.....39
  - 4.2.4 Power Connections .....40
  - 4.2.5 COMMS Connection.....40
- 4.3 FN-4127-IO - Input / Output Board .....41
  - 4.3.1 Configuring Inputs .....41
  - 4.3.2 Configuring Outputs.....42
  - 4.3.3 LED Indicators .....43
- 4.6 FNP-1127-SLC – SLC Loop Expander.....44
  - 4.6.1 Installation of the FNP-1127-SLC .....44
- 4.7 FN-LCD-S Serial Liquid Crystal Display Annunciator .....45
  - 4.7.1 Installation of the FN-LCD-S.....45

**Section 5 – SLC Device Installation**

---

.....48

- 5.1 Compatible SLC Devices.....48
- 5.2 Number of Devices .....49
- 5.3 SLC Loop Wiring .....50
  - 5.3.1 Class B SLC Loop Wiring Distance .....51
  - 5.3.2 Class A SLC Loop Wiring Distance .....53
- 5.4 Addressing Devices.....55
  - 5.4.1 Detector Addressing .....57
  - 5.4.2 4” Modules and AMS Addressing .....57
  - 5.4.3 Mini Module Addressing .....58
- 5.5 Smoke and Heat Detector Wiring .....59
  - 5.5.1 ACD-V CO Multi-Sensor Configuration.....60
- 5.6 Analog Duct Detector Wiring .....61
  - 5.6.1 DH98-A Analog Duct Detector.....62
  - 5.6.2 DH98-AR Analog Duct Detector with Relay.....62
- 5.7 FRCME-4 Input Module Wiring.....64
- 5.8 FRCME-M Mini Input Module (w/ Terminal Blocks).....65
- 5.9 FRCMA / FRCMA-I Input Module .....66
- NOTE: For Sections 5.7, 5.8, and 5.9 common for all FRCM devices.....67
- 5.10 R2M Dual Relay Module Wiring.....68
- 5.11 SOM Supervised Output Module .....69
- 5.12 SOM-A / SOM-AI Supervised Class A Output Module .....70
- 5.13 SOM-R Supervised Output Module (Preaction Sprinkler Systems).....72
- 5.14 CZM Conventional Zone Module .....76
- 5.15 DIMM Dual Input Monitor Module .....77
- 5.16 SCI Short Circuit Isolator Module .....78
  - 5.16.1 Class A Operation .....79
  - 5.16.2 Class B Operation .....80
- 5.17 ASB & ASBL Analog Sounder Base .....81

5.18 AMS Addressable Manual Pull-Station.....	82
---	----

**Section 6 - Network Connections**

---

.....	<b>83</b>
6.1 Compatible Network Devices.....	83
6.1.1 FN-4127-NIC Network Interface Card .....	84

**Section 7 - Basic Front Panel Operations and Programming.....89**

**(Access Level 1, 2, and Real-Time Operation)**

---

.....	<b>89</b>
7.1 Operating Modes .....	90
7.1.1 Access Level 1 .....	90
7.1.2 Access Level 2 .....	90
7.1.3 Access Level 3 .....	90
7.2 Access Level 1 Operations .....	91
7.2.1 Performing a Lamp Test .....	91
7.2.2 More Fire Events .....	91
7.2.3 More Events .....	91
7.2.4 Menu Navigation (Up, Down, Left, Right Arrows, Enter / Exit Buttons).....	91
7.2.5 Help (?).....	91
7.3 Access Level 2 Operations .....	92
7.3.1 Entering Access Level 2 .....	92
7.3.2 Silencing an Alarm.....	92
7.3.3 Resounding an Alarm .....	92
7.3.4 Resetting an Alarm .....	93
7.3.5 Initiating a Fire Drill .....	93
7.3.6 Silence the Panel Sounder .....	93
7.4 Advanced Access Level 2 Operations .....	94
7.4.1 Access Level 2 Main Menu.....	94
7.4.2 Disablements.....	94
7.4.3 View Devices .....	96
7.4.4 Test Zones.....	96
7.4.5 Set System Time .....	96
7.5 Panel Operation.....	98
7.5.1 Fire Condition .....	98
7.5.2 CO Condition .....	99
7.5.3 Trouble Condition .....	99
7.5.4 Supervisory Condition.....	100
7.6 DACT Operation and Event Reporting Codes (FNP-1127D only) .....	102
7.61 Compatible Receivers (DACRs) .....	102
7.62 Phone Line and Phone Number Selection.....	102
7.63 Phone Line Supervision.....	103
7.64 Report Groups .....	104
7.65 Communication Failure.....	105
7.66 AC Fail Reporting .....	105
7.7 Event Reporting Codes .....	105

## **Section 8 - Advanced Front Panel Operations and Programming (Access Level 3)**

.....	<b>109</b>
8.1 Access Level Overview .....	109
8.1.1 Entering Access Level 3 .....	109
8.2 Access Level 3 Menu .....	110
8.2.1 Edit Configuration .....	110
8.2.4 Print Configuration.....	121
8.2.6 Loop Data Test.....	122

## **Section 9 - Testing and Troubleshooting**

.....	<b>123</b>
9.1 One Man Walk Test - TEST ZONES .....	123
9.2 View / Print Event Log .....	124
9.2.1 View Event Log.....	124
9.2.2 Print Event Log (Only available on special equipped panels).....	125
9.2.3 Clear Event Log.....	126
9.3 Loop Data Test.....	127
9.4 Troubleshooting.....	129
9.5 Trouble Conditions .....	130

## **Section 10 - Installation Records**

.....	<b>132</b>
10.1 SLC Loop Point Record.....	132
10.2 RS485 Bus Device Record.....	132
10.3 Network Node Device Record .....	132

## **Appendix A - Compatible Devices**

.....	<b>145</b>
A.1 Two-Wire Smoke Detectors .....	145
A.2 Reserved for Future Use .....	145
A.3 Compatible Notification Appliances.....	146
A.3.1 Gentex Compatible NAC Devices .....	147
A.3.2 Amseco Compatible NAC Devices.....	147
A.3.3 Wheelock Compatible NAC Devices .....	149
A.3.4 System Sensor Compatible NAC Devices.....	151
A.4 Compatible 24VDC Devices.....	152
A.5 Changing the Power Supply to 240VAC operation.....	153

<b>Appendix C - WARRANTY.....</b>	<b>156</b>
-----------------------------------	------------

## Prefix – Programming Compliance with UL864 9<sup>th</sup> Edition

Notice to Users, Installers, Authorities Having Jurisdiction, and other involved parties			
This product incorporates field-programmable software. In order for the product to comply with the requirements in the Standard for Control Units and Accessories for Fire Alarm Systems, UL 864 9 <sup>th</sup> Edition, certain programming features or options must be limited to specific values or not used at all as indicated below.			
Program Feature or Option	Permitted in UL 864? (Y/N)	Possible settings	Settings permitted in UL864
AC Fail Delay	Yes	0 – 180 minutes	60 – 180 minutes
Alarm Verification	Yes	5 – 60 seconds	60 second setting
Disable Buzzer	Yes	Enable/Disable	Enable
Disable Ground Trouble	Yes	Enable/Disable	Enable
Set Buzzer Silence Access Level	Yes	1 or 2	2
“Waterflow Alarm” and “General Purpose” Device Type	No	0 – 120 seconds	0 seconds
Disable SOM-R	No	Enable/Disable	None
Sensors Set to Supervisory	No	Fire / Supervisory	Fire

# Section 1 – Introduction

---

The FireNET Plus is an analog addressable fire alarm system that meets the requirements of UL 864 9<sup>th</sup> Edition.

## 1.1 Basic Features

---

- ❑ The basic FireNET Plus control panel includes one SLC (Signaling Line Circuit) loop. The loop is capable of supporting 127 analog addressable points which can be any combination of sensors and modules. One additional SLC loop can be added to the panel increasing the analog addressable point capacity to 254. When analog sounder bases are used, the upper addresses 128 – 254 are allocated to increase loop capacity to 254 analog addressable points. This doubles the analog addressable point capacity of the panel. The combination of analog addressable points derived from sensors, modules, and sounder bases cannot exceed 800 addresses and sub-addresses maximum.
- ❑ Up to 4.0 amps of power is available to drive the system, SLC loops, notification appliances, and auxiliary equipment.
- ❑ Two Class B notification appliance circuits rated at 2.3 amps each (see Section 2.7 and 2.8 for additional details regarding NAC circuit ratings).
- ❑ Three programmable Form C relays are built-in to the control panel.
- ❑ 500 network-wide zones for device and circuit grouping.
- ❑ Analog Smoke Detector Features:
  - Automatic Drift Compensation
  - Maintenance Alert
  - Adjustable Day/Night Sensitivity
  - Calibration checking meets sensitivity test requirements of NFPA 72.
- ❑ Auto-Learn utility identifies system devices, which makes initial system start-up easier.
- ❑ An 8 line by 40 character graphic LCD display provides a flexible and intuitive operator interface (320 characters total).
- ❑ Help screens are available from the front panel and annunciator user interface to assist in programming and operation.
- ❑ 512 additional points can be added to the system using the FN4127-IO 16 channel input/output boards. Each of these points can be programmed individually to be an input or low current output. These points are for secondary use only.

## 1.2 System Devices and Equipment

The following boards, expanders and devices are available from Hochiki America Corp. to be used with the FireNET Plus analog addressable fire alarm system. For a complete description and installation instructions of each product, please see the appropriate section of this manual and the literature supplied with the device itself.

Model	Description
<b>Control Panels</b>	
FNP-1127US00RS110	Analog/Addressable Fire Alarm Control Panel Red 110v (1 SLC Loop, not expandable)
FNP-1127US20RS110	Analog/Addressable Fire Alarm Control Panel with Integrated DACT Red 110v (1 SLC Loop, not expandable)
FNP-1127US0ERS110	Analog/Addressable Fire Alarm Control Panel Red 110v (1 SLC Loop, expandable to 2 SLC Loops)
FNP-1127US2ERS110	Analog/Addressable Fire Alarm Control Panel with Integrated DACT Red 110v (1 SLC Loop, expandable to 2 SLC Loops)
<b>NOTE:</b> There are several ordering models (i.e. 120/240VAC, colors, etc.) see page 17. Hochiki America's ordering department will establish exact model and configuration at time of order. Different ordering models are also reflected on the FireNET Plus product datasheets.	
<b>Control Panel Expanders</b>	
FN-4127-NIC	Network Interface Card
FNP-1127-SLC	SLC Loop Expander Card
FN-4127-IO	16 Channel Input Output Board
<b>Annunciators</b>	
FN-LCD-S	Serial LCD Annunciator
FNP-LED	Graphix LED Annunciator
<b>Releasing Modules</b>	
XT+1R, XT+1G, XT+2R, XT+1G	Multi Area Releasing Module(s)
<b>SLC Loop Devices</b>	
ALK-V	Smoke Detector - Photoelectric
ALK-V2	Smoke Detector - Photoelectric
ALG-V	Smoke Detector - Photoelectric
ALN-V	Smoke Detector - Photoelectric
ALN-DH	Smoke Detector - Photoelectric for use with DH-100-A
ALO-V	Smoke Detector - Photoelectric*
AIE-EA	Smoke Detector - Ionization
ATG-EA	Heat Detector - Fixed Temp
ATJ-EA	Heat Detector - Fixed Temp/Rate of Rise
ACA-V	Multi-Criteria Detector - Smoke/Heat
ACC-V	Multi-Criteria Detector - Smoke/Heat
ACB-EA, ACB-EAW	Heat Detector - Fixed Temp/Rate of Rise (ACB-EAW Weather Proof)



ACD-V	Multi-Criteria Detector - Smoke/Heat/CO
YBN-NSA-4	Detector Base 4"
YBN-NSA-47	Detector Base 4" - 7th Edition
HSB-NSA-6	Detector Base 6" Base for Analog Sensors
HSB-NSA-67	Detector Base 6" - 7th Edition
DH98-A	Duct Smoke Detector - ALG
DH98-AR	Duct Smoke Detector - ALG, Relays
DH99-A	Duct Smoke Detector - ALK
DH99-AR	Duct Smoke Detector - ALK, Relays
DH-100-A	Duct Smoke Detector - ALN
MS-RA, MS-RA/R, MS-KA/R	Remote Test Station for DH98A & DH98AR
FRCME-4	Contact Module - 4" Cover Plate
FRCME-M	Contact Module - Terminals, Miniature
FRCMA, FRCMA-I	Contact Module - Class A (FRCMA-I has built-in SCI)
SOM	Supervised Output Module
SOM-A, SOM-AI	Supervised Output Module - Class A (SOM-AI has built-in SCI)
SOM-R	Supervised Output Module Release w/ Disable Keyswitch
CLIM-1	Current Loop Input Module - Single
CLIM-2	Current Loop Input Module - Double
R2M	Dual Relay Module - 1A @ 30 VDC / 0.5A @ 120 VAC
R2ML, R2ML-I	Dual Relay Module - 2A @ 30 VDC / 0.5A @ 120 VAC (R2ML-I has built-in SCI)
R2MH, R2MH-I	Dual Relay Module - 8A @ 30 VDC / 4.8A @ 250 VAC (R2MH-I has built-in SCI)
SCI	Short Circuit Isolator Module
SCI-B47	Short Circuit Isolator Base 4" - 7th Edition
SCI-B67	Short Circuit Isolator Base 6" - 7th Edition
DIMM	Dual Input Monitor Module
CZM	Conventional Zone Module
ASB	Sounder Base - Aux Power
ASBL	Sounder Base - Low Frequency, Aux Power
ASB7	Sounder Base - Aux Power, 7th Edition
ASBL7	Low Frequency Sounder base - Aux Power, 7th Edition
AMS/KL/LP	Addressable Manual Pull-Station
<b>Accessories</b>	
TCH-B100-NS	Hand-held Programmer
FN-ACC	Battery/Accessory Enclosure (houses up to 33AH size batteries)
FNP-ETR	Enclosure Trim Ring for Panel Flush Mount

\* ALO-V is not compatible with 6th Edition bases.

## 1.2A System Devices BOSCH

---

The following boards, expanders and devices are available from BOSCH to be used with the FireNET Plus analog addressable fire alarm system. For a complete description and installation instructions of each product, please see the appropriate section of this manual and the literature supplied with the device itself.

<b>Model</b>	<b>Description</b>
<b>SLC Loop Devices</b>	
D323A	Analog Photoelectric Smoke Sensor
D324A	Analog Ionization Smoke Sensor
D322A	Analog Heat Sensor
D336A	4" Base for Analog Sensors
D321A	6" Base for Analog Sensors
D331A	Analog Duct Smoke Detector
D332A	Analog Duct Smoke Detector w/Relay
D326A	Input Module 4" Box Mount
D339A	Mini Input Module w/ Terminal Block
D327A	Supervised Output Module
D335A	Dual Relay Module
D333A	Short Circuit Isolator Module
<b>Accessories</b>	
D5070	Hand-held Programmer

## 1.2B System Devices Silent Knight

---

The following devices are available from Silent Knight to be used with the FireNET Plus analog addressable fire alarm system. For a complete description and installation instructions of each product, please see the appropriate section of this manual and the literature supplied with the device itself.

<b>Model</b>	<b>Description</b>
<b>SLC Loop Devices</b>	
SD505-APS	Analog Photoelectric Smoke Sensor
SD505-PHOTO	Analog Photoelectric Smoke Sensor
SD505-AIS	Analog Ionization Smoke Sensor
SD505-AHS	Analog Heat Sensor
SD505-HEAT	Analog Heat Sensor
SD505-4AB	4" Base for Analog Sensors
SD505-6AB	6" Base for Analog Sensors
SD505-DUCT	Analog Duct Smoke Detector
SD505-DUCTR	Analog Duct Smoke Detector
<b>Accessories</b>	
SD505-DTS-K	Remote Test Switch

## 1.2C System Devices Fike

---

The following devices are available from Fike to be used with the FireNET Plus analog addressable fire alarm system. For a complete description and installation instructions of each product, please see the appropriate section of this manual and the literature supplied with the device itself.

Model	Description
<b>SLC Loop Devices</b>	
63-1021	Analog Photoelectric Smoke Sensor
67-1032	Analog Ionization Smoke Sensor
60-1028	Analog Heat Sensor
63-1020	4" Base for Analog Sensors
63-1023	6" Base for Analog Sensors
63-028/63-029	Analog Duct Smoke Detector
55-019/55-020	Fast Response Contact Monitor Module
55-023	Dual Relay Module
55-021	Supervised Output Module

NOTE: The 55-019 has been tested to UL 864 8<sup>th</sup> edition. However, the 55-019 will operate with the 9<sup>th</sup> edition listed FireNET Plus Fire Alarm Control panel. Therefore, it may be used in panel retrofit applications, subject to approval by your AHJ.

## 1.2D System Devices NAPCO

---

*The following devices are manufactured by Hochiki America for Napco*

The following devices are available from NAPCO to be used with the FireNET Plus analog addressable fire alarm system. For a complete description and installation instructions of each product, please see the appropriate section of this manual and the literature supplied with the device itself.

<b>Model</b>	<b>Description</b>
<b>SLC Loop Devices</b>	
FWC-FSLC-SMK	Analog Photoelectric Smoke Sensor
FWC-FSLC-HEAT	Analog Heat Sensor
FWC-FSLC-SMK4B	4" Base for Analog Sensors
FWC-FSLC-SMK6B	6" Base for Analog Sensors
FWC-FSLC-DUCT	Analog Duct Smoke Detector
FWC-FSLC-EZM1	Fast Response Contact Monitor Module
FWC-FSLC-EZM1B	Fast Response Mini Contact Monitor Module
FWC-FSLC-EZM2	Dual Input Monitor Module
FWC-FSLC-RM2	Dual Relay Module
FWC-FSLC-SOM1	Supervised Output Module
FWC-FSLC- PULL	Addressable Manual Pull Station
FWC-FSLC-ISO	Short Circuit Isolator Module

NOTE: The FWC-FSLC-EZM1 has been tested to UL 864 8<sup>th</sup> edition. However, FWC-FSLC-EZM1 will operate with the 9<sup>th</sup> edition listed FireNET Plus Fire Alarm Control panel. Therefore, it may be used in panel retrofit applications, subject to approval by your AHJ.

## 1.2E System Devices VES

The following devices are available from VES to be used with the FireNET Plus analog addressable fire alarm system. For a complete description and installation instructions of each product, please see the appropriate section of this manual and the literature supplied with the device itself.

VES Models	Hochiki Models	Loop Devices
VF2001-00	AIE-EA	Smoke Detector - Ionization
VF2002-00	ALG-V	Smoke Detector - Photoelectric
VF2003-00	ATG-EA	Heat Detector - Fixed Temp
VF2004-00	ALG-DH	Smoke Detector - Photoelectric for use with DH-98-A/DH-98-AR
VF2005-00	ALK-V	Smoke Detector - Photoelectric
VF2008-00	ACA-V	Multi-Criteria Detector - Smoke/Heat
VF2010-00	ATJ-EA	Heat Detector - Fixed Temp/Rate of Rise
VF2011-00	ALN-V	Smoke Detector - Photoelectric
VF2012-00	ACC-V	Multi-Criteria Detector - Smoke/Heat
VF2014-00	ACD-V	Multi-Criteria Detector - Smoke/Heat/CO
VF3001-00	ALG-DH	Smoke Detector - Photoelectric for use with DH-98-A/DH-98-AR
VF3002-00	SG-32BK2-VG-B	Addressable Manual Pull Station - Single-Action
VF3029-00	AMS-KL-LP	Addressable Manual Pull Station - Dual-Action w/ Cat 30 Key
VF3030-00	AMS-LP	Addressable Manual Pull Station - Dual-Action, Hex Key
VF3031-00	AMS	Addressable Manual Pull Station, Single-Action, Hex Key
VF3032-00	AMS-KL	Addressable Manual Pull Station - Single-Action w/ Cat 30 Key
VF5001-00	DH-98-A	Duct Smoke Detector - ALG
VF5002-00	DH-98-AR	Duct Smoke Detector - ALG, Relays
VF5013-00	DH-99-A	Duct Smoke Detector - ALK
VF5014-00	DH-99-AR	Duct Smoke Detector - ALK, Relays
VF7001-00	YBN-NSA-4	Detector Base 4"
VF7002-00	HSB-NSA-6	Detector Base 6"
VF7008-00	ASB	Sounder Base - Aux Power
VF7005-00	ASBL	Sounder Base - Low Frequency, Aux Power

VES Models	Hochiki Models	Loop Devices
VF6001-00	FRCME-S	Contact Module - Terminals
VF6002-00	FRCME-4	Contact Module - 4" Cover Plate
VF6003-00	SCI	Short Circuit Isolator Module
VF6004-00	SOM	Supervised Output Module
VF6005-00	R2M	Dual Relay Module
VF6007-00	DIMM	Dual Contact Module - 4" Cover Plate
VF6011-00	CZM	Conventional Zone Module
VF6013-00	FRCME-P	Contact Module - Pigtails
VF6020-00	FRCMA	Contact Module - Class A
VF6021-00	FRCMA-I	Contact Module - Class A, Short Circuit Isolator
VF6022-00	FRCMA-P	Contact Module - Class A, Pigtails
VF6023-00	FRCMA-PI	Contact Module - Class A, Pigtails & Short Circuit Isolator
VF6024-00	FRCME-M	Contact Module - Terminals, Miniature
VF6040-00	SOM-A	Supervised Output Module - Class A
VF6041-00	SOM-AI	Supervised Output Module - Class A, Short Circuit Isolator
VF6052-00	R2ML	Dual Relay Module - 2A @ 30 VDC / 0.5A @ 120 VAC
VF6053-00	R2ML-I	Dual Relay Module - 2A @ 30 VDC / 0.5A @ 120 VAC, Isolator
VF6054-00	R2MH	Dual Relay Module - 8A @ 30 VDC / 4.8A @ 250 VAC
VF6055-00	R2MH-I	Dual Relay Module - 8A @ 30 VDC / 4.8A @ 250 VAC, Isolator
VF5020-00	MS-RA	Remote Test Station for Duct Detectors - Alarm LED
VF6056-00	CLIM-1	Current Loop Input Module - Single
VF6057-00	CLIM-2	Current Loop Input Module - Double
VF5021-00	MS-RA/R	Remote Test Station for Duct Detectors - Alarm LED w/ Reset Button
VF5023-00	MS-KA/R	Remote Test Station for Duct Detectors - Alarm LED w/ Reset Key Switch

NOTE: The VF6001 has been tested to UL 864 8<sup>th</sup> edition. However, VF6001 will operate with the 9<sup>th</sup> edition listed FireNET Plus Fire Alarm Control panel. Therefore, it may be used in panel retrofit applications, subject to approval by your AHJ.

## 1.2.1 System Replacement Parts

<b>Control Panel Repair / Replacement Parts</b>	
FNP-1127-BO	FireNET 1127 Control Unit Board Only
FNP-1127D-BO	FireNET 1127 Control Unit Board Only, with integrated DACT
FNP-1127E-BO	FireNET 1127 Control Unit Board Only, expandable
FNP-1127DE-BO	FireNET 1127 Control Unit Board Only, expandable with integrated DACT
FNP-1127-ENC	FireNET 1127 Enclosure Complete
FNP-1127-ENC-DO	FireNET 1127 Enclosure Door Only
FNP-1127-ENC-BC	FireNET 1127 Enclosure Back-Can Only
FNP-1127-MP	FireNET 1127 Panel Mounting Plate
FN-KEY	FireNET Enclosure Key Lock
FN-PBS	FireNET Panel Bonding Strap
FN-PGB	FireNET Panel Grounding Block
FN-EOL	FireNET Panel EOLR (package)
FN-STO	FireNET Panel Standoffs (for panel covers)
FN-FUS	FireNET Main AC Input Fuse
FN-FUS-BATT	FireNET Battery Input Fuse
FN-BLJ	FireNET Battery Leads & Jumper
FNP-1127-MAN	FireNET Installation Manual
FNP-1127-PDL	FireNET Panel Door Label
FN-LSW	Loop Explorer Software CD
FN-X187	Programming Cable (Standard)
FN-S187	Programming Cable (Jacketed)
FN-SKDK	Spare Keys for Door Keyswitch
FN-SKCK	Spare Keys for Controls Keyswitch
FN-ECK	Enable Controls Keyswitch
FN-BLE	Battery Leads for Accessory Enclosure (extended length 3.28ft)
FN-LCD-S-BO	Serial Annunciator Control Unit Board Only (K6017)
FN-LCD-S-BB	Serial Annunciator Back-box
FN-EBS	Expansion Boards Standoffs (SLC board & I/O board stacking)

\*NOTE: 240VAC option available



## 1.22 Master Part Number Schema

Hochiki America Panel PN Breakdown		
<b>FNP -2 127 US00C</b>		
		→ This is panel Color & Style
		→ This is whether panel is expandable
		→ Feature 1 [Network Card / Dialer]
		→ This is the Language
		→ This is the Device Range
		→ This is the number of loops on the product
		→ This is the product style
Option Ranges		
Option Type	Valid Entries	Description
Product Style	FNP	FireNET Plus
Loops	1	1 Loop Hochiki Protocol
	2	2 Loop Hochiki Protocol
Device Range	127	127 Points
Language	US	US English
	SP	Spanish
Feature 1 Network Card, Dialer	0	None
	1	Network Card
	2	Internal Dialer
	4	Internal Dialer & Network Card
Expandable	0	Non-Expandable
	E	Expandable
Color	R	Red
	C	Charcoal
	G	Gray
Style	S	Standard
	D	Plexi Window
	L	Limited Aperature

## 1.3 Limitations of Fire Alarm Systems

---

Follow Recommended Installation Guidelines: To achieve early fire detection, fire detection sensors should be installed in all rooms and areas of a house, apartment, or building in accordance with the recommendations of the National Fire Protection Association Standard 72 (NFPA 72), manufacturer's recommendations, state and local codes, and the recommendations contained in Guide for the Proper Use of System Smoke Detectors, which is made available at no charge to all installing dealers. Generally, the standards and recommendations include the following (but installers should refer to the specific guidelines above before installing):

- Sleeping Rooms: Smoke detectors should be installed in every sleeping room.
- Hallways: More than one smoke detector should be installed in a hallway if it is more than 30 feet long.
- At least Two Smoke Detectors: There should never be less than two smoke detectors per apartment or residence.
- Smoke Detectors in Alarm, Electrical, or Phone Locations: Smoke detectors should be located in any room where an alarm control is located or an alarm control connects to an electrical source or phone line. If detectors are not so located, a fire within the room could prevent the alarm control from reporting a fire.
- Notification Systems: All fire alarm systems require notification devices, including sirens, bells, horns, and/or strobes. In residential applications, each automatic alarm initiating device when activated should cause the operation of alarm notification device that should be clearly audible in all bedrooms over ambient or background noise levels (at least 15dB above noise) with all intervening doors closed.
- Alarm in Every Bedroom and Level of Residence: A smoke detector with an integral sounder (smoke alarm) should be located in every bedroom and an additional notification device should be located on each level of a residence.
- Maintenance: A maintenance agreement should be arranged through the local manufacturer's representative and maintenance should be performed annually by authorized personnel only. To keep a fire alarm system in excellent working order, ongoing maintenance is required per the manufacturer's recommendations and UL and NFPA standards. At a minimum the requirements of Chapter 7 of NFPA 72 (1999) shall be followed.
- Test Weekly: The alarm system should be tested weekly to make sure all sensors and transmitters are working properly. The most common cause of an alarm system not functioning when a fire occurs is inadequate maintenance.

Alarms Cannot Guarantee Warning or Protection: Fire alarm system cannot guarantee warning or protection against fire in every potential situation. A study by the Federal Emergency Management Agency (an agency of the United States government) indicated that smoke detectors may not go off or give early warning in as many as 35% of all fires.

Limitation on Fire Alarm Effectiveness: A fire alarm system may not provide timely or adequate warning, or simply may not function, for a variety of reasons. For example:

- No Detection: Particles of combustion or smoke from a developing fire may not reach the sensing chambers of smoke detectors because:
  1. **Barriers** (such as closed or partially closed doors, walls, or chimneys) may inhibit particle or smoke flow.
  2. Smoke particles may become **cold, stratify, or not reach** the ceiling or upper walls where detectors are located.
  3. Smoke particles may be **blown away** from detectors by air outlets.
  4. Smoke particles may be **drawn into air returns** before reaching the detector.
- No Multi-Floor Detection: In general, smoke detectors on one level of a structure cannot be expected to sense fires developing on another level.
- Insufficient Smoke: The amount of smoke present may be insufficient to alarm smoke detectors. Smoke detectors are designed to alarm, at various levels of smoke density. If such density levels are not created by a developing fire at the location of the detector, the detector will not go into alarm.
- Smoldering vs. Flaming Fires: Smoke detectors, even when working properly, have sensing limitations. Detectors that have photoelectric sensing chambers tend to detect smoldering fires better than flaming fires, which have little visible smoke. Detectors that have ionizing-type sensing chambers tend to detect fast flaming fires better than smoldering fires. Because fires develop in different ways and are often unpredictable in their growth, neither type of detector is necessarily best and a given type of detector may not provide adequate warning of a fire.
- False Alarms and Pre-Fire Disconnection: Smoke detectors are subject to false alarms and nuisance alarms and may have been disconnected by users. For example, a smoke detector located in or near a kitchen may go into nuisance alarm during normal operation of kitchen appliances. In addition, dusty or steamy environments may cause a smoke detector to falsely alarm. If the location of a smoke detector causes an abundance of false alarms or nuisance alarms, do not disconnect the smoke detector, call a professional to analyze the situation and recommend a solution.
- Fast Fires and Explosions: Smoke detectors cannot be expected to provide adequate warning of fires caused by arson and children playing with matches (especially within bedrooms), smoking in bed, violent explosions (caused by escaping gas, improper storage of flammable materials, etc.).
- Heat Detectors: Heat detectors do not sense particles of combustion and are designed to alarm only when heat on their sensors increases at a predetermined rate or reaches a predetermined level. Heat detectors are designed to protect property, not life.
- Unheeded Warning: Warning devices (including horns, sirens, and bells) may not alert people or wake up sleepers who are located on the other side of closed or partially open doors. A warning device that activates on a different floor or level of a dwelling or structure is less likely to awaken or alert people. Even persons who are aware may not notice the warning if the alarm is muffled by noise from a stereo, radio, air conditioner or other appliance, or by passing traffic. Audible warning devices may not alert the hearing impaired (strobes or other devices

should be provided to warn these people). Any warning device may fail to alert people with a disability, deep sleepers, people who have recently used alcohol or drugs, or people on medication or sleeping pills.

- Strobes: Strobes can under certain circumstances, cause seizures in people with conditions such as epilepsy.
  - Drills: Studies have shown that certain people, even when they hear a fire alarm signal, do not respond or comprehend the meaning of the signal. It is the property owner's responsibility to conduct fire drills and other training exercises to make people aware of fire alarm signals and instruct on the proper reaction to alarm signals.
  - Hearing Loss: In rare instances, the sounding of a warning device can cause temporary or permanent hearing loss.
- 
- Telephone Transmissions Problems: Telephone lines needed to transmit alarm signals from a premises to a central station may be out of service or temporarily out of service. For added protection against telephone line failure, backup radio transmission systems are recommended.
  - System Failure With Age or Lack of Maintenance: System components, though designed to last many years, can fail at any time. As a precautionary measure, it is recommended that smoke detectors be checked, maintained, and replaced per manufacturer's recommendations.
  - Electrical Power Problems: System components will not work without electrical power. If system batteries are not serviced or replaced regularly, they may not provide battery backup when AC power fails.
  - High Air Velocity or Dusty or Dirty Environments: Environments with high air velocity or that are dusty or dirty require more frequent maintenance.

Importance of Maintenance: In general, fire alarm systems and devices will not work without power and will not function properly unless they are maintained and tested regularly.

Alarm is Not Substitute for Insurance: While installing a fire alarm system may make the owner eligible for a lower insurance rate, an alarm system is not a substitute for insurance. Property owners should continue to act prudently in protecting the premises and the people in their premises and should properly insure life and property and buy sufficient amounts of liability insurance to meet their needs.

## **1.4 Agency Listings, Approvals, Requirements**

---

### **1.4.1 Federal Communications Commission (FCC)**

The FireNET Plus has been verified to comply with FCC Rules Part 15, Class A Operation is subject to the following conditions:

1. This device may not cause radio interference.
2. This device must accept any interference received, including any that may cause undesired operation.

### **1.4.2 Underwriters Laboratories (UL)**

The FireNET Plus is UL864 9<sup>th</sup> Edition listed and is suitable for use as a commercial protected premises control unit as follows:

- Local signaling unit
- Types of signaling services are automatic, manual, waterflow, & sprinkler supervisory.
- Style 4, 6, or 7 for Signaling Line Circuits
- Style Y for Notification Appliance Circuits
- Non-coded signaling
- Auxiliary
- Proprietary
- Central Station Service – DACT type (protected premise)
- Remote Station Service – DACT type (protected premise)
- Releasing Service when used with the XT+ Releasing Modules
- This product when used with XT+ Releasing modules satisfies releasing operation under:
  - Carbon dioxide extinguishing systems, NFPA 12
  - Halon 1301 fire extinguishing systems, NFPA 12A
  - Sprinkler systems, NFPA 13
  - Water spray fixed systems for fire protection, NFPA 15
  - Foam-water sprinkler and foam-water spray systems, NFPA 16
  - Dry chemical extinguishing systems, NFPA 17
  - Wet chemical extinguishing systems, NFPA 17A
  - Water mist, NFPA 750
  - Clean agent fire extinguishing systems, NFPA 2001
  - Fixed Aerosol fire extinguishing systems, NFPA 2010

### **1.4.3 National Fire Protection Association (NFPA)**

Install and configure the FireNET system in accordance with NFPA 72 and 13.

All field wiring must be installed in accordance with NFPA 70 National Electric Code (Article 760).

## Section 2 – Control Panel Installation

---

### ***2.1 What's in the Box?***

---

The FireNET Plus control panel includes the following components and hardware:

- ❑ Control panel cabinet with hinged door.
- ❑ Control panel annunciator, power supply, SLC loop and associated electronics are contained on one circuit board which is pre-mounted in the cabinet.
- ❑ Built-in RS232 interface
- ❑ Two keys for the cabinet lock and two keys for the Enable Controls keyswitch.
- ❑ (2) Zero ohm jumpers PN# S2026, and (2) EOLD devices PN# S2030.
- ❑ Battery jumper for series connection of two 12 volt batteries.
- ❑ Installation Manual (PN# 1700-10840)

### ***2.2 Environmental Specifications***

---

The FireNET Plus control panel should be installed in locations where it will NOT be exposed to temperatures outside the range of 32° F – 120°F or humidity outside the range of 10% - 85% non-condensing.

The FireNET Plus control panel must be installed so that it is not subjected to damage by water and condensation. AVOID mounting the control panel cabinet directly on exterior masonry walls, in areas subject to plumbing leaks, in areas subject to splash from sprinkler test valves, or in high humidity areas.

The FireNET Plus control panel is intended for installation in indoor environments in a dry location.

## 2.3 Control Panel Layout

### 2.3.1 Front Panel Controls and Display

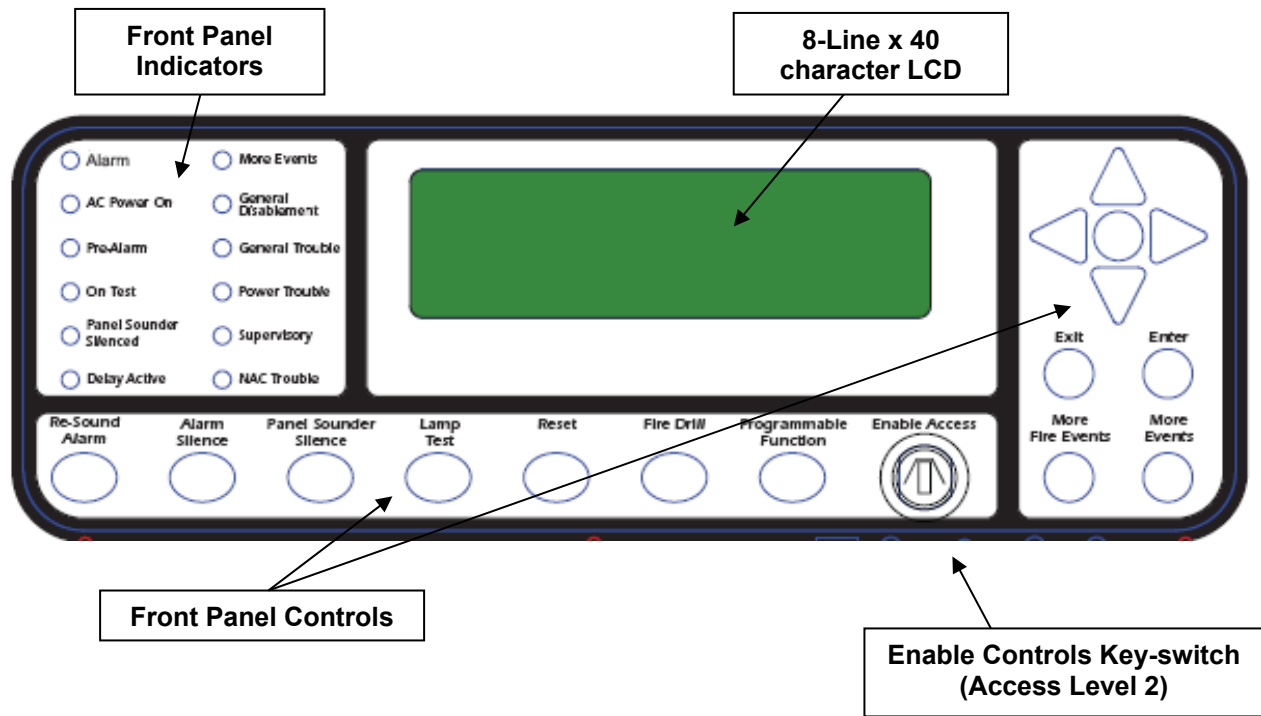

Figure 2.3.1 – Controls and Display

## 2.3.2 Enclosure and Panel Layout

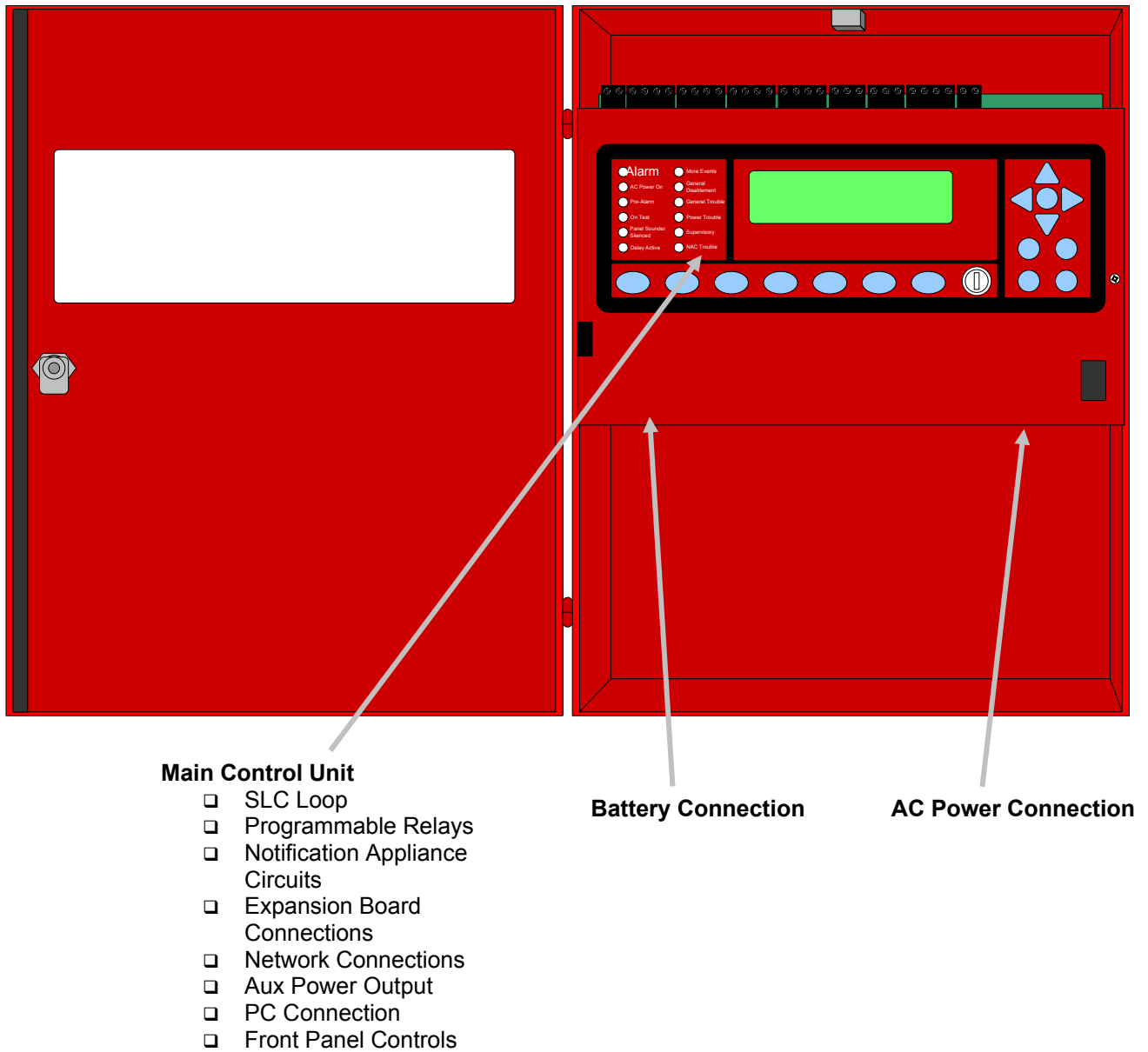

Figure 2.3.1 – Enclosure and Panel Layout



## **2.4 Mounting the Control Panel**

---

Consult the environmental specifications listed in Section 2.2 to determine a suitable location to mount the FireNET Plus main control panel.

The panel should be mounted so that it is accessible to service personnel and located in a secure area.

Do not mount directly to a concrete wall. Use a suitable standoff material such as plywood to keep condensation away from the control panel.

## **2.5 Wiring Specifications**

---

Care should be taken when wiring the system to avoid situations that would contribute to inducing electrical noise from one wire to another. Induced noise can interfere with telephone communications or cause erratic system operation. Follow these guidelines to plan your system wiring prior to installation.

- Route high and low voltage wiring separately. Maintain a minimum 2” separation between high and low voltage wiring throughout the building.
- Route control panel wiring around the perimeter of the enclosure. A minimum .25” separation is required between high and low voltage wiring.
- Identify which group each wire or cable is associated with from the list below. Isolate each groups wiring as much as possible. Avoid running a single multi-conductor cable for multiple groups of conductors.
  - AC Power - Main Power Supply
  - Notification Appliances
  - SLC Circuits
  - Relay Outputs
  - Voltage Outputs
  - Remote Control and Auxiliary Inputs
  - Network Wiring (Shielded wire required)
  - RS485 Bus Wiring (Shielded wire required)
- Keep wiring from different groups separated as much as possible. If you must share the same conduit with different conductor groups consider using shielded cable.
- If shielded cable is used terminate the shield to the earth ground terminal block in the main control panel and leave open at field side of cable. Do not ground at both ends of cable.
- All terminals on the FireNET control can accept wire gauges from 22AWG and 12AWG.

## 2.5.1 Suggested Routing of AC Power

Route the AC input power wiring as outlined below. Follow recommendations outlined in section 2.5 regarding the separation of high and low voltage wiring.

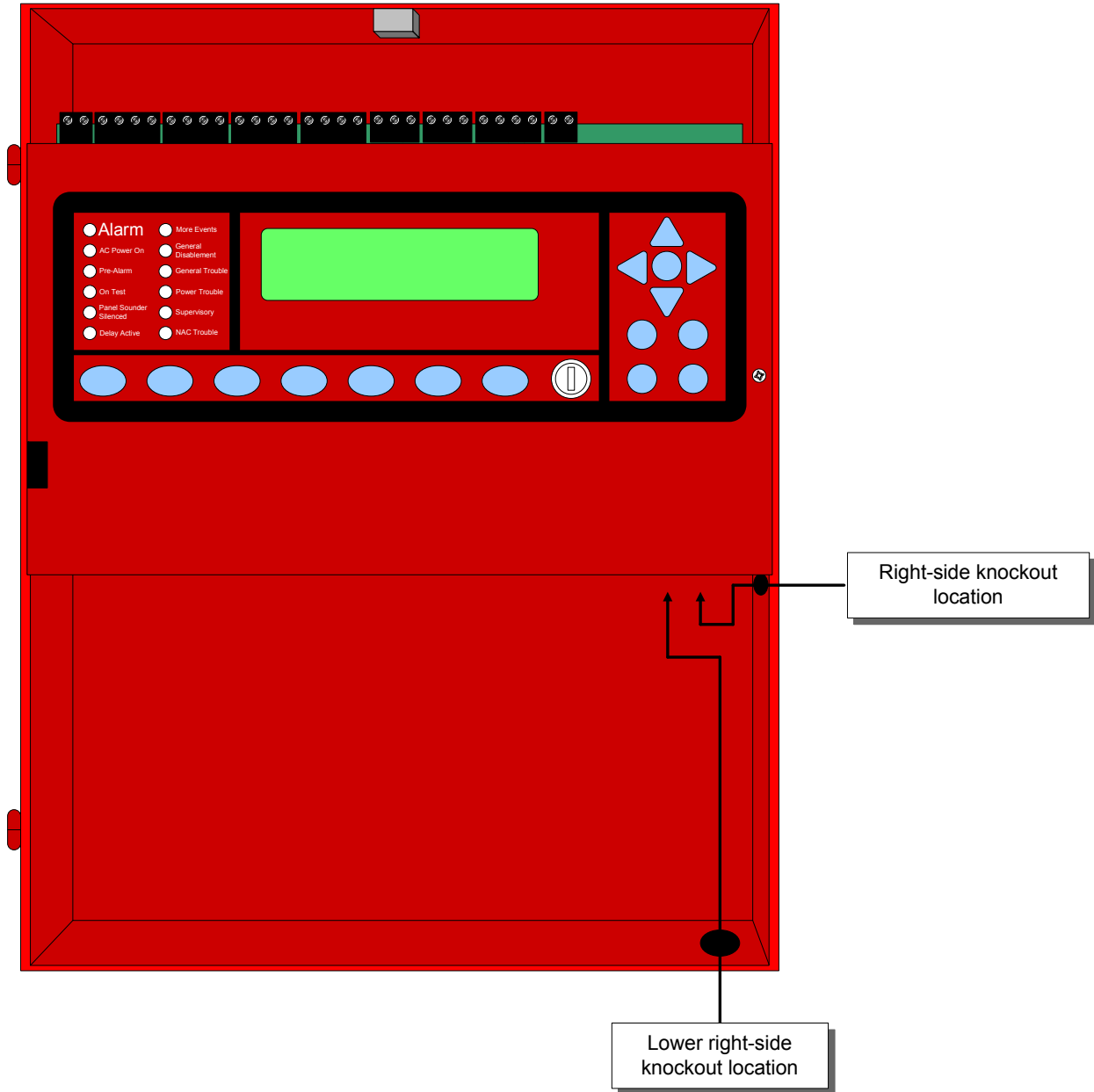

**Figure 2.5.1 – Suggested Routing of AC Power**

The preferred entry location for AC input power is via the right side knock-out (see illustration above). DO NOT route AC input power across the main control board or directly across or adjacent to the low-voltage connections made on the top terminal strip!

## 2.6 Battery Calculations

### FireNET Plus Battery Calculator Tool

The FireNET Plus Battery Calculator Tool will help you determine the batteries needed for your installation. In order to use this tool you must know the number and type of devices that will be attached to your control panel, and the current requirements of any auxiliary devices being powered by the control panel. The blue boxes are the standby and alarm subtotals; these are added together when the form is completed to determine the minimum battery size required.

How much **Standby Time** (in hours) is required for the installation?  Hours  
 How much **Alarm Time\*** (in minutes) is required for the installation?  Minutes

FireNET Plus Panel Hardware	SLC 1	SLC 2	Panel Totals	Panel Standby Current	Total Standby Current
FNP-1127 1-Loop Panel	1		1	0.20000	
FNP-1127-SLC Loop Expander				0.07500	
FN4127-NIC Network Card				0.06000	
Integrated DACT Option				0.02500	
SLC Device Communication Current				0.00675	
5 Device Alarm LEDs				0.00000	0.00000
					S1 <input type="text"/>

Panel Alarm Current	Total Alarm Current
0.25000	
0.07500	
0.06000	
0.02500	
0.00675	
0.04000	
A1 <input type="text"/>	

SLC Devices	SLC 1 Devices	SLC 2 Devices	Device Total	Device Standby Current	SLC Standby Current
ALG-V Analog Photo Smoke				0.00039	
ALK-V Analog Photo Smoke				0.00039	
ALN-V Analog Photo Smoke				0.00045	
ACA-V Analog Multi-Sensor				0.00045	
ACC-V Analog Multi-Sensor				0.00045	
AIE-EA Analog Ion Smoke				0.00035	
ATG-EA Analog Heat Sensor				0.00035	
ATJ-EA Analog Fixed & RoR Heat Sensor				0.00035	
Quantity of SLC-Powered Alarm LEDs				0.00000	0.00000
ASB Analog Sounder Base				0.00011	
DH98-A Analog Duct Detector				0.00039	
DH98-AR Analog Duct Detector w/Relay				0.00039	
DH-99-A Analog Duct Detector				0.00039	
DH-99-AR Analog Duct Detector w/Relay				0.00039	
FRCME-4, P Input Module				0.00055	
FRCMA Class A Input Module				0.00063	
FRCMA-I Class A Input Module + SCI				0.00063	
FRCME-M Input Module				0.00034	
DIMM Dual Input Monitor Module				0.00060	
AMS Addressable Pull Station				0.00055	
CZM Conventional Zone Module				0.00068	
SOM Supervised Output Module				0.00015	
SOM-A Class A Output Module				0.00042	
SOM-AI Class A Output Module + SCI				0.00042	
SOM-R Supervised Output Module				0.00015	
R2M Dual Relay Module				0.00039	
R2ML / R2MH Dual Relay Module				0.00035	
R2ML-I, R2MH-I Dual Relay Module + SCI				0.00035	
SCI Short Circuit Isolator				0.00027	
SCI-B6 / SCI-B4 Short Circuit Isolator Base				0.00016	
<b>Totals</b>					S2 <input type="text"/>

Device Alarm Current	SLC Alarm Current
0.00054	
0.00080	
0.00054	
0.00054	
0.00054	
0.00046	
0.00050	
0.00050	
0.00800	
0.00011	
0.00054	
0.00054	
0.00054	
0.00066	
0.00630	
0.00630	
0.00036	
0.00072	
0.00066	
0.00072	
0.00016	
0.00050	
0.00016	
0.00040	
0.00041	
0.00041	
0.00027	
0.00016	
A2 <input type="text"/>	

Notification Appliance Circuits	NAC 1	NAC 2
NAC Appliance Current per Circuit		
Standby Aux Power from SLC above		
Alarm Aux Power from SLC above		
Standby Aux Power from page 2		
Alarm Aux Power from page 2		
<b>Total NAC standby current</b>		
<b>Total NAC alarm current</b>		

NAC  
STANDBY  
TOTAL  
S3

NAC ALARM  
TOTAL  
A3

Continue calculation on Page 2.

Revision 1.18m

# FireNET Plus Battery Calculator Tool (page 2)

Auxiliary Power Circuit	24V OUT	Aux 24V
Other Auxiliary Power Current		
Standby Aux Power from SLC above		
Alarm Aux Power from SLC above		
Standby Aux Power from page 2		
Alarm Aux Power from page 2		
Total Aux Power standby current		
Total Aux Power alarm current		

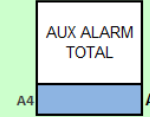
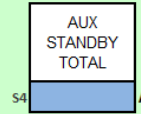

Do not exceed the capability of the NACs and Aux Power circuits! See the FireNET Plus Manual for details.

The amount of current needed to power Auxiliary Devices varies with each application. Large amounts of current may be necessary. Enter all devices powered by the FireNET Plus panel, including I/O boards, annunciators, SOMs and other SLC devices, and additional equipment such as beam detectors.

Auxiliary Power Devices	Device Quantity	Standby Current	Alarm Current
Total Standby and Alarm Current for all SOMs			
FN-LCD-N Network Annunciator		0.150	0.270
FN-LCD-S Serial Annunciator		0.020	0.110

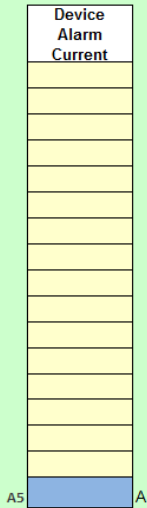
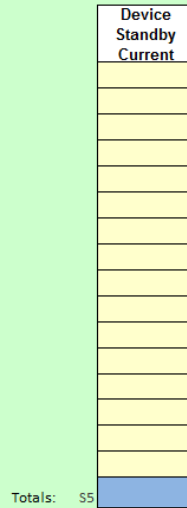

Up to 32 I/O Boards can be connected to a single FireNET Plus control panel. Note: Each I/O Board has 2 banks of 8 I/O channels. The maximum current output per channel is 0.100A with a total of 0.500A per bank.

Total Standby Current Draw (add S1 - S5) =	AMPS
x Standby Time	Hours
Standby Amp-Hours Required =	AH
Total Alarm Current Draw (add A1 - A5) =	AMPS
x Alarm Time	Hours*
Alarm Amp-Hours Required =	AH
Total AH Required =	AH
x Derating Factor	(20%)
<b>Minimum Battery Size:</b>	<b>AH</b>
(The FireNET Plus panel can support batteries up to 60 AH. )	
* Alarm Time: 0.083=5min, 0.167=10min, 0.250=15min, 0.333=20min, 0.500=30min.	

Site Information

Site Name: \_\_\_\_\_  
Address: \_\_\_\_\_  
City: \_\_\_\_\_  
State & ZIP: \_\_\_\_\_  
Phone: \_\_\_\_\_  
Panel Info: \_\_\_\_\_  
Install Date: \_\_\_\_\_  
Misc.: \_\_\_\_\_

NOTE: Hochiki hereby disclaims all warranties relating to this software product, whether expressed or implied. Including without limitations any implied warranties of merchantability or fitness for a particular purpose. Hochiki cannot and will not be liable for any incidental, consequential, special, indirect or similar damages for any reason. It is the responsibility of the user to ascertain the accuracy and the reliability of any and all information generated or provided by this software.

Revision 1.18m

## 2.7 Electrical Ratings

Terminal Label			Description	Rating	
				Voltage	Current
E	Ground		Ground Connection	0VDC	-
E	Ground		Ground Connection	0VDC	-
L1T	Phone Line 1		Incoming phone line connection from telephone company (FNP-1127D/DE only)	48VDC	30mA
L1R				48VDC	30mA
P1T			Outgoing phone line connection to telephone sets (FNP-1127D/DE only)	48VDC	30mA
P1R				48VDC	30mA
L2T	Phone Line 2		Incoming phone line connection from telephone company (FNP-1127D/DE only)	48VDC	30mA
L2R				48VDC	30mA
P2T			Outgoing phone line connection to telephone sets (FNP-1127D/DE only)	48VDC	30mA
P2R				48VDC	30mA
+ 24V	24V Out		Auxiliary 24V Power	24VDC	360mA
- 24V				24VDC	360mA
+ 24V	Aux 24V		Auxiliary 24V Power	24VDC	360mA
- 24V				24VDC	360mA
+	NAC 1		Notification Appliance Circuit #1. EOLD Required. <i>Note: 24VDC Regulated @ 1.6A Continuous 24VDC Regulated @ 900mA Pulsing 24VDC @ 2.3A Special Application</i>	24VDC	2.3 A
-				24VDC	2.3 A
+	NAC 2		Notification Appliance Circuit #2. EOLD Required. <i>Note: 24VDC Regulated @ 1.6A Continuous 24VDC Regulated @ 900mA Pulsing 24VDC @ 2.3A Special Application</i>	24VDC	2.3 A
-				24VDC	2.3 A
+ IN	SLC 1		Signaling Line Circuit. OUT terminals used for Class B or A wiring.	32VDC	250mA
- IN				32VDC	250mA
+ OUT			Signaling Line Circuit. IN terminals used for return loop for Class A wiring.	32VDC	250mA
- OUT				32VDC	250mA
NC	Trouble		Trouble relay	30VDC	1 A
C				30VDC	1 A
NO				30VDC	1 A
NC	Fire		Fire Alarm relay	30VDC	1 A
C				30VDC	1 A
NO				30VDC	1 A
NC	Supervisory		Supervisory relay	30VDC	1 A
C				30VDC	1 A
NO				30VDC	1 A
+	NET Out		RS485 Network OUT to other panels	12VDC	100mA
-				12VDC	100mA
+	NET In		RS485 Network IN from other panels	12VDC	100mA
-				12VDC	100mA
+	COMMS Bus		RS485 to I/O boards and serial annunciators	12VDC	100mA
-				12VDC	100mA
+ OUT	SLC 2		Signaling Line Circuit. OUT terminals used for Class B or A wiring.	32VDC	250mA
- OUT				32VDC	250mA
+ IN			Signaling Line Circuit. IN terminals used for return loop for Class A wiring.	32VDC	250mA
- IN				32VDC	250mA

Table 2.7.1 Terminal Strip Electrical Ratings

### Table 2.7.3 Power Supply Connections

The AC and Battery connectors are located at the bottom of the main control board. These connectors may be removed (unplugged) for ease of installation.

Connector	Terminal	Description	Rating	
			Voltage	Current
TB6	G	Earth Ground	N/A	N/A
	N	AC Neutral	120 VAC, 50/60Hz	2.1A
			240 VAC, 50/60Hz	1.1A
	L	AC Line	120 VAC, 50/60Hz	2.1A
			240 VAC, 50/60Hz	1.1A
TB3		+ Battery	+24 VDC	5A
		- Battery	DC Common	5A

Table 2.7.2 Power Supply Terminal Strip Electrical Ratings

**NOTE:** Earth ground fault detection impedance is approximately 100K ohms between earth ground and the FireNET Plus internal floating DC supply.

## 2.8 Specifications

---

Primary AC:	120VAC @ 2.1 amps 50/60hz (or) 240VAC @ 1.1 amp 50/60hz
Output DC:	24VDC @ 4 amps
Power Supply:	5.25 amp integrated
Max Charger Current:	1.25 amps
Dimensions:	14.5"W x 19" H x 3.5"D
Weight:	20 lbs (without batteries)
Color:	Red (optional charcoal)
Material:	ABS/steel enclosure
Display:	8 line x 40 character LCD (320 characters total)
Network:	Dual RS485 ports (64 panels max.)
Zones:	500 network wide software zones per system (Output zones allocated to zones 1 to 253 only for SOM 2.0 and earlier)
SLC loops:	1 or 2 (class A or B)
Devices per Loop:	127 sensors & modules, plus 127 analog sounder bases, 254 total
Addresses per Panel	(800 addresses + sub-addresses max per panel)
NAC Outputs**:	(2) 2.3 A @ 24VDC Special Application 1.6 A @ 24VDC (Continuous) Regulated 900mA @ 24VDC (Pulsing) Regulated
Relay Outputs:	(3) Form C contact 1amp@30VDC
Aux. Power:	360mA@24VDC
PC Port:	RS232
DACT Formats (FNP-1127D / DE only)	Contact ID and SIA
Firmware Revision	07.xxxx

**\*\*Note:** Combined maximum for both NAC outputs must not exceed 3.1A under Special Application.  
Combined maximum for both NAC outputs must not exceed 3.2A under (Continuous) Regulated.  
Combined maximum for both NAC outputs must not exceed 1.8A under (Pulsing) Regulated.

## Section 3 - Power Supply and Main Control Unit Connections

---

### 3.1 AC Power Connection

---

The AC power connection terminal block is located in the lower right hand corner of the control board (when viewed from the front, see Figure 3.1). Observe the wiring polarity and connect as shown. Local electrical codes may require that a licensed electrician make these connections.

NFPA 72 requires that the AC connection be made from a dedicated branch circuit that is mechanically protected. The circuit must be marked in red and identified as a “FIRE ALARM CIRCUIT”. The location of the circuit and its disconnecting means shall be permanently noted at the fire alarm control panel. The circuit breaker must be rated at 20 amps maximum.

**Fuse Replacement:** To replace the power supply fuse F7, power down the fire system by removing the AC power first, then disconnect the backup batteries to the fire alarm control panel. Remove the blown fuse and replace with a 3A 250VAC, slow blow, 5X20mm fuse. When the fuse replacement is completed, restore AC power to the control panel and connect the backup batteries observing polarity of connections.

### 3.2 Battery Connection

---

The FireNET Plus fire alarm control panel can charge up to 60AH batteries maximum. Use the current draw and battery calculation worksheet in section 2.6 to determine the correct battery size to use.

The battery leads connect to the battery terminal block located at the lower left-hand corner of the control board (when viewed from the front). Connect two 12-volt batteries in series to the battery leads as shown in Figure 3.1. Both batteries must be of the same AH rating. Do not try to parallel multiple batteries together to obtain a higher AH rating. Use only UL Recognized Sealed Lead Acid Batteries.

**Fuse Replacement:** To replace the in-line battery fuse, remove the battery lead (BLACK) from the negative battery terminal and twist the bayonet fuse holder to open. Remove the blown fuse and replace with a “Bussman AGC-10” (10A) type fuse or equivalent. Reassemble the bayonet fuse holder and attach the battery lead to the negative terminal of the battery.

**NOTE:** The standby batteries cannot power the system until the main 120VAC power has been established. Once the system has been initially powered from them 120VAC source the batteries will operate the system in the event of a power failure.



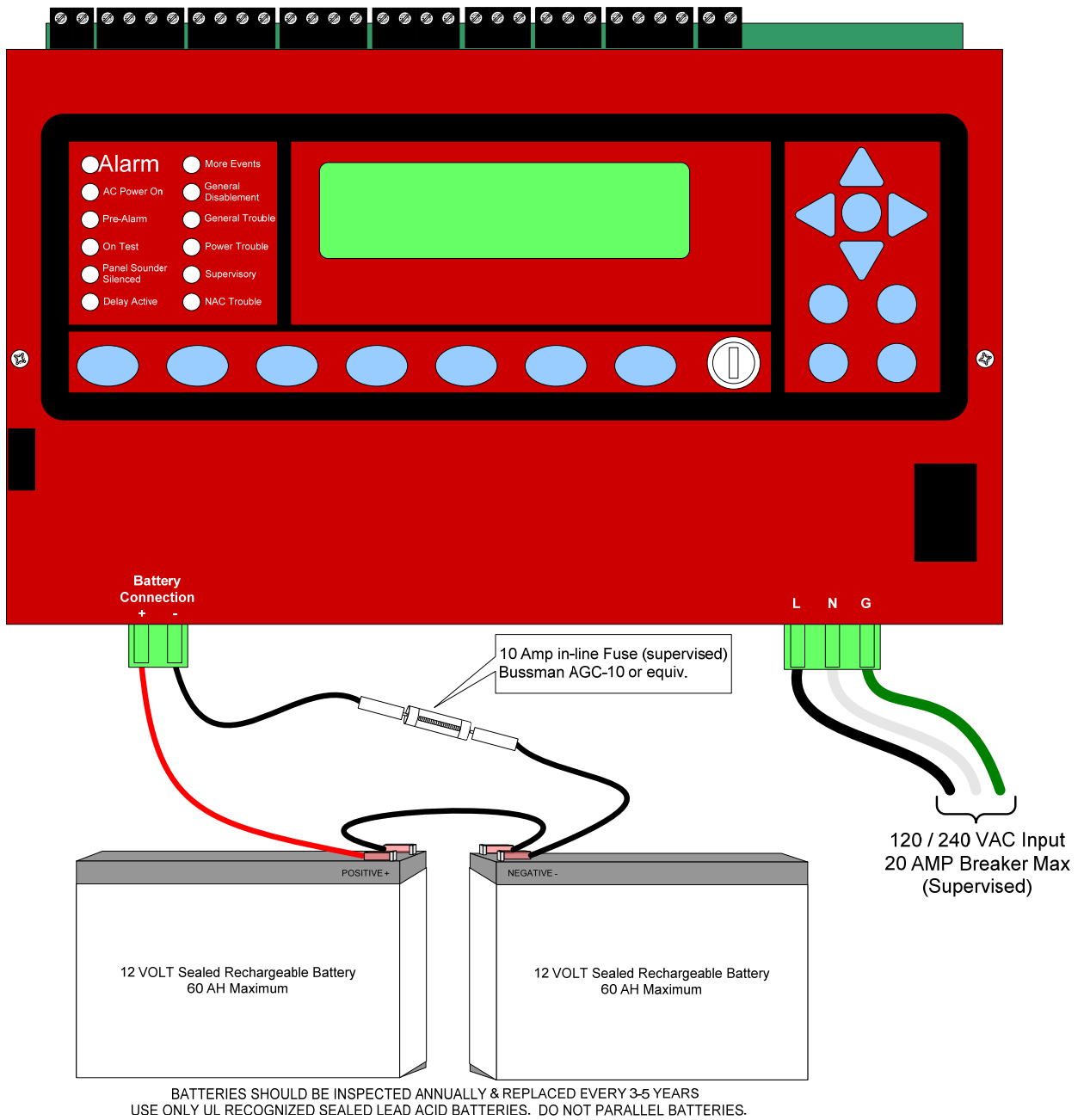

**Figure 3.1 Power Supply Connection Detail**

### 3.3 Auxiliary Power Connection

---

24 VDC auxiliary powers are available on the main control board for powering remote annunciators, I/O modules and other low-current powered devices.

The total output from each Auxiliary Power output must not exceed .360 amps.

All devices powered from the auxiliary power terminals should be entered into Table 2.6 and taken into consideration for standby battery size.

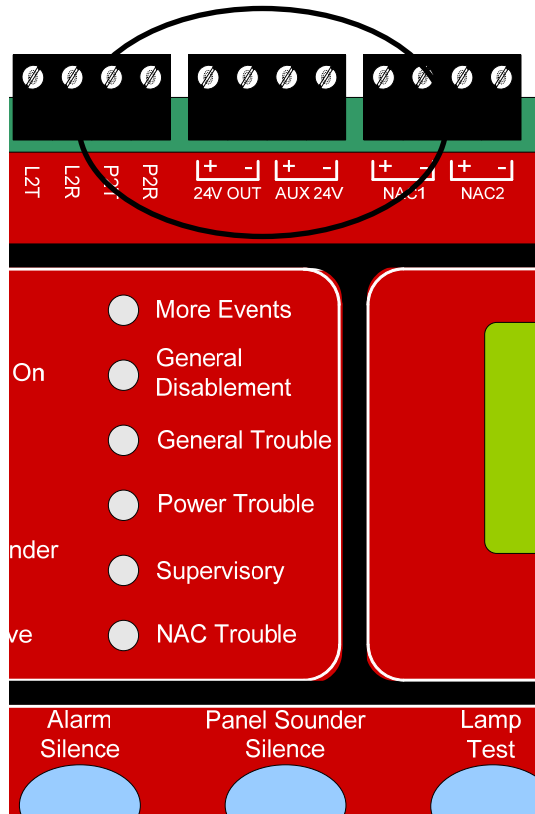

Figure 3.2 Auxiliary Power Connection Detail

### 3.4 Notification Appliance Circuit Connection

- NAC outputs rated @ 2.3 amps each (Special Application)  
(EOL P/N: S2030 or P/N: S2028 can be used)
- NAC outputs rated @ 1.6 amps each (Continuous) Regulated.  
(Hochiki America EOL P/N: P/N: S2030 or P/N: S2028 can be used)
- NAC outputs rated @ 0.9 amps (Pulsing or Gentex) Regulated.  
(EOL P/N: S2030 or P/N: S2028 can be used)
- See Appendix A.3 for compatible NAC Devices.
- See Section 8 of this manual for programming.

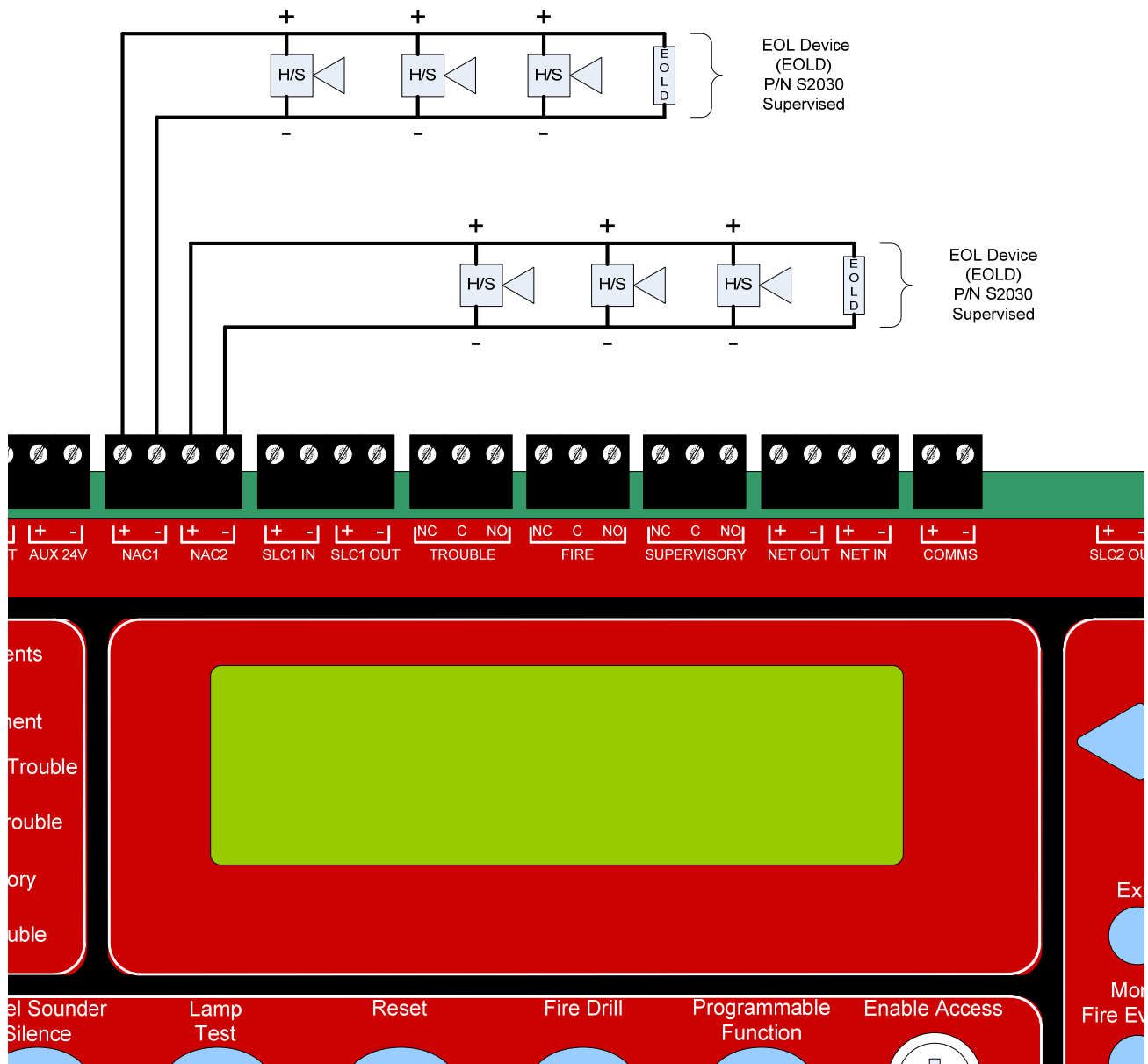

Figure 3.3 Notification Appliance Circuit Connection Detail

### 3.5 Relay Output Connection

---

- Relays are dry Form “C” contacts and are fully programmable.
- See section 8 of this manual for programming.

Conventional Relay Contacts rated for 1A @ 30 VDC.  
Must be connected to a power limited source.  
(Not Supervised) (Resistive)

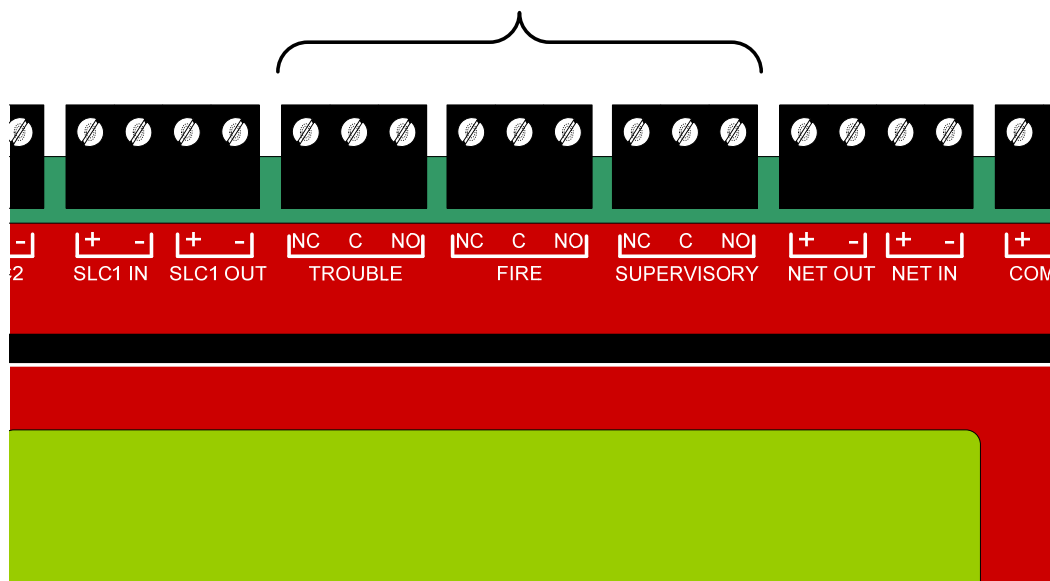

Figure 3.4 Relay Outputs Detail

### 3.6 Phone Line Connections (FNP-1127D and FNP-1127DE only)

The FireNET Plus contains an integrated DACT (Digital Alarm Communicator Transmitter) with connections for two telephone lines.

- Phone line connections are supervised.
- To comply with NFPA standards, Ground Start telephone lines must not be used.
- See Section 7.6 for DACT operation and event reporting codes.
- A panel which is connected to EMS Graphix system must have the PC / Dialer switch in the PC position, and no dialer may be used on this panel. A dialer may be used by another node in the network.

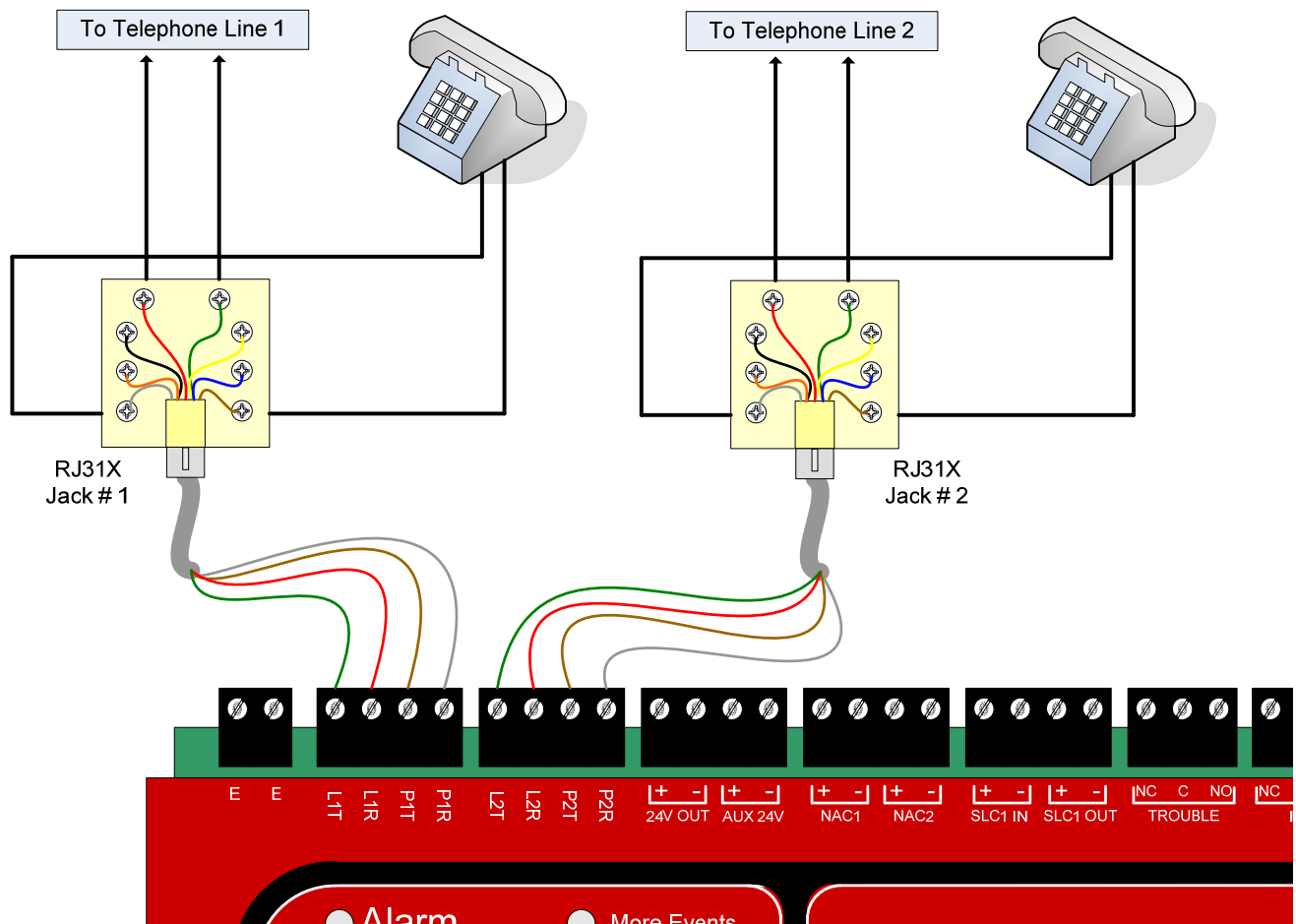

Figure 3.5 – Telephone Line Connections to the FireNET Plus

The DACT must be connected upstream of any private telephone systems at the protected premise. See figure 3.5 above.

**NOTE:** To ensure proper connection to the public switched telephone network, UL Listed RJ31X jacks and cords must be installed.

**NOTE:** Two separate telephone lines are required. Do not connect both telephone interfaces on the FireNET Plus to the same telephone line.

**NOTE:** The maximum distance between the FireNET Plus and the RJ31X jacks must not exceed 6 feet. Do not use a phone cord that is longer than 6 feet in length.

## Section 4 – Expander Board Installation

---

### 4.1 Compatible Expander Boards

---

The following Hochiki America Corp. expander boards are listed as compatible with the FireNET Plus analog addressable fire alarm system.

#### Expanders

- FNP-1127-SLC - SLC Loop Expander (Local FACP Expander)
- FN-4127-IO – 16 Channel Input/Output Board (RS-485 Bus Device)
- FN-LCD-S Serial LCD Annunciator (RS-485 Bus Device)
- XT+ – Releasing Module(s) –see *Man-1252HA* for complete product and installation information

This section covers the installation of the devices listed above. For proper operation each of these devices must be programmed. Please refer to Section 8 of this manual for more information on programming the functionality of expander boards.

### 4.2 General Installation of RS-485 Bus Devices

---

#### 4.2.1 Wiring Distance and Mounting Locations

RS485 bus devices can be mounted either in the main control panel enclosure or in an accessory cabinet (FN-ACC). When mounting remotely in an accessory cabinet the distance from the panel to the RS485 bus device must not exceed 4000 feet. A suitable communications cable for RS485 applications must be used for the RS485 bus devices.

Specific wiring connections for each device are included later in this section. For specific wiring distance, connections, and mounting of the FN-LCD-S serial LCD Annunciator, see Section 4.7.

## 4.2.2 Addressing

Up to 32 RS485 bus devices can be added to the system. Each RS485 bus device must be set to a unique address 1-32.

The address for each RS485 bus device is set using a position DIP-switch in binary fashion. Switches 1-5 represent the values 1, 2, 4, 8, 16, and 32 respectively. To set the address, move only the switches whose values when added equal the address value you wish to set to the “ON” position. For example, moving switches 1 and 3 (whose values are 1 and 4 respectively) to the “ON” position sets the address of 5 into the RS485 bus device. See the other examples below:

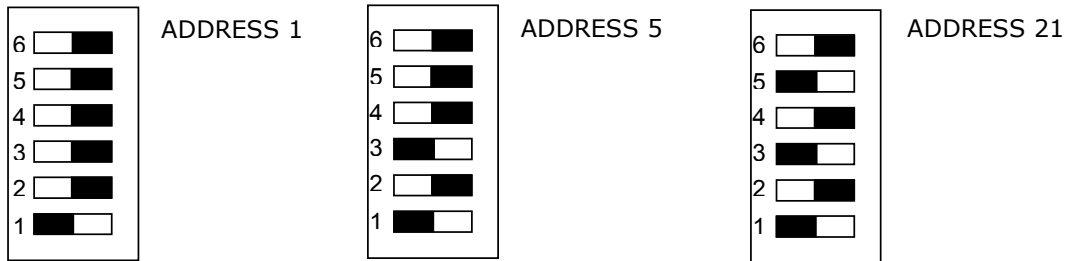

Shows switch actuator in the ON position.

Switch Number	Value
1	1
2	2
3	4
4	8
5	16
6	32

Addresses must be set with no power applied to the system.

## 4.2.3 Terminating

The last board connected to the RS485 bus must have a terminating jumper installed at position J3 as shown in figure 4.2.3.1

Even if only 1 RS485 bus device is connected to the panel this jumper must be installed.

Jumper J3

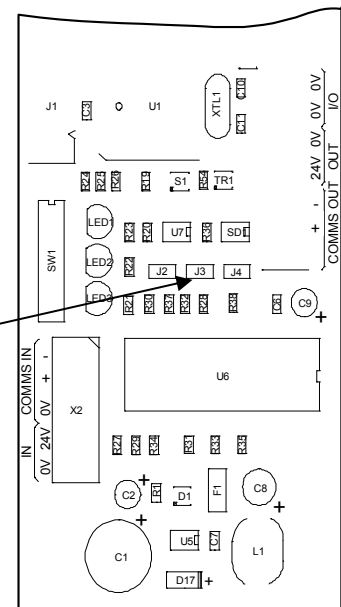

Figure 4.2.3.1

## 4.2.4 Power Connections

All RS485 bus devices require 24 VDC to operate. The AUX 24V terminals of the FireNET plus may supply this voltage (360 milliamps maximum), or you may use an external power supply that provides 24 VDC output.

Connections are provided on each RS485 bus device for both incoming and outgoing power.

## 4.2.5 COMMS Connection

In addition to power, each RS485 bus device requires a pair of conductors for data communication. This wiring is connected to the COMMS + and - terminals on the FireNET Plus control panel. If more than one RS485 device is being used, it may be connected to the COMMS OUT + and - terminals of the previous RS485 bus device.

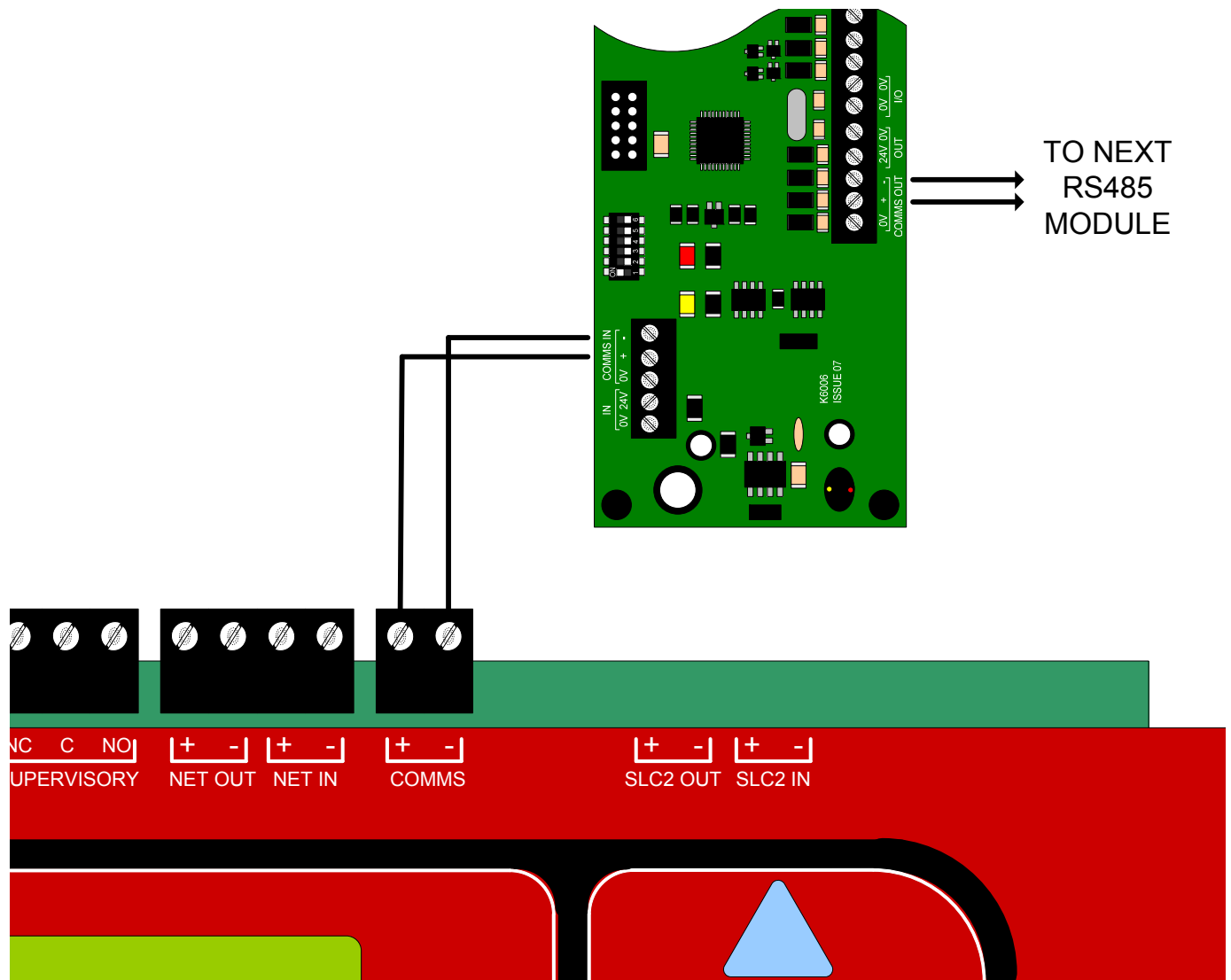



## 4.3 FN-4127-IO - Input / Output Board

In addition to the basic 254 points that the FireNET Plus can accommodate on the SLC loops, additional input and output points can be added by using FN-4127-IO Input/Output boards on the RS485 bus.

The FN-4127-IO has 16 channels. Each channel can be individually configured as either an input or an output. Up to 32 FN-4127-IO boards can be connected to the system via the RS485 bus giving the system an additional 512 inputs/outputs.

### 4.3.1 Configuring Inputs

Inputs to the FN-4127-IO are optically isolated and connected to the board by installing a normally open contact with a resistance no greater than 500 ohms to any input and a terminal marked 0V. The current switched by the contact will be a maximum of 3 milliamps.

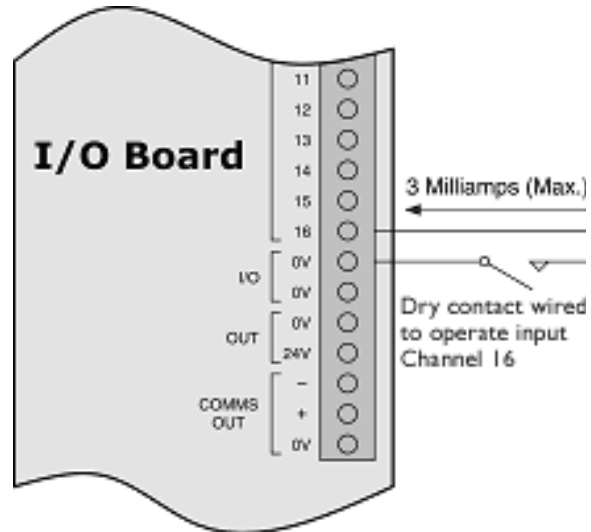

**NOTE:** Inputs on the I/O board are not supervised. These inputs are not for primary initiating or detection of fire or life safety conditions. These inputs are programmable for secondary use only, and not used for signaling Fire, Supervisory, or Trouble conditions. All primary initiating or detection inputs must be connected to applicable SLC devices listed for fire. See Section 5 of this manual for SLC devices.

### 4.3.2 Configuring Outputs

When configured as outputs, the I/O board channels supply a negative voltage (with respect to the I/O board 24V power supply) via a transistor.

Because transistor elements can be damaged by excessive current drain, great care should be taken when connecting to outputs. Particular care should be taken to ensure that suppression diodes on relay coils are correctly polarized. Wrongly connected diodes will damage the outputs. Diodes should be connected with the band to the positive 24V.

Individual channels can supply current up to 100 milliamps but this must be limited to 500 milliamps for each bank of eight (500 milliamps for 1-8 and 500 milliamps for 9-16). The power supply to the I/O board should also be considered to ensure that its rating is not exceeded if multiple channels are switched on. Overall current draw for the I/O board is 1010mA max.

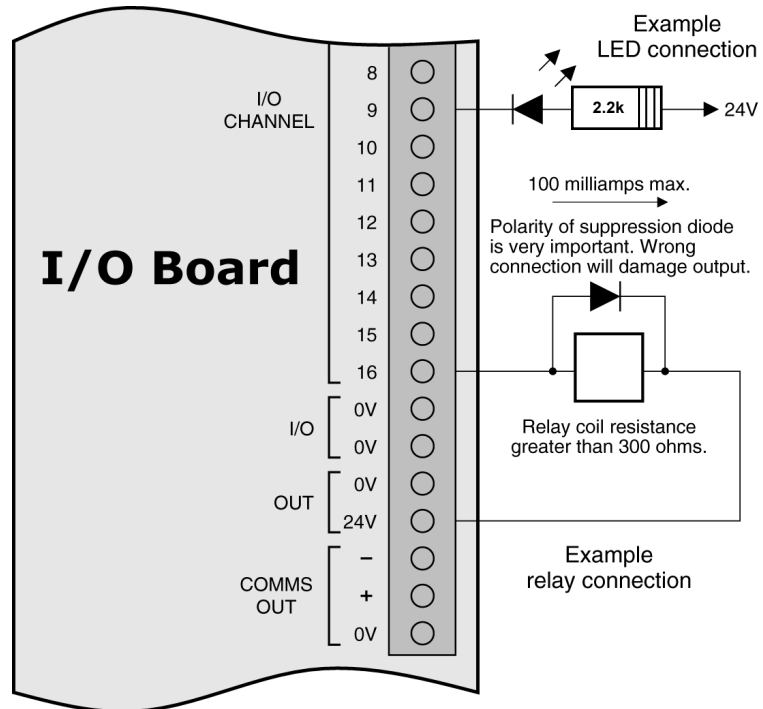

**NOTE:** Outputs on the I/O board are not supervised. These outputs are not for primary notification of fire conditions (i.e. not for use as NAC circuits). These outputs are for secondary use only. All primary notification output devices must be connected to applicable NAC circuits on the FireNET panel. See Section 3.4, Appendix A, and B for details on NAC circuits and compatible NAC devices.

When powering the I/O board from the FireNET Plus auxiliary 24VDC power (limited to 360ma), the following maximum wiring distances apply at the gauges noted:

<u>Wire</u>	<u>Distance</u>
18AWG	875ft
16AWG	1400ft
14AWG	2300ft
12AWG	3700ft

When powering the I/O board from a separate Aux 24VDC UL Fire listed supply the maximum voltage drop cannot exceed 4VDC.

### 4.3.3 LED Indicators

LED indicators on the I/O board give some simple diagnostic information and show that the boards are communicating with the control panel. The red LED (LED1) is on during receipt of a message from the control panel.

- **If the LED is flickering more or less continuously** - the board is operating normally.
- **If this LED is not lit** - the board is not receiving data from the control panel and the comms connection should be checked.
- **If this LED is permanently lit** - then it is likely that data is being received but that it is being corrupted. In this case the quality of the comms connection should be checked for interference from mains or other noise generating sources.

The yellow LED (LED2) will flicker briefly every few seconds when the I/O board responds to the main panel. If this LED does not flicker then it is not responding to the control panel and the comms connection should be checked.

LED 1

LED 2

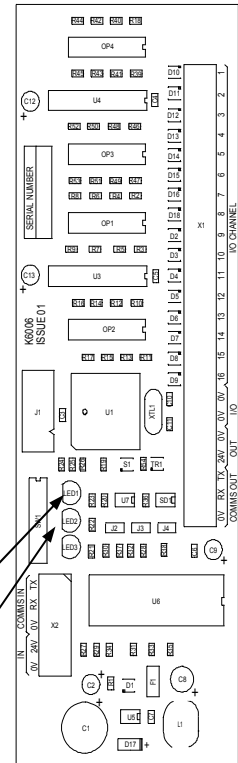

## 4.6 FNP-1127-SLC – SLC Loop Expander

---

The FireNET Plus control panel is provided with one SLC Loop; however an additional SLC Loop may be added at the factory or a later date if required through the use of a FNP-1127-SLC expander board.

The main control unit has terminations for connecting the first SLC loop. The connections for the second loop are located on the FNP-1127-SLC expander board.

### 4.6.1 Installation of the FNP-1127-SLC

1. To install the additional SLC Loop, the control panel must have its AC and battery power removed. *Do not attempt to install the SLC expander board while the FireNET Plus panel is powered!*
2. Remove the screw on the front display panel and open the panel to the left, exposing the back of the circuit board.
3. The circuit board containing the additional loop circuit is supplied in a static dissipative bag and should remain in this bag until it is to be installed.

**NOTE:** As with all electronic components, this circuit board is very sensitive and can be easily damaged by electrostatic discharge.

4. The loop board mounts on the upper left hand side of the rear of the circuit board. Install the mounting standoffs to the main board then attach the expander board using the M3 screws and fiber washers.
5. After ensuring that the new circuit board is properly installed and making good contact with its connectors, close the front display panel and secure with the screw.
6. Connect the SLC loop wiring and then re-apply power to the control panel.
7. Class B SLC circuits require the 0 ohm jumpers to be installed – please see Section 5.3.1.

After the new SLC devices have been installed and connected, they may be automatically detected using the auto learn feature from the menu on the control panel (see Section 8 of this manual).

## 4.7 FN-LCD-S Serial Liquid Crystal Display Annunciator

The FN-LCD-S Serial LCD Annunciator duplicates the indications of the FireNET Plus fire alarm control panel. The FN-LCD-S connects to the control panel via the RS485 serial bus that is designated “COMMS” on the control board. Up to 15 FN-LCD-S annunciators may be connected via the COMMS bus to a single FireNET Plus control panel.

### 4.7.1 Installation of the FN-LCD-S

Refer to section 2.2 of this manual for environmental installation specifications. The FN-LCD-S should be mounted so that it is accessible to service personnel and located in an area in compliance with local regulations.

The FN-LCD-S may be surface or flush mounted. Do not mount directly to a concrete wall. Use a suitable standoff material such as plywood to keep condensation away from the annunciator.

For operations and programming, refer to Sections 7 and 8 of this manual. The FN-LCD-S operates in the same manner as the main panel operator interface and controls.

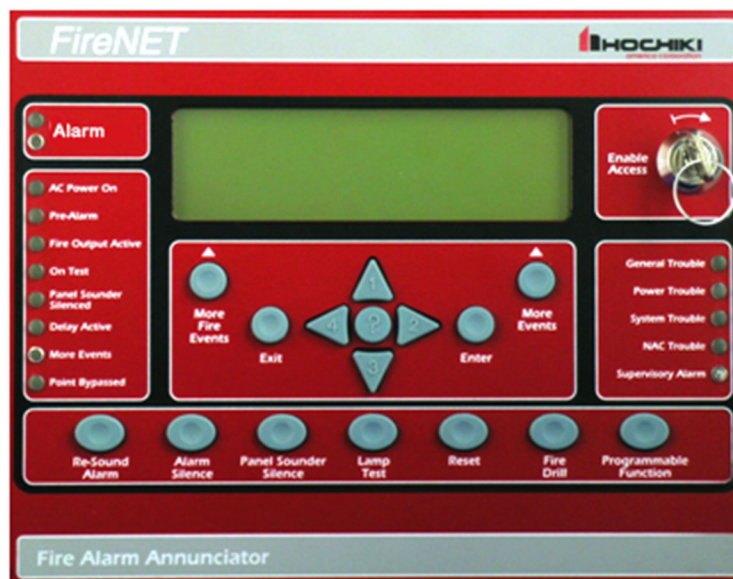
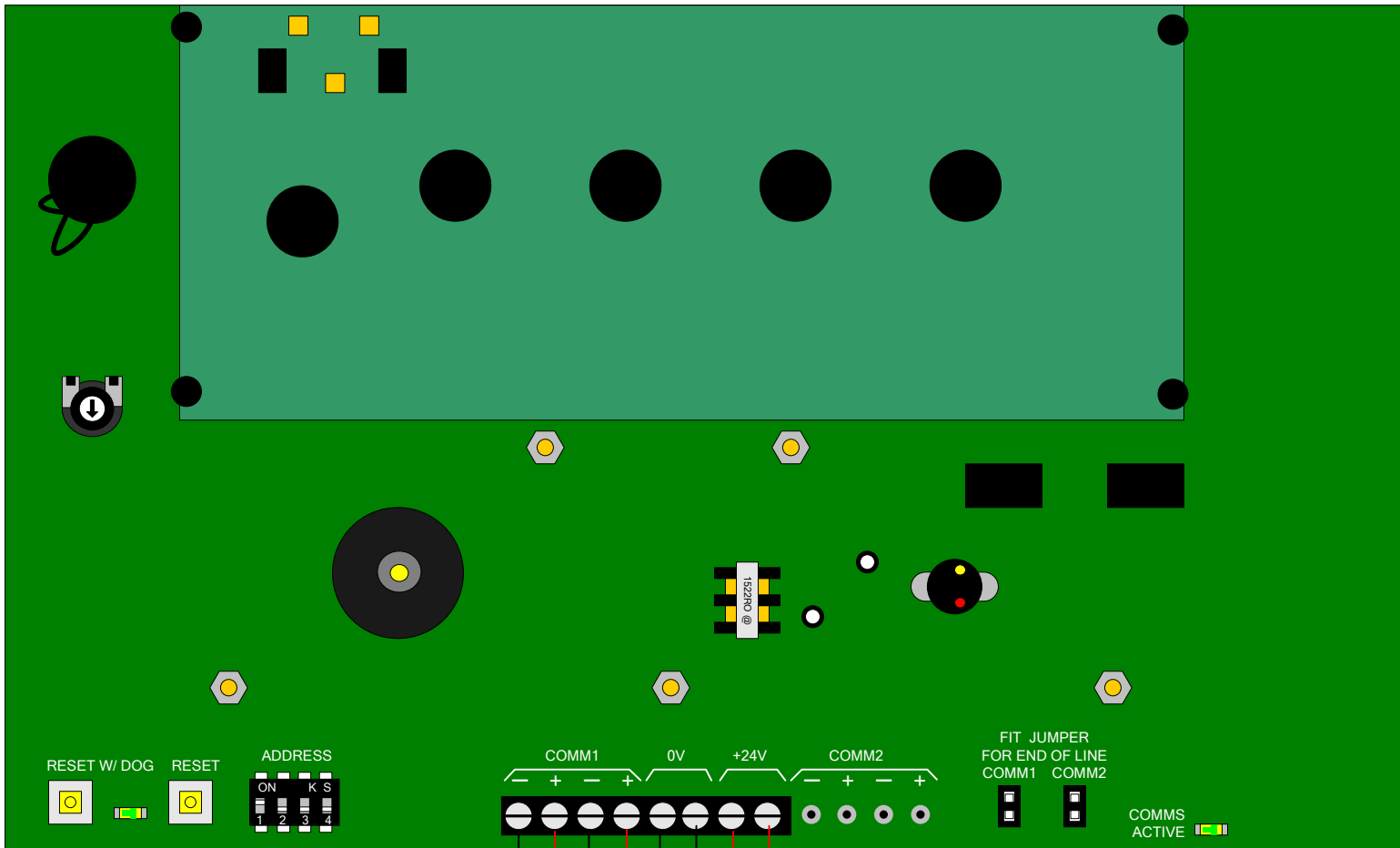

Figure 4.7.2 FN-LCD-S Serial LCD Annunciator

When powering the FN-LCD-S from the FireNET Plus auxiliary 24VDC power (limited to 360mA) or an external UL864/1481 Listed AUX 24VDC supply, the following maximum wiring distances apply to the power cables at the gauges noted:

Wire Run	Wire AWG				
	20	18	16	14	12
1000 ft.	6	9	15	15	15
2000 ft.	3	4	7	12	15
3000 ft.	2	3	5	8	13
4000 ft.	1	2	3	6	10



Reset Switch

DIP Switch used to set the FN-LCD-S address between 1 -15

Not Used

Not Used

RS485 End-of-line jumper. Put jumper in place when FN-LCD-S is the last device on the RS485 bus "I/O Comm".

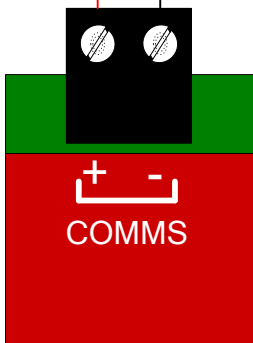

FireNET Plus Control Panel (section)

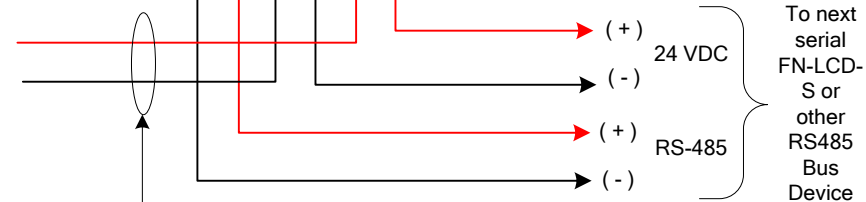

To AUX 24VDC of control panel or to UL 864/1481 listed AUX 24VDC Power Supply

To next serial FN-LCD-S or other RS485 Bus Device

### Figure 4.7.3 FN-LCD-S Wiring Detail

**NOTE:** When connecting I/O boards to the FN-LCD-S via the COMMS terminals shown above, the I/O boards must be powered by a UL864/1481 listed local Auxiliary 24VDC power supply, or the Aux 24VDC output of the FN-LCD-S within the limits outlined below.

DO NOT connect the I/O board power input to the Aux 24VDC output terminals of the FN-LCD-S unless the sum current load of the I/O board is within the 500mA max 24VDC output rating of the FN-LCD-S and within the **360mA** max 24VDC output rating of the FireNET Plus control panel that provides power to the FN-LCD-S. Failure to make this consideration may result in overloading the FN-LCD-S and/or the control panel Aux 24VDC output.

The current limits during both standby and in alarm shall not exceed the **360mA** rating of the FireNET Plus Aux 24VDC output or the 500mA rating of the FN-LCD-S.

The FN-LCD-S current draw is rated as follows:

Standby: 20mA @ 24VDC

Alarm: 110mA @ 24VDC

Available colors are RED, GRAY and CHARCOAL as identified below:

FN-LCD-S-R = RED

FN-LCD-S-C = CHARCOAL

FN-LCD-S-G = GRAY

## Section 5 – SLC Device Installation

---

### 5.1 Compatible SLC Devices

---

The following Hochiki America Corp. SLC devices are listed as compatible with the FireNET Plus analog addressable fire alarm system.

#### **Detectors (Sensors)**

- ALK-V / ALK-V2 Analog Photoelectric Smoke Detector
- ALN-V Analog Photoelectric Smoke Detector
- ALG-V Analog Photoelectric Smoke Detector
- AIE-EA Analog Ionization Smoke Detector
- ATG-EA Analog Heat Detector
- ATJ-EA Analog Fixed Temp / Rate of Rise Heat Sensor
- ACA-V Analog Photoelectric and Heat Multi Detector
- ACC-V Analog Multi Criteria Sensor
- ACD-V Analog CO/ Photo/Heat/ Multi Criteria Sensor
- ACB-EA & ACB-EAW Analog Fixed & Rate of Rise Heat Multi Detector
- DH98-A Analog Duct Smoke Detector, no Relay
- DH98-AR Analog Duct Smoke Detector with Relay
- DH99-A Analog Duct Smoke Detector, no Relay
- DH99-AR Analog Duct Smoke Detector with Relay

Smoke sensors will undergo automatic sensitivity testing and verification every 24 hours.

#### **Modules**

- DCP FRCME-4 / FRCME-M Addressable Input Module
- DCP FRCMA Class A Addressable Input Module
- DCP FRCMA-I Class A Addressable Input Module (with SCI)
- DCP R2M, R2ML, R2MH Addressable Dual Relay Module



- DCP R2ML-I, R2MH-I Addressable Dual Relay Module (with SCI)
- DCP SOM Addressable Supervised Output module
- DCP SOM-A Addressable Class A Supervised Output Module
- DCP SOM-AI Addressable Class A Supervised Output Module (with SCI)
- DCP SCI Short Circuit Isolator
- DCP DIMM Dual Input Monitor Module
- CZM Conventional Zone Module
- ASB Analog Sounder Base
- ASBL Analog Sounder Base Low Frequency
- DCP AMS Addressable Manual Pull-Station
- SOM-R Addressable Supervised Output Module (Preaction Sprinkler Systems)

**NOTE:** The “DCP” prefix listed above on several devices indicates the device’s formal model name as specified by Underwriters Laboratories within each device’s individual listing. The “DCP” prefix will be dropped throughout the body of this manual and the shortened model name will be used. Please take note of this when referencing these devices within this manual.

## ***5.2 Number of Devices***

---

The FireNET Plus comes with 1 SLC loop built-in to the panel. The loop can support up to 127 analog addressable detectors and modules as well as 127 analog sounder bases for a total of 254 possible per loop. By adding the FNP-1127-SLC expander card, 1 additional SLC loop can be added to the panel for a total of 2 loops.

Addresses 1 – 127 are reserved for any combination of detectors and modules. Addresses 128 – 254 are reserved for analog sounder bases. Detectors and modules cannot be addressed to the upper address 128 - 254. Each device on the SLC loop must have a unique address. Refer to section 5.4 for instructions on programming the address into each analog addressable device.

### 5.3 SLC Loop Wiring

The FireNET Plus uses the patented Hochiki DCP Digital Communication Protocol to communicate with each of the analog addressable devices located on the SLC loops. This extremely fast and reliable protocol allows the use of standard non-twisted, non-shielded wiring for the SLC loops.

The SLC loop wiring may be any solid or stranded cabling that meets the requirements for power limited fire protective signaling circuits listed in NFPA 70 (National Electrical Code) Article 760. The wiring resistance on the SLC loop must be less than 50 ohms. Loop capacitance must be less than 1 $\mu$ F. Loop inductance must be less than 1mH.

The terminals for SLC loop 1 are located on the top of the main control board. See Figure 5.3.

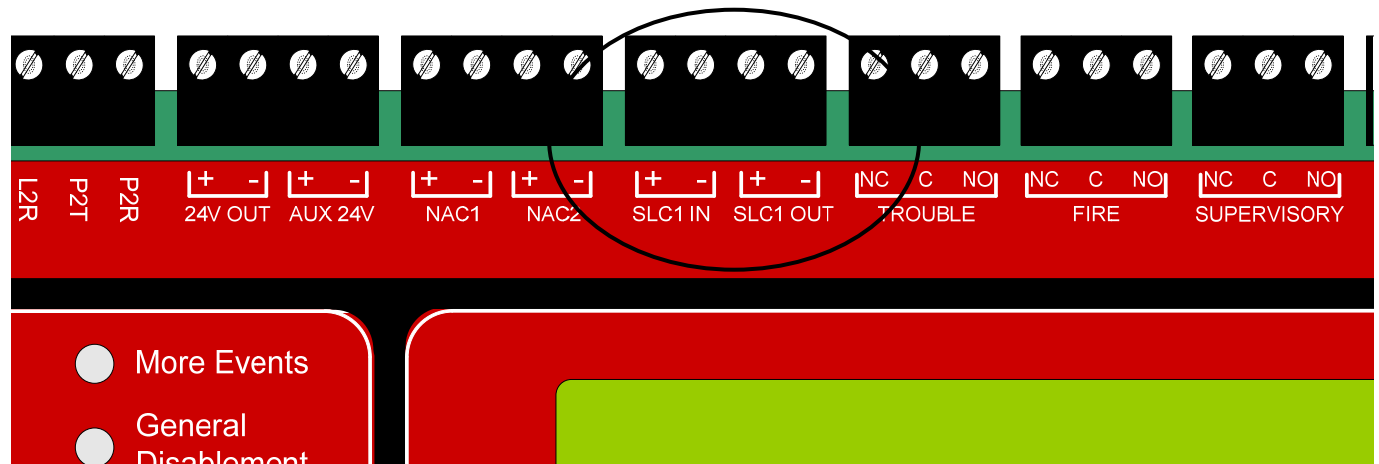
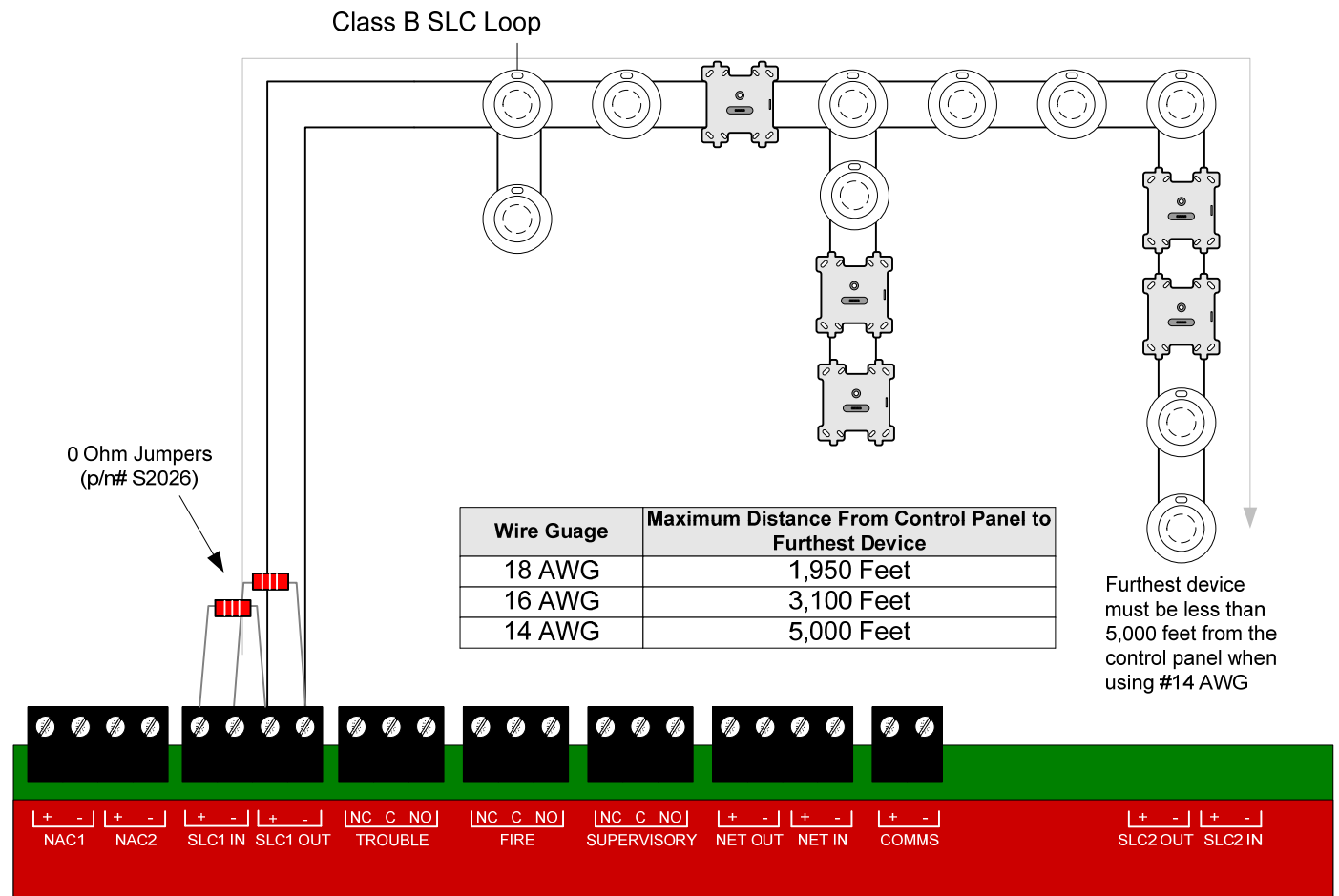

Figure 5.3 SLC Loop Terminals

### 5.3.1 Class B SLC Loop Wiring Distance

Refer to Figure 5.3.1 to determine the maximum length of wire that may be used on a Class B signaling line circuit (SLC). The total wire length of all branches (T-taps) on the SLC loop must not exceed 5,000 feet\* (per loop) using #14 AWG (see Figure 5.3.2). When using a Class B SLC wiring configuration, be sure that the 0 ohm jumpers supplied with the panel are properly installed between -OUT to -IN and +OUT to +IN (Part # S2026).



**Figure 5.3.1 Maximum Wiring length for a Class B SLC**

\*The total resistance per circuit must be less than 50 ohms, the total capacitance per circuit must be less than 1µF, and the total inductance per circuit must be less than 1 mH.

Class B SLC Loop (with T-taps)

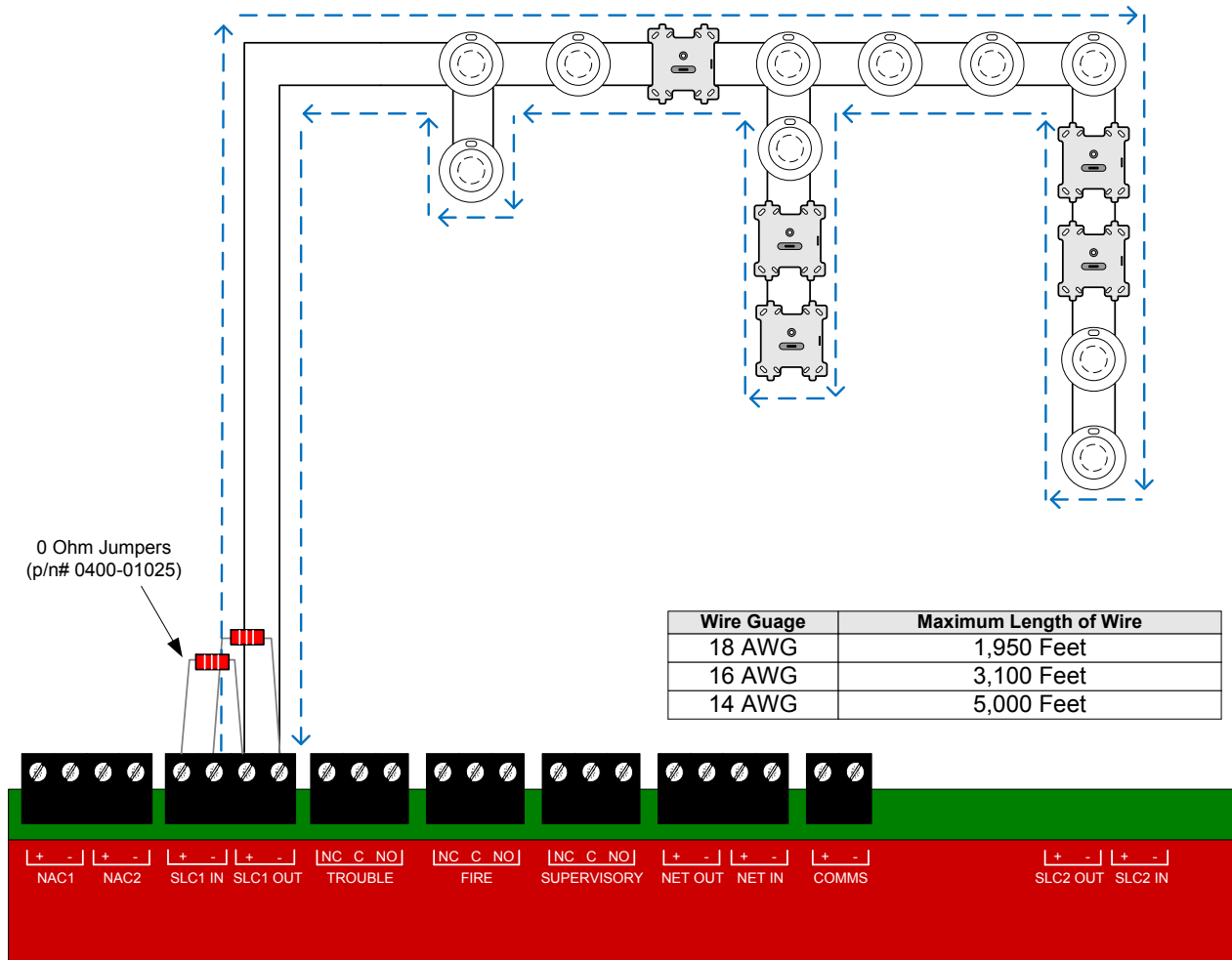
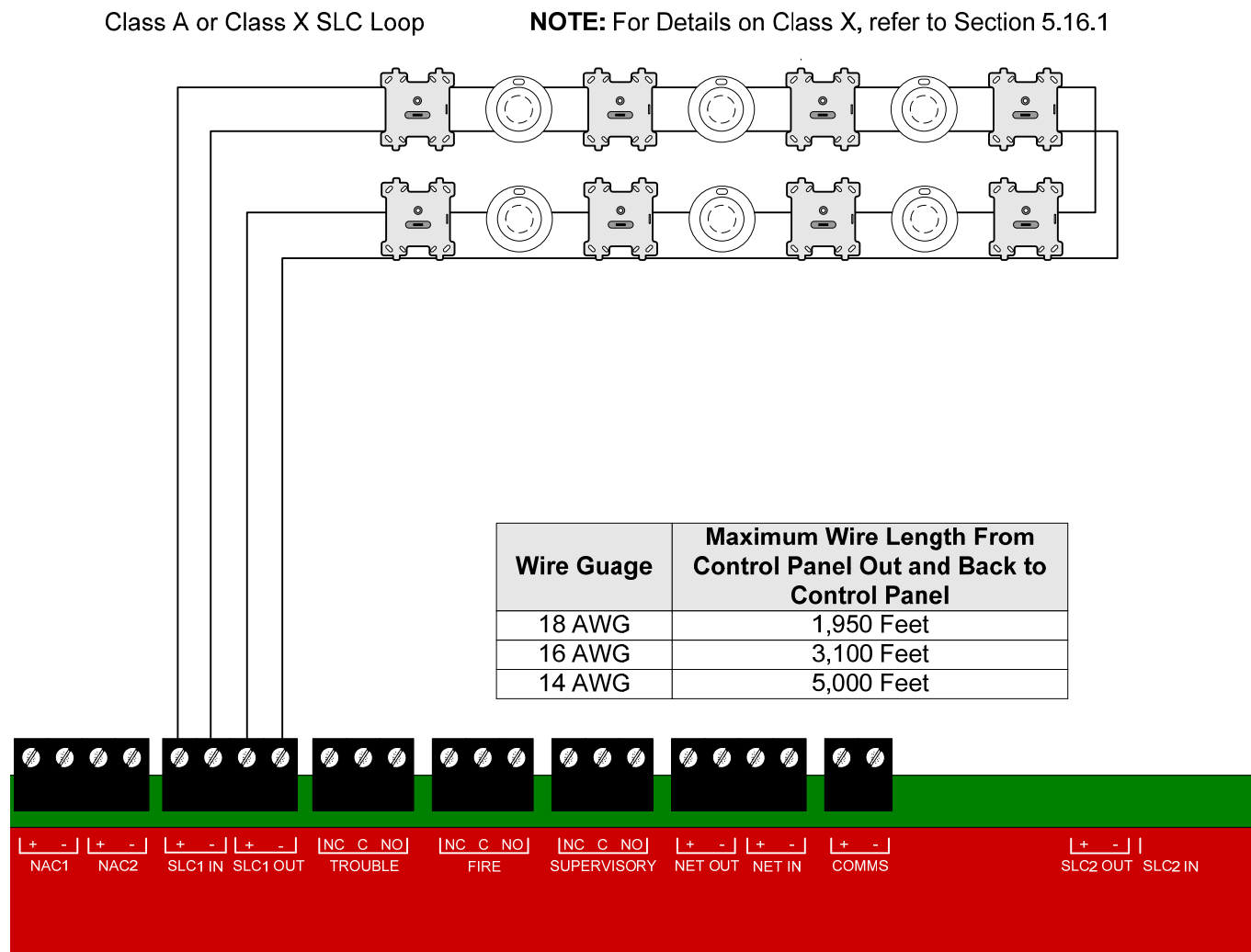

Figure 5.3.2 Maximum Wiring Length for a Class B SLC with T-Taps

### 5.3.2 Class A SLC Loop Wiring Distance

Refer to Figure 5.3.3 to determine the maximum length of wire that may be used on a Class A signaling line circuit (SLC) .



**Figure 5.3.3 Maximum Wiring Distance for a Class A SLC**

The SLC wiring must always meet the following requirements (per circuit):

- The total Resistance must be less than 50 ohms
- The total Capacitance must be less than 1µF
- The total Inductance must be less than 1mH

1 – Class X circuits were previously designated “Class A Style 7” circuits. See Chapter 12 of NFPA 72, 2013 Edition.

## Additional Notes Regarding Class A SLC loops:

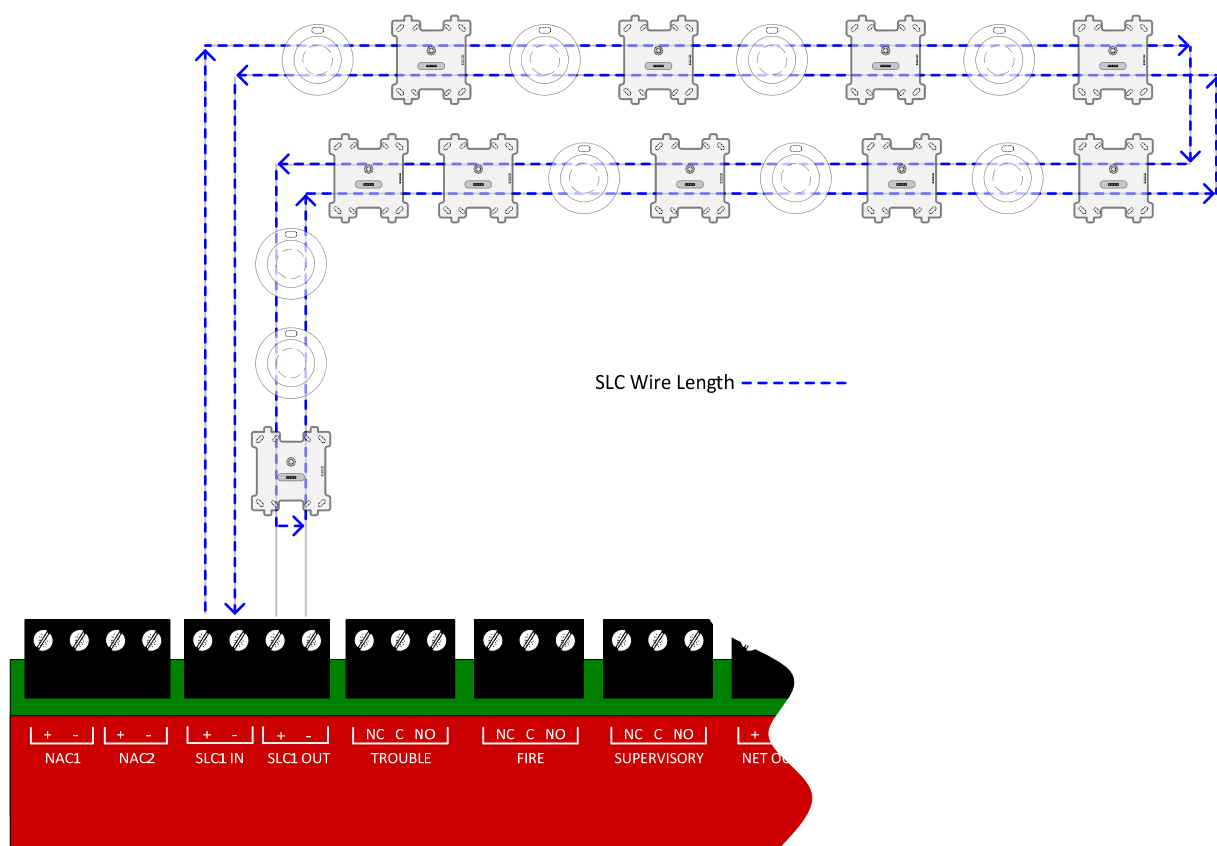

- No t-taps are allowed on a Class A / Class X SLC loop.
- The return side of the loop must be routed separately from the outgoing loop.
- The return side may not share the same conduit or cable as the outgoing side of the SLC loop.
- When using Class X wiring, SCI Short Circuit Isolators must be installed before and after each analog addressable device on the SLC loop. Alternatively analog devices with built-in SCI may be used. The wiring from the control panel to the first SCI and from the last SCI back to the control panel must be in conduit. Refer to Section 5.16 for more information on installing the SCI module and for installation methods to satisfy Class X criteria per NFPA 72.
- Refer to NFPA 72 for additional requirements of Class A circuits.

## 5.4 Addressing Devices

---

Prior to installation, all of the addressable devices installed on the FireNET Plus SLC loop must be programmed with a unique address ranging from 1 to 127. The analog sounder bases will automatically derive their address from the host sensor (detector) attached to them. The ASB (ASBL) address will be the sensor address + 127 (i.e.  $N + 127$ ). Example: The sensor address is 36.  $36 + 127 = 163$ . The ASB (ASBL) will have an address of 163. This address is what the FireNET Plus control panel uses to identify each addressable device and control its functionality. All Hochiki addressable devices come from the factory preset to address 127. This preset address can be reprogrammed using the Hochiki TCH-B100-NS programmer. Follow these instructions to set/reprogram the address.

1. Identify each analog addressable device that will be installed on the SLC loop and label it with a unique address ranging from 1 to 127.
2. Using the Hochiki TCH-B100-NS programmer as shown in Figure 5.4, program the appropriate address into each analog addressable device.

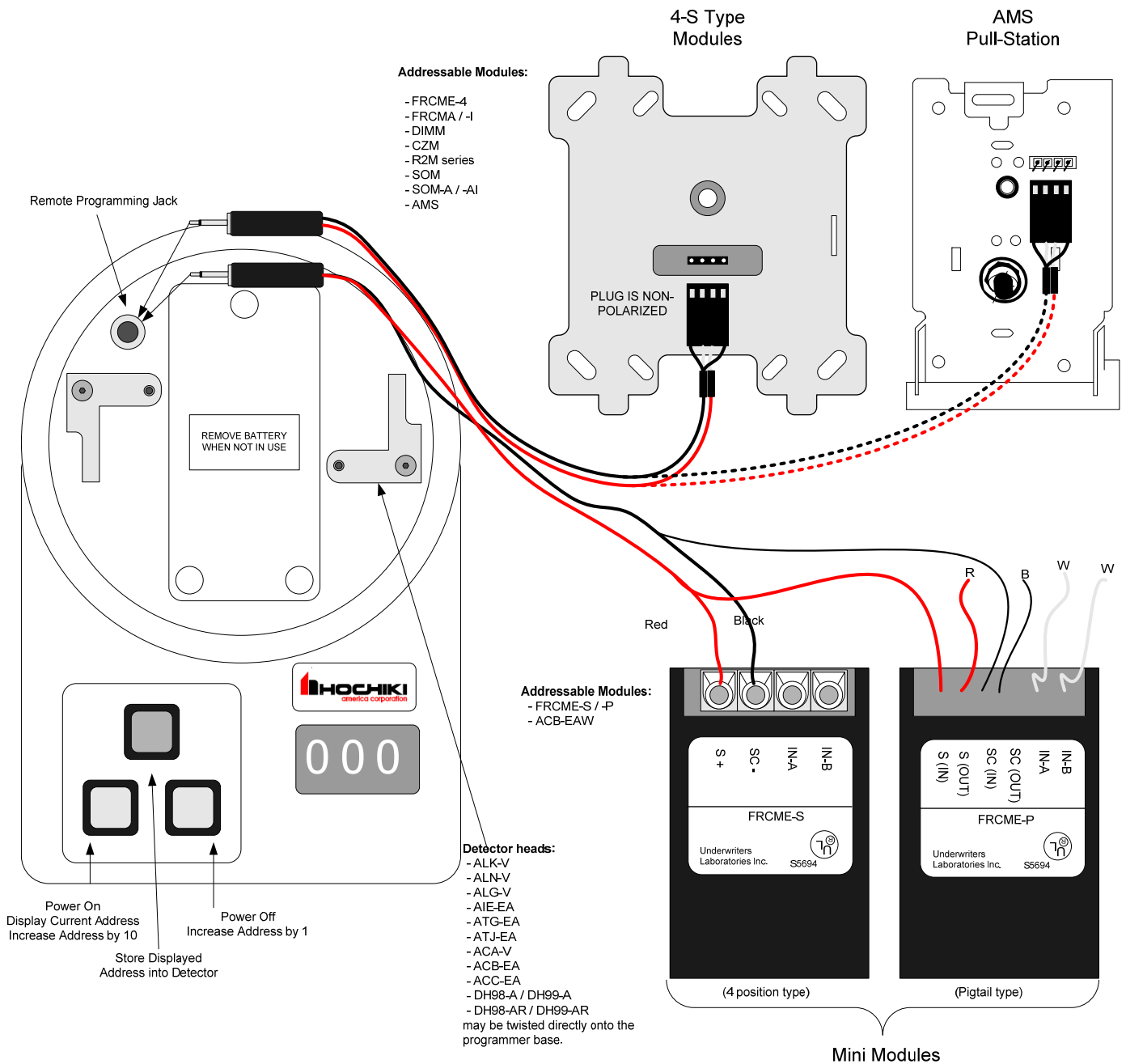

**Figure 5.4 Hochiki TCH-B100-NS Programmer Connections**

1. The ASB (ASBL) automatically derives its address from the host sensor (N + 127).
2. Devices must not be powered when using the TCH-B100-NS programmer to set addresses.
3. Mini-modules such as the FRCME-S and FRCME-P should not be connected to the SLC loop when using the TCH-B100-NS programmer to set addresses.
4. When programming the AMS, use the same method as the 4-S type addressable modules.



### 5.4.1 Detector Addressing

This section applies to the following Hochiki analog detectors – ALK-V, ALK-V2, ALG-V, ALN-V, AIE-EA, DH-98-A(R), DH-99-A(R), ATG-EA, ATJ-EA, ACA-V, ACB-EA and ACC-V. Follow these steps to program a new address into any one of these analog detectors. (Refer to Figure 5-4)

1. Twist an analog detector head on to the programmer terminals.
2. Press the left gray button to turn on the programmer and read/display the current address in the detector head. (Factory default is address 127)
3. Using the left gray button you can increase the tens digit one number at a time. Using the right gray button you can increase the ones digit one number at a time. Using these buttons change the displayed address to the appropriate value.
4. Press the red button to store the displayed address into the detector head.

### 5.4.2 4” Modules and AMS Addressing

This section applies to the following Hochiki addressable modules - FRCME-4, R2M series, DIMM, CZM, SOM series, and AMS. Follow these steps to program a new address into any of these addressable modules. (Refer to Figure 5-4)

1. Using the dual-end programming plug provided with the programmer, plug one end into the jack on the programmer and plug the other end into the programming plug located on the front of the module plate. The plug is non-polarized and can be connected in either orientation.
2. Press the left gray button to turn on the programmer and read/display the current address in the module.
3. Using the left gray button you can increase the displayed address 10 numbers at a time. Using the right gray button you can increase the displayed address one number at a time. Using these buttons change the displayed address to the appropriate value.
4. Press the red button to store the displayed address into the addressable module.

### 5.4.3 Mini Module Addressing

This section applies to the Hochiki FRCME-S and FRCME-P addressable mini-module. Follow these steps to program a new address into any of these addressable modules. (Refer to Figure 5-4)

1. Using the programming plug with alligator clips, plug the end with the jack on it into the programming jack on the programmer.
2. Connect the Red alligator clip to the wire labeled **S (+)** on the addressable module. Connect the Black alligator clip to the wire labeled **SC (-)** on the addressable module.
3. Press the left gray button to turn on the programmer and read/display the current address in the module.
4. Using the left gray button you can increase the displayed address 10 numbers at a time. Using the right gray button you can increase the displayed address one number at a time. Using these buttons change the displayed address to the appropriate value.
5. Press the red button to store the displayed address into the addressable module.

## 5.5 Smoke and Heat Detector Wiring

This section includes wiring instructions for connecting the following analog detectors to the FireNET Plus fire alarm control panel: ALK-V / ALK-V2, ALN-V Photoelectric Smoke Detector, ALG-V Photoelectric Smoke Detector, AIE-EA Ionization Smoke Detector, ATG-EA, ATJ-EA Heat Detector, ACA-V, ACC-V Multi Detector, ACB-EA / EAW Fixed and Rate of Rise Multi Heat Detector. All FireNET analog detectors must be installed using an YBN-NSA-4 four-inch detector base, or a HSB-NSA-6 six-inch detector base.

ACD-V Multi Sensors which are used in CO modes should be connected to ASBL sounder bases in order to support the temporal 4 output required for CO.

For detailed instructions on the physical mounting of FireNET analog smoke and heat detectors please refer to the installation instructions that are included with each analog detector.

Prior to installing any analog detector or module you must set its address as described in section 5.4.

Wire the analog smoke and heat detector bases as indicated in Figure 5.5.

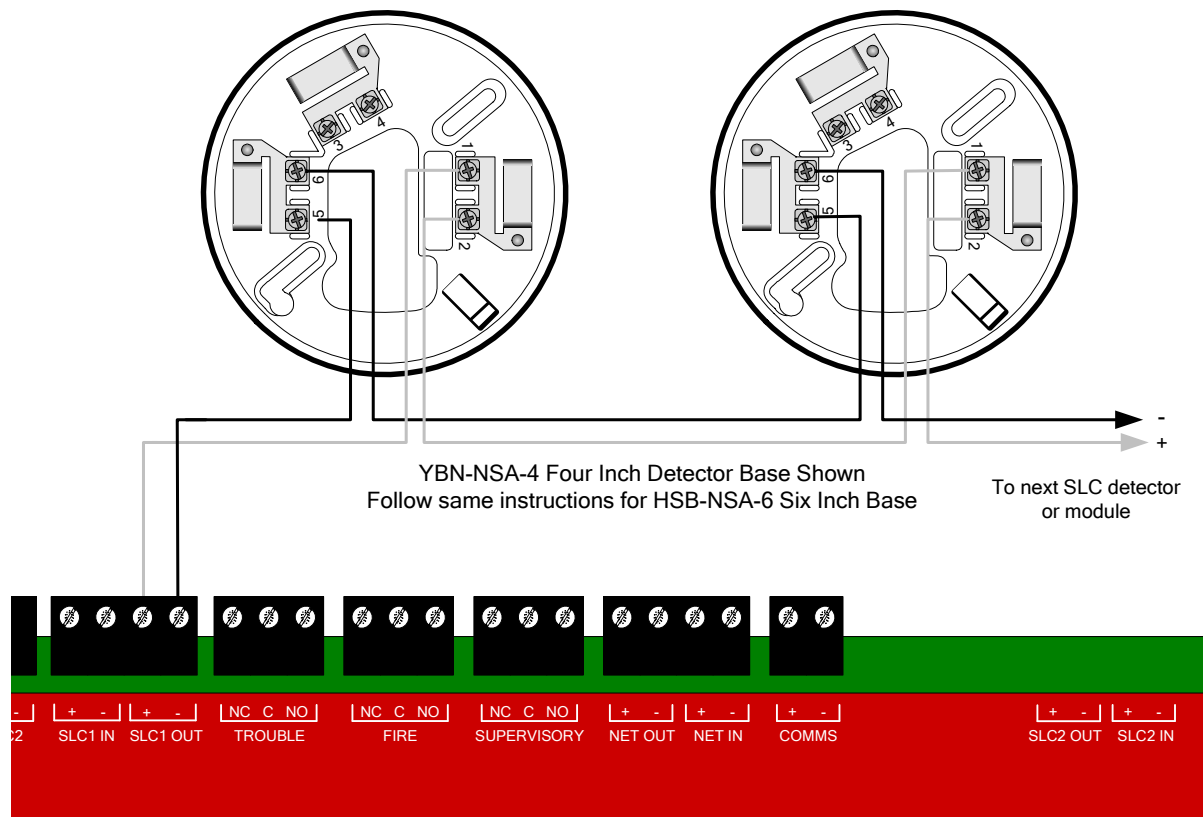

Figure 5.5 Analog Detector Base Wiring

## 5.5.1 ACD-V CO Multi-Sensor Configuration

### ACD-V CO Multi-Sensor Configuration

The ACD-V can be programmed to operate in 16 different modes, either through the menu keys of the panel in level 3, or through Loop Explorer 2 programming software. By default (either through a panel auto-learn, or default settings of Loop Explorer 2), the detector is set to the following parameters:

- Mode [Day & Night]
  - Photo Smoke Detection Active
  - Carboxyhemoglobin (COHb) Detection Active
  - Reduced False Alarm Algorithm Active
- PreAlarm detection Active
- Detector Polling LED Active
- Smoke detection will create a Fire Event
- (COHb) detection will create a CO Event

Using the Sensor Properties tab in Loop Explorer 2 changes can be made to the Sensitivity properties, mode of Operation, Pre-Alarm Value, LED polling or other Operational parameters (See Image Below).

Using the Level 3 soft menu keys in the panel Sensitivity, Mode and Polling LED settings can be edited.

ACD-V CO Sensor at Address 001.01

Change Address

Input Properties | **Sensor Properties**

**Sensitivity**

Alarm Value [Open PDF](#)

	S/H/CO	S/H	Smoke	CO/H
Day	4	3.0	3.0	4
Night	4	3.0	3.0	4

	CO	H(FT)	H(RoR)	COHb
Day	4	135	39	6.2
Night	4	135	39	6.2

**Polling LED**

No Flash

**Mode**

Day: +S +COHb

Night: +S +COHb

**Pre Alarm Value**

Indicate Pre Alarm

Smoke-Heat-CO Multi	3.5	Smoke-Heat Multi	2.5
Smoke	2.5	FT	120
RoR	30	CO-Heat Multi	3.5
CO	3.5	COHb	5.2

**Location Text**

CO Detector Room 26

Zone: 1

Save Cancel

## 5.6 Analog Duct Detector Wiring

This section includes wiring instructions for connecting the DH98-A, DH99-A analog duct detector, and the DH98-AR and DH99-AR analog duct detector with relay, to the FireNET Plus control panel SLC loop.

For detailed instructions on the physical mounting and wiring of FireNET analog duct detectors please refer to the installation instructions that are included with each device.

Prior to installing any analog detector or module you must set its address as described in section 5.4. You will need to remove the smoke detector head from the base in the duct detector in order to program it.

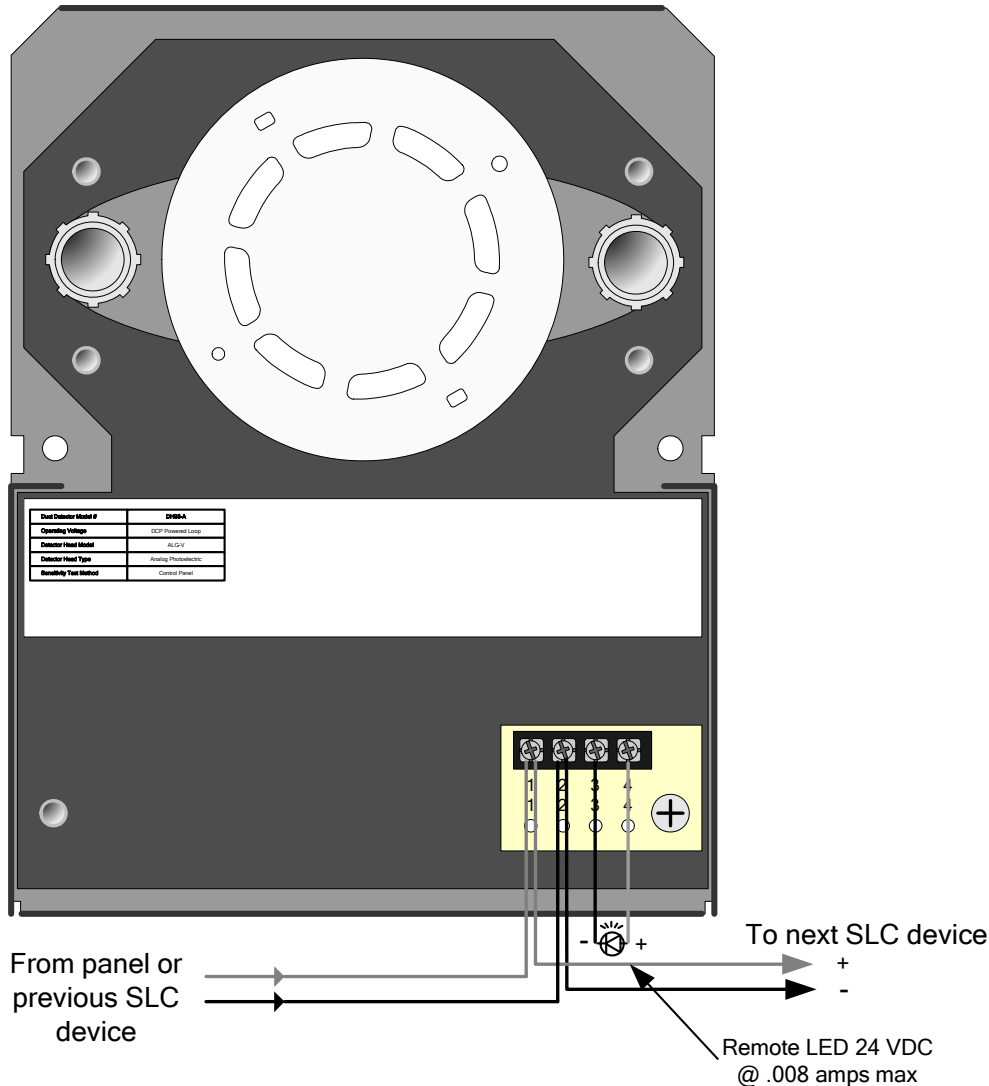

Figure 5.6.1 DH98-A Analog Duct Detector

## 5.6.1 DH98-A Analog Duct Detector

Connect the DH98-A analog duct detector to the FireNET Plus control panel SLC loop as shown in Figure 5.6.1.

Terminals 3 and 4 can be used to power a remote alarm LED. The ratings on these terminals are 24 VDC at .008 amps maximum. Please note the number of alarm LED's that can be illuminated at one time is limited to 5 addresses per SLC loop by the control panel.

**NOTE:** The duct sensor LED and remote LED output only activate momentarily when in alarm.

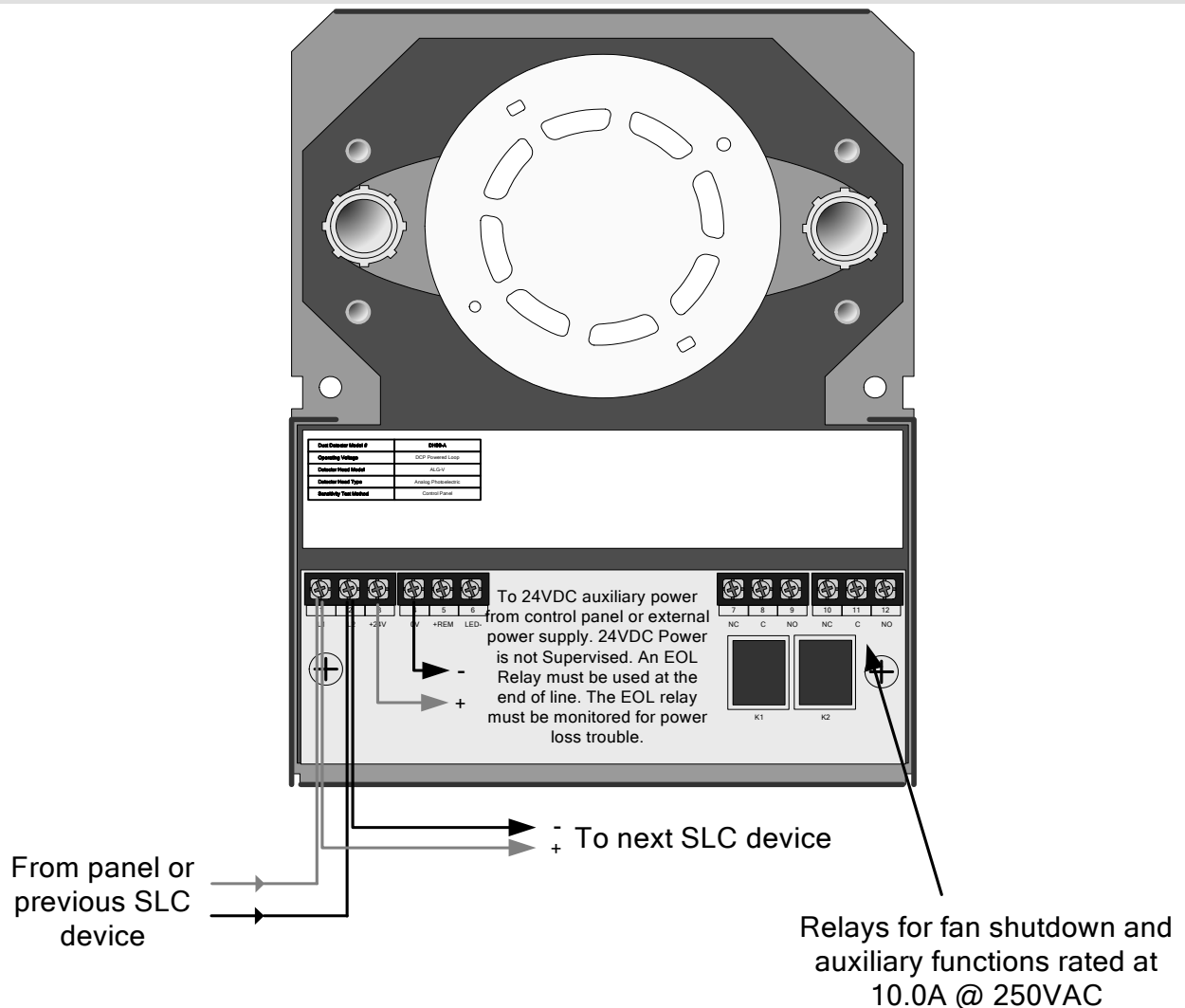

Figure 5.6.2 DH98-AR Duct Detector with Relays

## 5.6.2 DH98-AR Analog Duct Detector with Relay

Connect the DH98-AR analog duct detector with relays, to the FireNET Plus control panel SLC loop as shown in Figure 5.6.2.

In addition to the SLC loop connections, the DH98-AR requires 24-volt reset-able auxiliary power (10mA standby and 55mA alarm) connected to terminals 3+ and 4-. This power may come from the FireNET Plus main control panel auxiliary power (360 mA max.) or from an external power supply.

The DH98-AR analog duct detector contains 2 sets of form C alarm contacts rated at 10.0 amps @ 250 VAC that can be used for fan shutdown and other auxiliary functions.

In addition to the alarm contacts the DH98-AR also has connections for a remote test switch as well as outputs for a remote alarm and remote pilot light LED's.

**NOTE:** The test switch only activates output relays; it does not place the detector into alarm.

## 5.7 FRCME-4 Input Module Wiring

The FRCME-4 input module is used to connect standard normally open dry contact types of fire alarm devices such as pull stations, waterflow, or tamper switches to the FireNET Plus SLC loop. More than one switch can be connected to a FRCME-4 however you must not mix multiple switch types on a single FRCME-4. *For example: three waterflow switches connected to a single FRCME-4 is acceptable. However, two waterflow switches and one valve tamper switch connected to a single FRCME-4 is not.* NFPA and local codes may also apply.

The FRCME-4 must be programmed with a unique address from 1-127. All of the switches connected to a single FRCME-4 appear at the main control panel as a single address. Please refer to section 5.4 of this manual for instructions on programming an address into the FRCME-4 input module.

Connect the FRCME-4 to the FireNET Plus as shown in figure 5.7.1. Refer to the installation instructions included with the FRCME-4 for more detailed installation and wiring instructions.

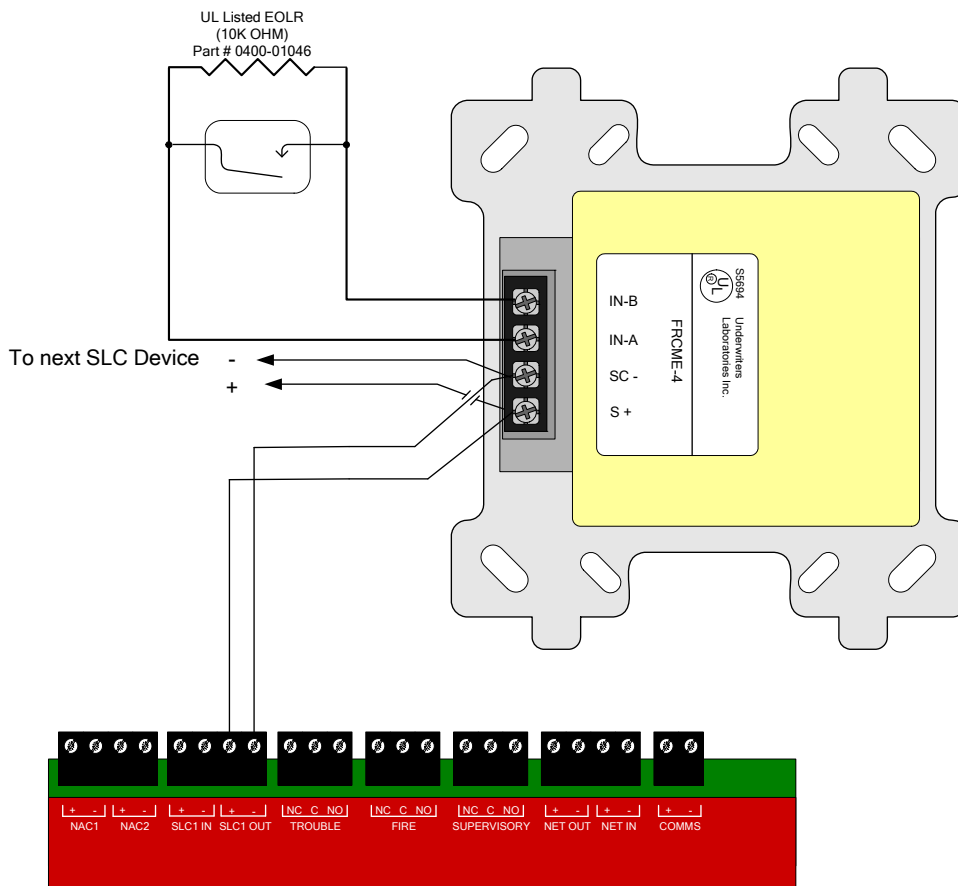

Figure 5.7.1 FRCME-4 Input Module Wiring Detail



## 5.8 FRCME-M Mini Input Module (w/ Terminal Blocks)

The FRCME-M input module is used to connect standard normally open dry contact types of fire alarm devices such as manual pull stations to the FireNET Plus SLC loop.

The FRCME-M must be programmed with a unique address from 1-127. All of the dry contact type devices connected to a single FRCME-M appear at the main control panel as a single address. Please refer to section 5.4 of this manual for instructions on programming an address into the FRCME-M input module.

Connect the FRCME-M to the FireNET as shown in figure 5.8.1. Refer to the installation instructions included with the FRCME-M for more detailed installation and wiring instructions.

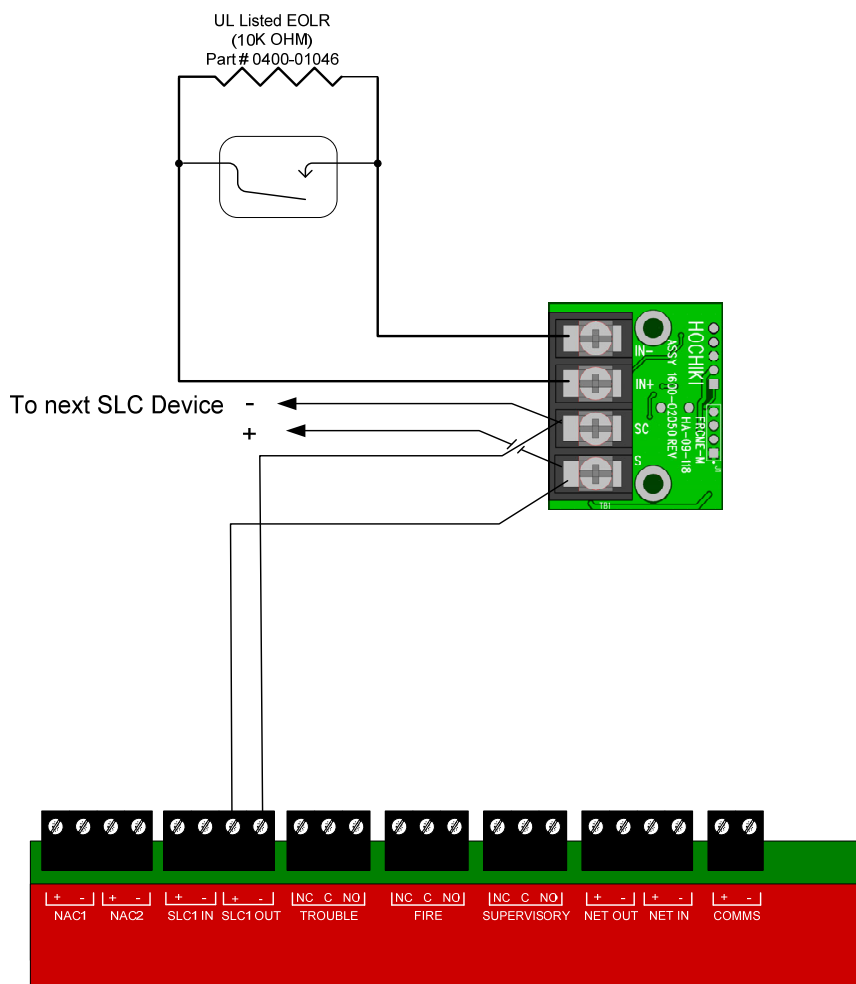

Figure 5.8.1 FRCME-M Mini Input Module (w/ Terminal Blocks) Detail

## 5.9 FRCMA / FRCMA-I Input Module

The FRCMA / FRCMA-I input module is used to connect standard normally open dry contact types of fire alarm devices such as manual pull stations to the FireNET Plus SLC loop. The FRCMA module provides one class A or one class B input circuit. The FRCMA-I includes built-in short circuit isolation for the SLC loop.

The FRCMA must be programmed with a unique address from 1-127. All of the dry contact type devices connected to a single FRCMA are displayed at the main control panel as a single address. Please refer to section 5.4 of this manual for instructions on programming an address into the FRCMA input module.

Connect the FRCMA to the FireNET Plus as shown in figure 5.9.1. Refer to the installation instructions included with the FRCMA for more detailed installation and wiring instructions.

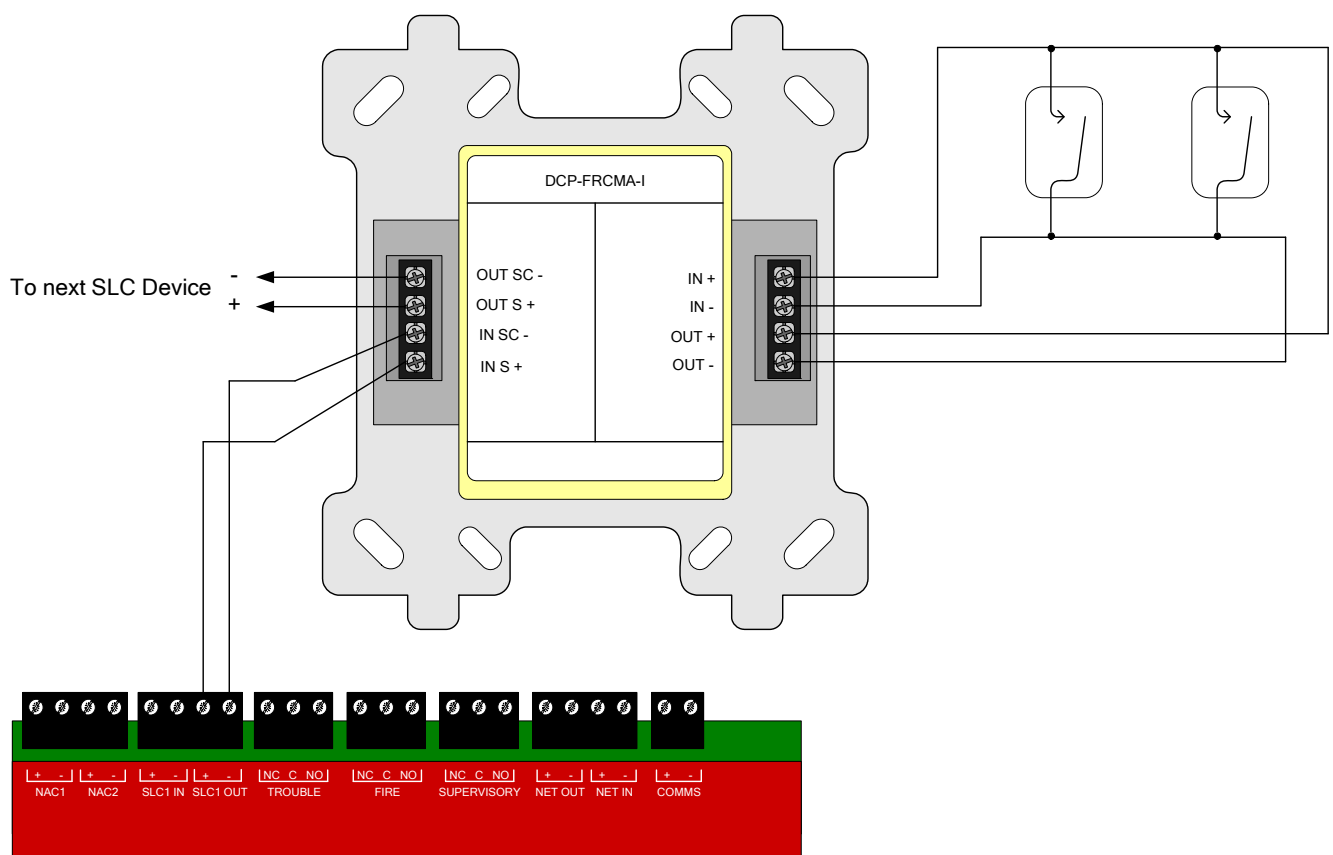

Figure 5.9.1 FRCMA-I Input Module Class A Detail

**NOTE: For Sections 5.7, 5.8, and 5.9 common for all FRCM devices**

---

Reference the input wiring distance limitation table below for all types of FRCM modules:

<b>Maximum Distance Between Module and EOL Device</b>	
14 AWG	1500 Ft.
16 AWG	900 Ft.
18 AWG	550 Ft.

## 5.10 R2M Dual Relay Module Wiring

The R2M modules provide two separately programmable relay outputs on the FireNET Plus SLC loop. These outputs may be used for a variety of purposes including door holders, elevator recall, and other fire safety functions.

The programmable relay contacts are rated as follows

- **R2M** - 1.0A @ 30VDC or 0.5A @ 125VAC, 0.35 Power Factor (PF)
- **R2ML/R2ML-I** – 2.0A @ 30VDC, 1PF or 0.5A @ 120VAC, 0.6PF
- **R2MH/R2MH-I** – 8.0A @ 30VDC or 8.0A at 250VAC Resistive, 1.0PF or 4.8A @ 250VAC, 0.6PF.

The R2ML-I and R2MH-I modules have built-in Short Circuit Isolation (SCI) for the SLC loop.

Connect the R2M module as shown in Figure 5.10.1. Refer to the installation instructions included with the R2M for more detailed wiring and installation instructions.

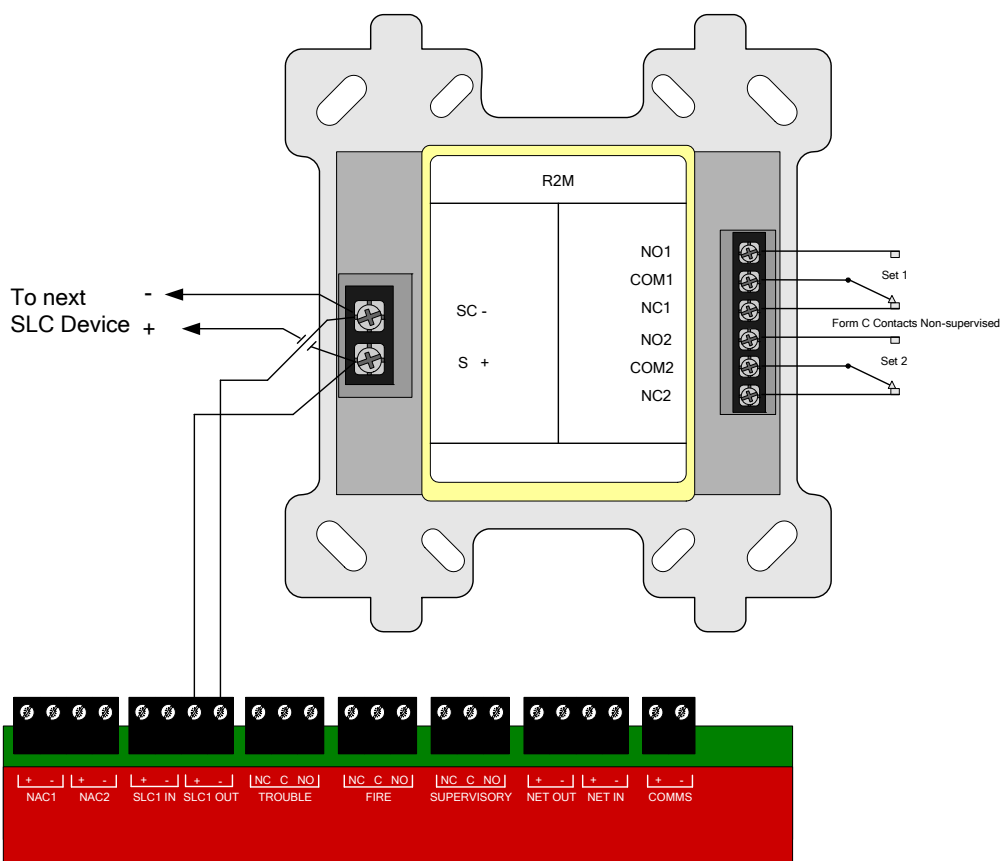

Figure 5.10.1 R2M Dual Relay Module Wiring Detail

## 5.11 SOM Supervised Output Module

The SOM provides a supervised 24VDC polarity reversing output on the SLC loop most commonly used for audible and visual signaling appliances or triggering a remote notification appliance circuit power expander.

In addition to the SLC circuit the SOM requires a 24 VDC auxiliary input voltage. This voltage may be obtained from the FireNET Plus control panel auxiliary power (360ma max) or to any other UL listed fire alarm power supply providing 24 VDC.

The supervised voltage output of the SOM is rated at 2.0A maximum.

Connect the SOM to the FireNET Plus control panel as shown in Figure 5.11.1. Refer to the installation instructions included with the SOM for more detailed wiring and installation instructions. Take care to install wiring so that faults on installation conductors do not affect more than one notification zone. The DCP-SOM is suitable for use only with non-synchronized audible devices.

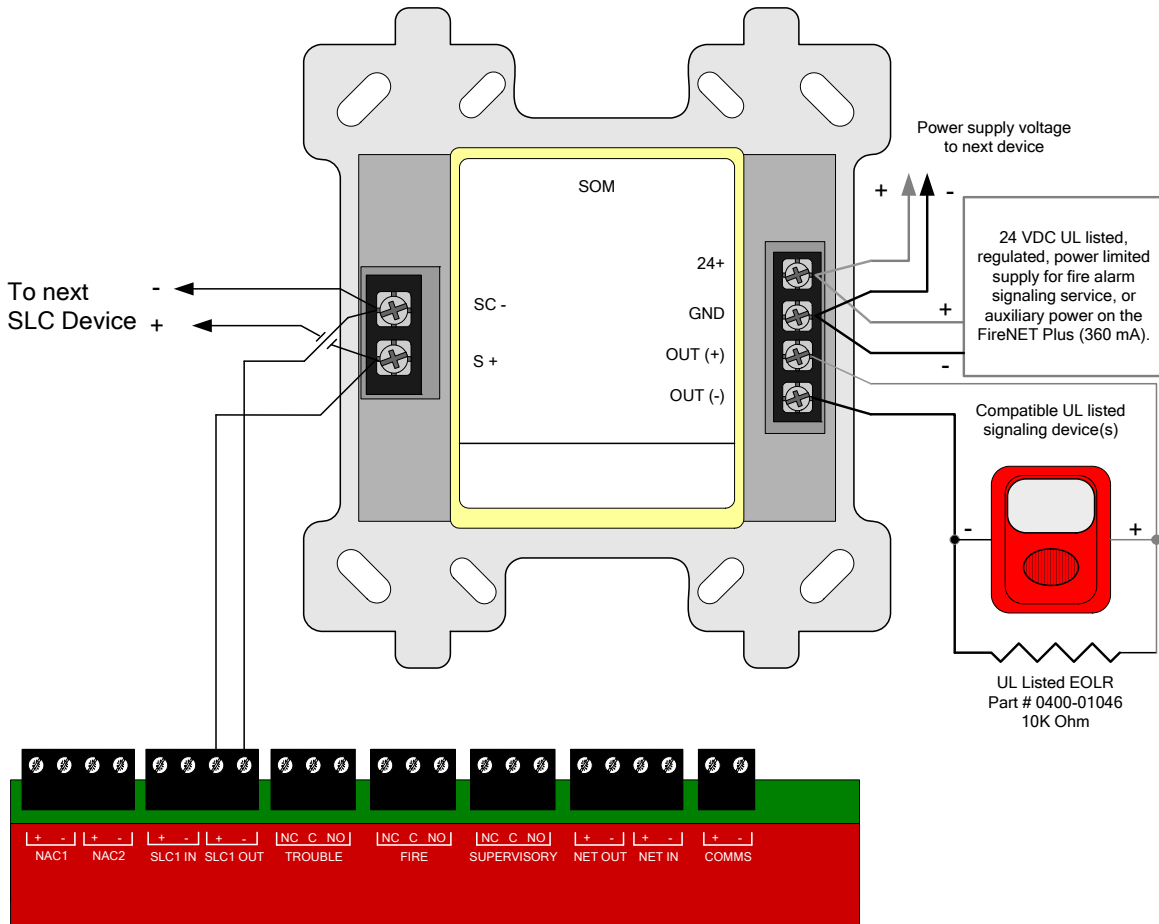

Figure 5.11.1 SOM Supervised Output Module Detail

## 5.12 SOM-A / SOM-AI Supervised Class A Output Module

The SOM-A / SOM-AI provides a supervised 24VDC polarity reversing Class A output on the SLC loop. This module is most commonly used for audible and visual signaling appliances or for triggering a remote notification appliance circuit power expander. The SOM-AI includes built-in short circuit isolation (SCI).

In addition to the SLC circuit the SOM-A / SOM-AI requires a 24 VDC auxiliary input voltage. This voltage may be obtained from the FireNET Plus control panel auxiliary power (360ma max) or to any other UL listed fire alarm power supply providing 24 VDC. The supervised voltage output of the SOM-A / SOM-AI is rated at 2.0A maximum.

Connect the SOM-AI to the FireNET Plus control panel as shown in Figure 5.12.1. Note that the SLC connections for the SOM-A are like the SOM; there is only one S+ and one SC-terminal. Refer to the installation instructions included with the SOM-A / SOM-AI for more detailed wiring and installation instructions. Take care to install wiring so that faults on installation conductors do not affect more than one notification zone. The SOM-A / SOM-AI is suitable for use only with non-synchronized audible devices.

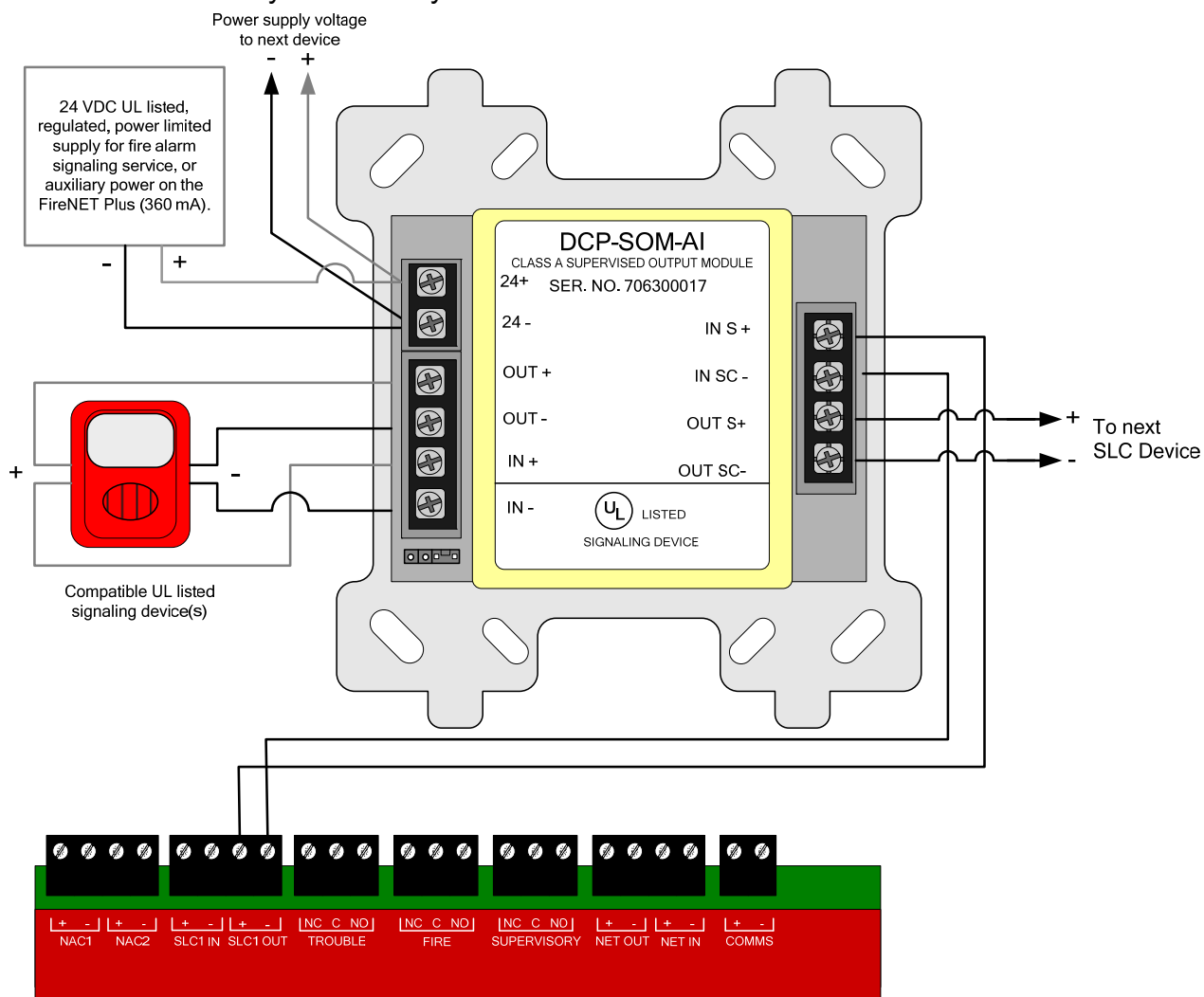

Figure 5.12.1 SOM-AI Supervised Output Module Detail

**Note regarding the use of Sync Modules with the SOM-A and SOM-AI:** The DCP-SOM-A and DCP-SOM-AI modules are suitable for use with Amseco/Potter, Wheelock and Gentex notification appliances in both a Class A and Class B configuration with the appropriate manufacturer's sync module employed.

The DCP-SOM-A and DCP-SOM-AI modules are suitable for use with System Sensor notification appliances in a Class B configuration with the System Sensor sync module employed.

The DCP-SOM-A and DCP-SOM-AI modules are NOT suitable for use with the System Sensor notification appliances when connected to the System Sensor sync module in a Class A configuration.

## 5.13 SOM-R Supervised Output Module (Preaction Sprinkler Systems)

The SOM-R provides a supervised 24VDC output on the SLC loop for use with solenoids used in a single interlock, preaction sprinkler system.

The SOM-R consists of an output module, a polarized end-of-line device, and a keyswitch module that is used to disable the output of the SOM-R.

The SOM-R requires connections to the SLC and a 24 VDC auxiliary input voltage. The keyswitch disable module must be connected to the SLC and to the output of the SOM-R module.

The supervised voltage output of the SOM-R is rated at 2.0A maximum.

The alarm time for the SOM-R battery calculation shall be 5 minutes in the “active status”.

**NOTE:** These installation instructions must be followed completely in order to comply with agency requirements! Failure to follow these installation instructions may result in improper operation of the SOM-R.

1. Determine the mounting location for the SOM-R, FRCME and SOM-R-DS keyswitch. These should be installed in the same location, or as required by your AHJ.

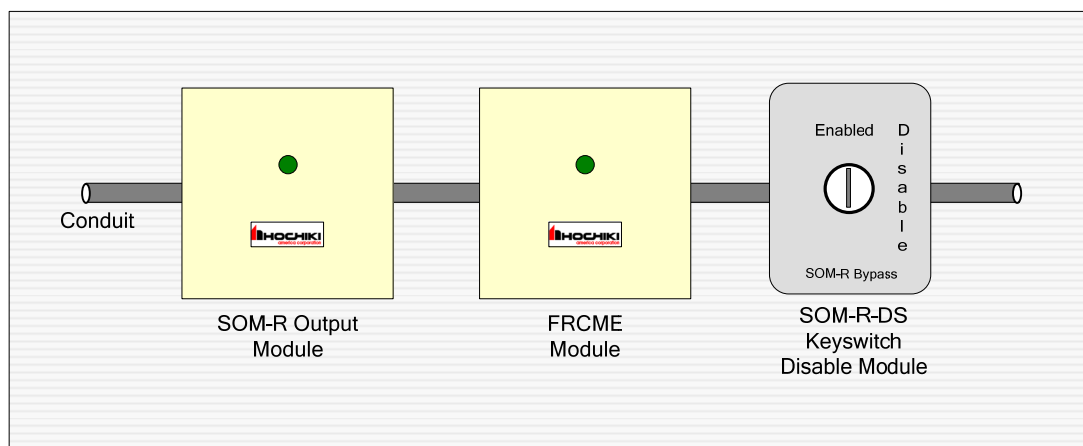

2. The SOM-R must be addressed using the TCH-B100 programmer. Connect the SOM-R to the FireNET Plus SLC as shown in Figure 5.13.1. Refer to the installation instructions (Part # 1700-11320, Rev. 05/10) included with the SOM-R for additional wiring and installation instructions.

3. Connect 24VDC power to the SOM-R module. This voltage may be provided by; 1) a UL 1481 listed, regulated, power limited supply, 2) a FireNET Plus NAC circuit configured as continuous auxiliary power, or 3) the FireNET Plus aux power

4. The SOM-R-DS keyswitch connected to the FRCME module must be connected to the FireNET SLC. Use the TCH-B100 programmer to assign an address to the module and then connect the SLC circuit to the S+ and SC- terminals on the module.



5. Connect the output of the SOM-R to the input terminals on the SOM-R-DS keyswitch connected to the FRCME module. Ensure correct polarity.

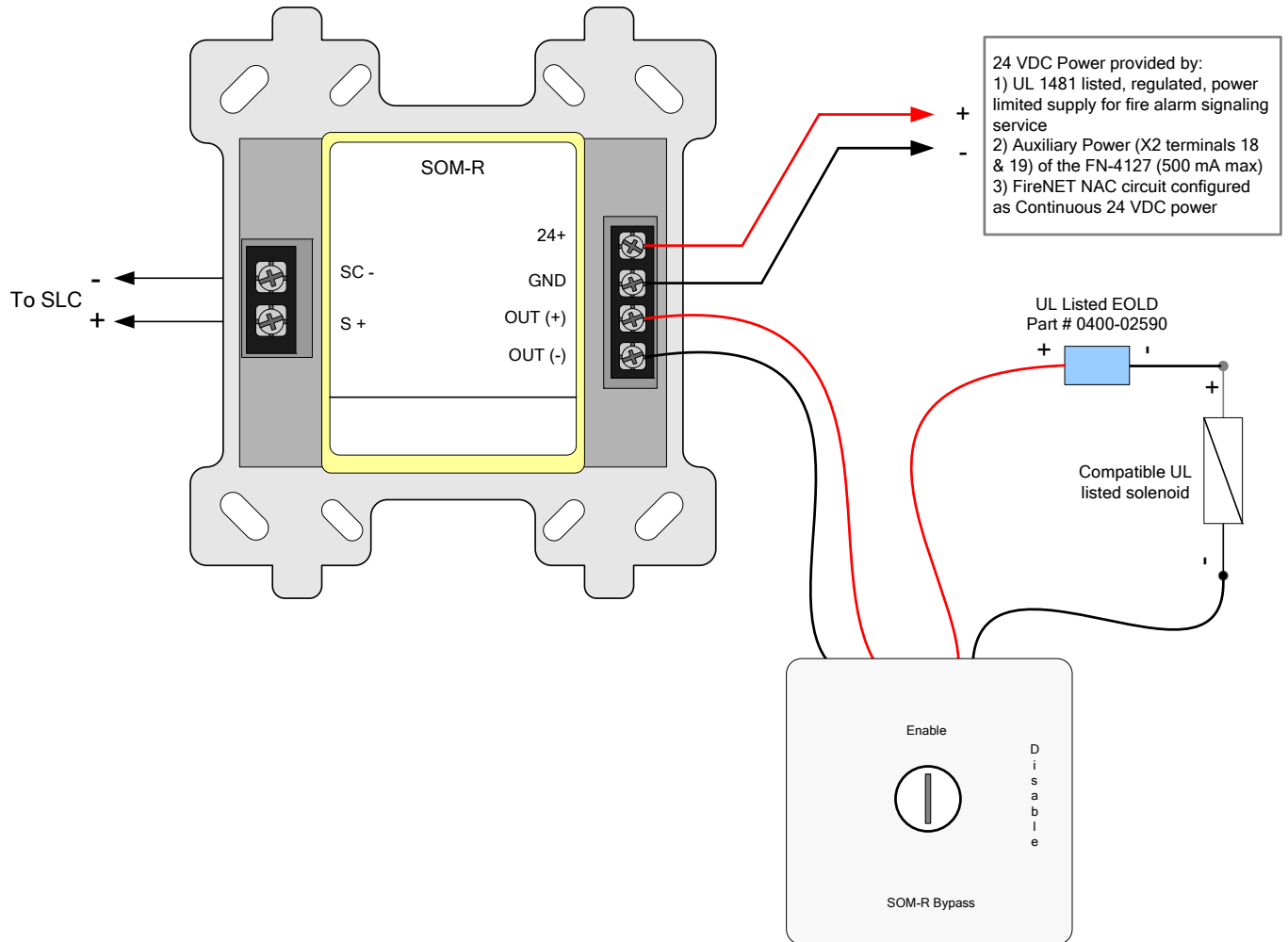

**Figure 5.13.1 SOM-R Supervised Output Module Detail**

6. Connect the output terminals on the keyswitch disable module to the solenoid. Ensure that the EOLD is properly connected to the circuit as shown in Figure 5.13.1 above.

### **Operation of the SOM-R**

The SOM-R is designed for use with single interlock preaction sprinkler systems. When the FireNET control panel detects a fire alarm condition from a single initiating point, the SOM-R will be activated, allowing water to flow into the sprinkler piping. Water is not discharged from a sprinkler head until increased temperature from the fire activates the sprinkler head.

Output delays are not applied to the activation of the SOM-R. The SOM-R output is activated immediately upon detection of a fire condition by the FireNET control panel.

**Important!** For proper operation, program the SOM-R Output Attributes as follows:

- Gen Alarm Mode = YES
- Silenceable = NO
- Emergency = NO
- Pre Alarm = NO
- Trouble = NO
- Pattern = CONTINUOUS
- Edit Location Text = SOMR

Program the FRCME attributes as follows:

- Set Input Type = GEN PURPOSE N/C EOL
- Set Input Action = SUPERVISORY
- Set Input Latch = NO
- Set Input Delay = 0s
- Edit Location Text = SOMR IS DISABLED

Other settings may be assigned as needed.

**Failure to follow these programming instructions may result in incorrect operation of the SOM-R module!**

**NOTE:** The location text will need to be programmed to state “**SOMR PREACTION DISCHARGE**” for all initiating devices, which activates the SOM-R module.

**Alarm Verification may not be used with the SOM-R.**

**NOTE:** Only one solenoid may be connected to the SOM-R. **DO NOT CONNECT MULTIPLE SOLENOIDS TO THE SOM-R OUTPUT CIRCUIT!**

To Disable the SOM-R:

Move the keyswitch to the “SOM-R Disabled” position.

To Enable the SOM-R:

Return the keyswitch to the “SOM-R Enabled” position.

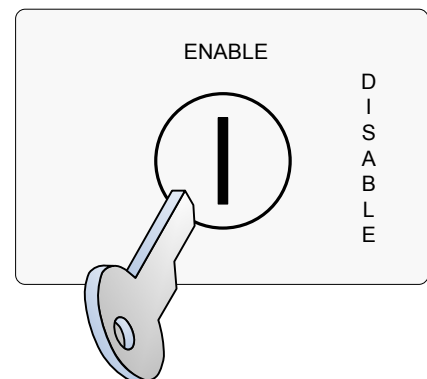

**NOTE: DO NOT DISABLE THE SOM-R OR KEYSWITCH MODULE BY USING THE DISABLEMENTS MENU ON THE FIRENET CONTROL PANEL!**

<b>Solenoid Compatibility List</b>			
<b>Manufacturer</b>	<b>Model Number</b>	<b>Standby Current (Amps)</b>	<b>Alarm Current</b>
ASCO	8210G207	0mA	44mA
Parker/Skinner	73218BN4UNLVNOC111C2	0mA	42mA

Maintenance: A maintenance agreement should be arranged through the local manufacturer's representative and maintenance should be performed annually by authorized personnel only. To keep a preaction system in excellent working order, ongoing maintenance is required per the manufacturer's recommendations and UL and NFPA standards. At a minimum the requirements of Chapter 13 of NFPA 25 (2010) shall be followed.

Test Weekly: The preaction system should be tested weekly to make sure SOM-R, FRCME and SOM-R-DS (Bypass Keyswitch) are working properly. The most common cause of an alarm system not functioning when a fire occurs is inadequate maintenance.

## 5.14 CZM Conventional Zone Module

The Conventional Zone Module (CZM) connects to the Signal Line Circuit (SLC). The module allows the analog panel to interface with and monitor conventional devices such as pull stations and two-wire smoke detectors. The CZM is typically used in retrofit situations where pre-existing conventional zones are removed from a conventional system and then connected to the analog panel for discrete monitoring of that zone. All conventional devices connected to a single CZM are reported as a single input. Status conditions are reported as normal, open or alarm. It supervises the external power supply as well as the entire zone of devices. Refer to the installation instructions included with the CZM for more detailed wiring and installation instructions.

NFPA STYLE B WIRING DIAGRAM

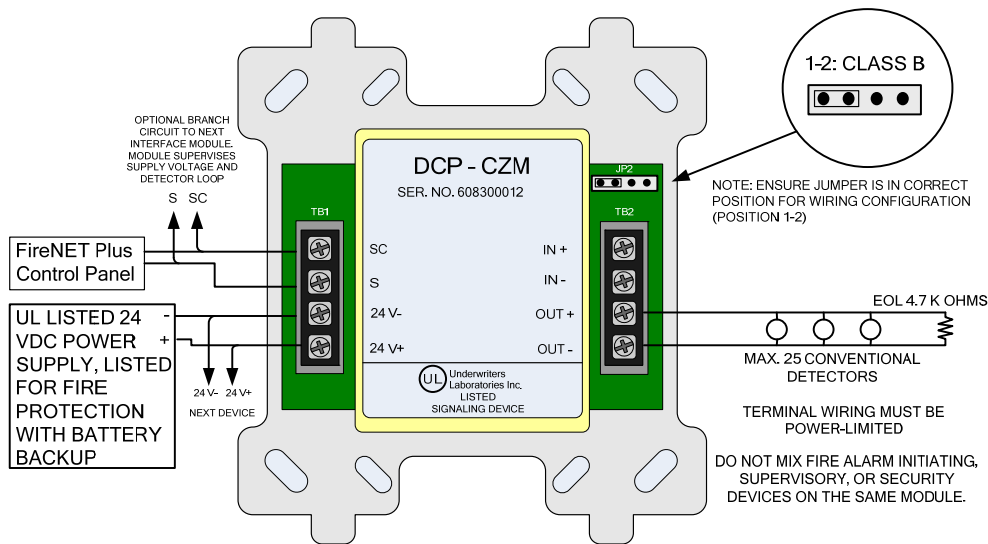

Figure 5.14.1 CZM Conventional Zone Module, Style B

NFPA STYLE D WIRING DIAGRAM

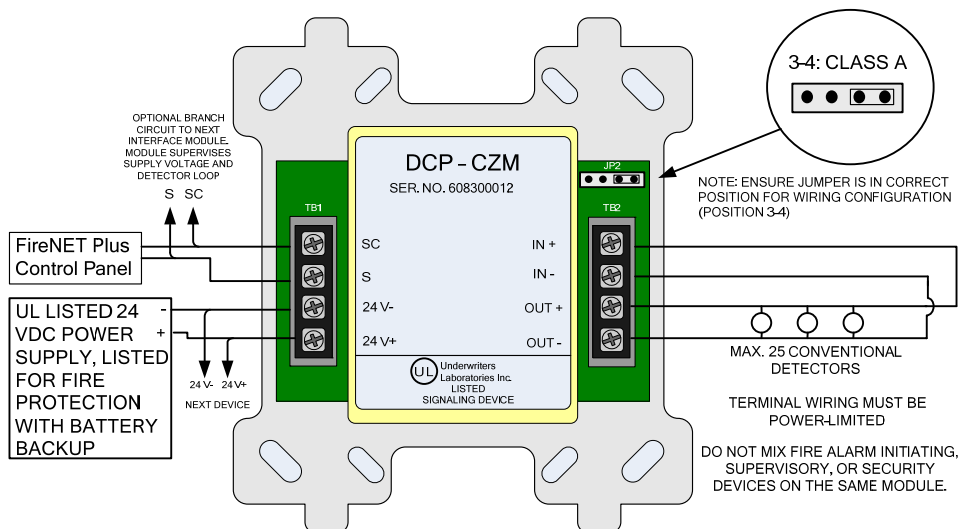

Figure 5.14.2 CZM Conventional Zone Module, Style D

## 5.15 DIMM Dual Input Monitor Module

The Hochiki DIMM Dual Input Monitor Module is designed to work with pull stations, water flow switches, and other applications requiring the monitoring of dry contact alarm initiating devices. The DIMM can monitor two independent inputs with discrete reporting, yet the module only requires a single address on the SLC Loop. A typical example would be for use with a waterflow and tamper application. One input would be connected to the waterflow switch for a fire alarm condition. The second input would be connected to the tamper switch for a supervisory condition. A single DIMM module would be used instead of two single input modules such as the FRCME. The DIMM inputs operate in a similar fashion to the FRCME input. Refer to the installation instructions included with the DIMM for more detailed wiring and installation instructions.

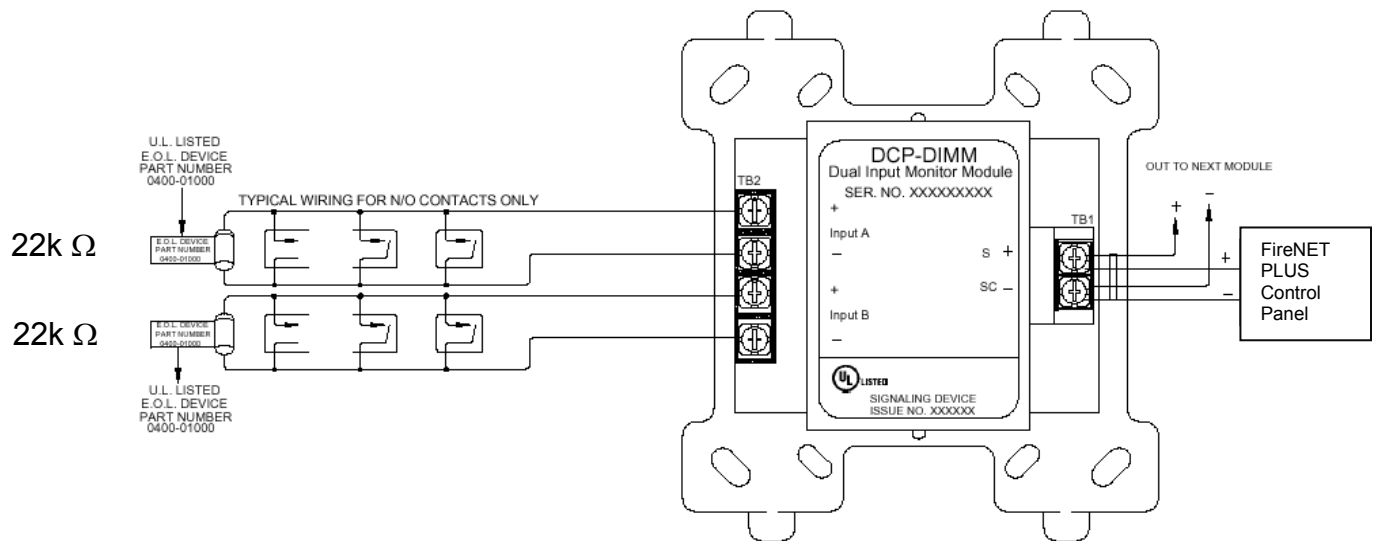

Figure 5.15 DIMM Dual Input Monitor Module Connections

## 5.16 SCI Short Circuit Isolator Module

The SCI short circuit isolator module is designed to help maintain partial SLC loop operation in the event that the SLC loop becomes shorted, positive to negative. In the event of an SLC loop short circuit the SLC loop is typically inoperative. By installing SCI modules throughout the SLC loop only a portion of the loop will be inoperative in the case of an SLC short circuit. When SCI modules are installed adjacent to every device for true Style 7 (see Section 5.16.1), no devices are lost from a single short on the SLC loop.

Connect the SCI module to the FireNET Plus control panel as shown in Figure 5.16.1. Refer to the installation instructions included with each SCI for more detailed wiring and installation instructions.

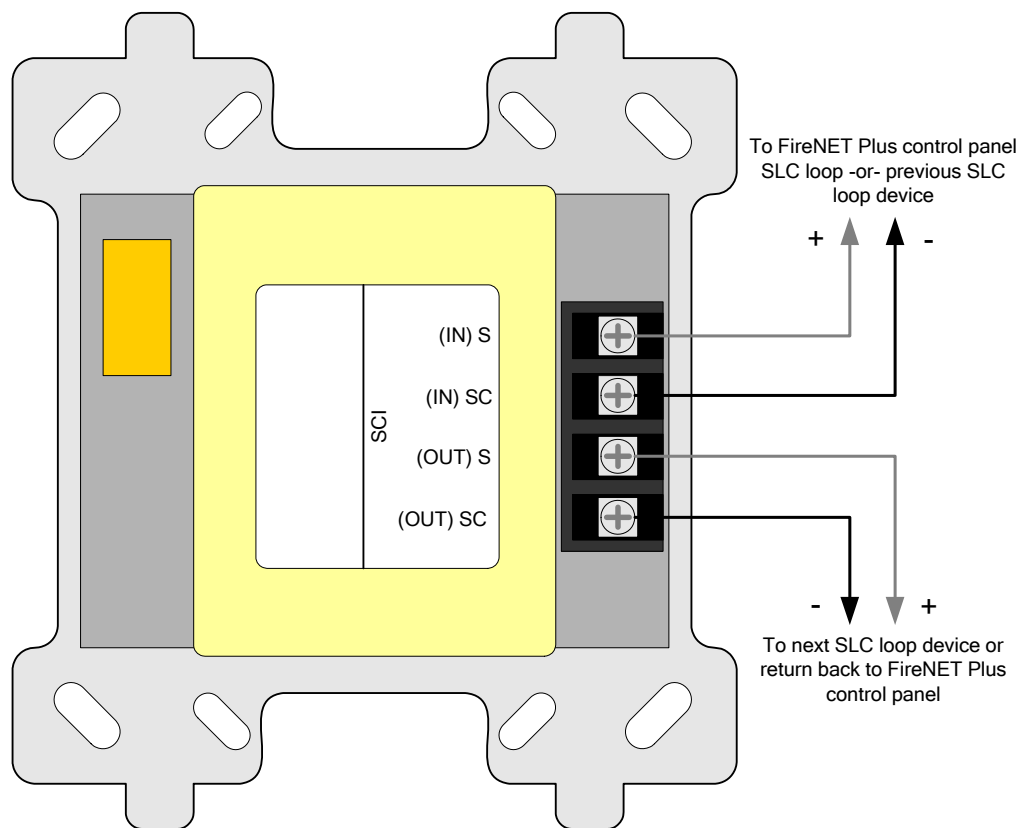

Figure 5.16.1 Short Circuit Isolator Module Connections

## 5.16.1 Class A Operation

The SCI should be located within 5 feet of the FireNET Plus control panel on both the outgoing and incoming SLC loop legs. In addition an SCI should be located between every SLC loop detector and module as shown in figure 5.15.2 and is required for NFPA 72 Class A Style 7 compliance. For Class A Style 6 compliance the SCI modules may be located at strategic locations based on the installer's or system designer's discretion.

In the event of a short circuit on the SLC loop the 2 SCI modules adjacent to the short (closest SCI on the left and the right of the short) will activate and its LED will turn on. All the devices between the two SCI modules will be isolated and inoperative. All other devices on that SLC loop will remain operational. The FireNET Plus control panel will indicate a trouble condition. When installing SCI modules for true Style 7 compliance, the SCI modules must be installed in a "closed nipple" fashion (see Figure 5.15.2). By using this method, no devices are lost from a single short on the SLC Loop.

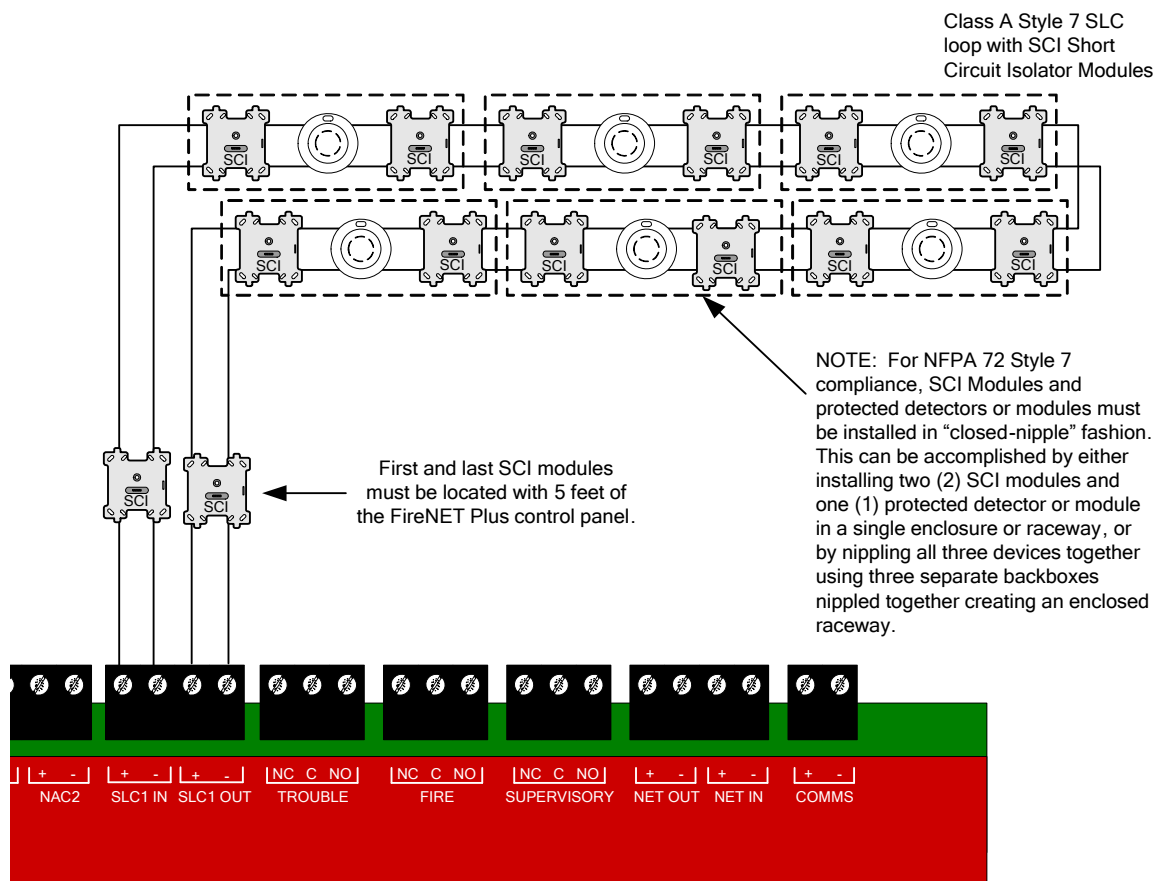

Figure 5.15.2 Style 7 SLC Circuit Example

## 5.16.2 Class B Operation

The SCI modules may be strategically located based on the installer or designer's discretion. Typically they are located at the beginning of each branch of the SLC loop as indicated in figure 5.15.3.

In the event of a short circuit on the SLC loop, the closest SCI to the short circuit will activate and its LED will turn on. All devices following the SCI module will be isolated and inoperative. All devices preceding the SCI module will remain operational.

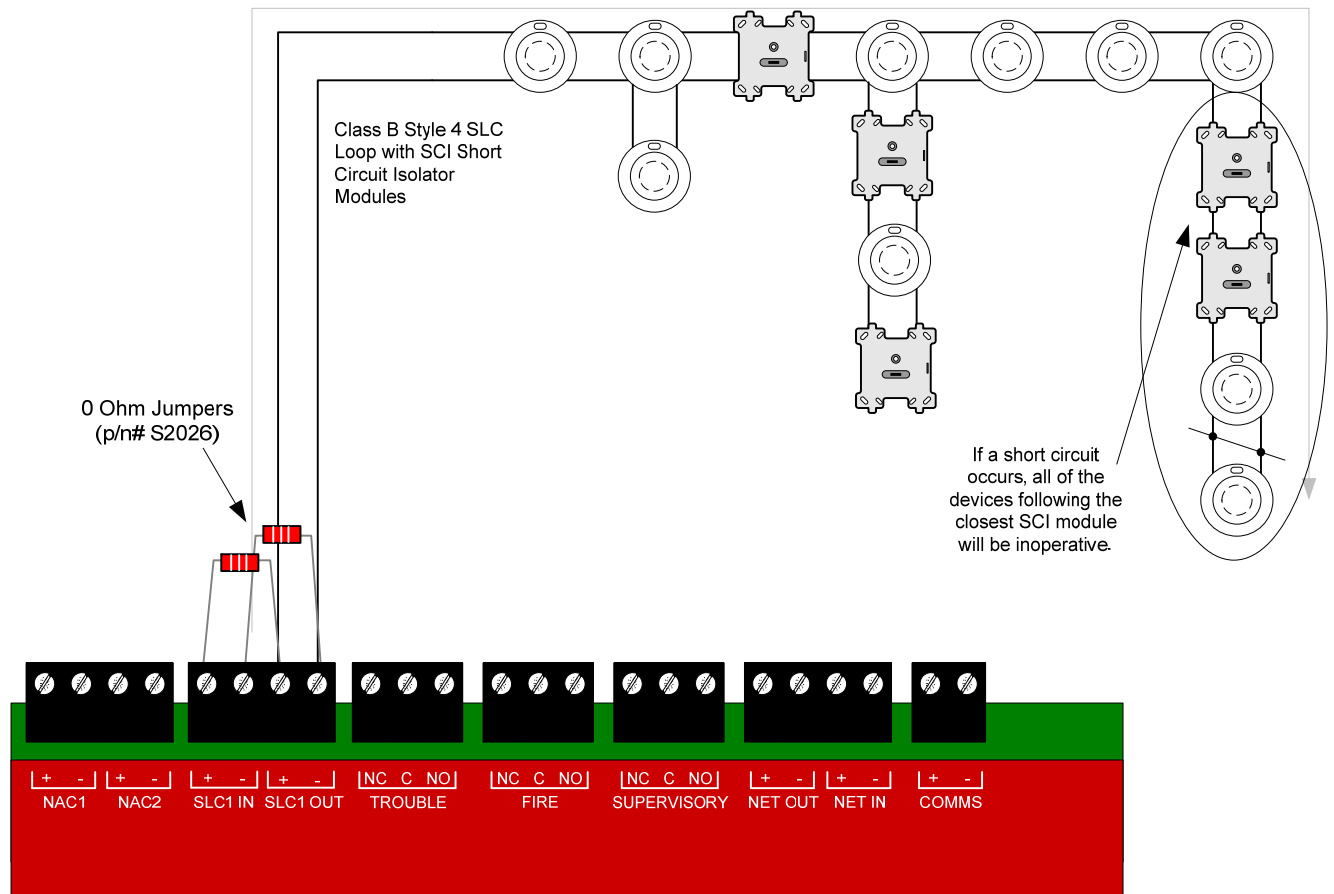

Figure 5.15.3 Class B Operation of the SCI Module



## 5.17 ASB & ASBL Analog Sounder Base

The Analog Sounder Base (ASB & ASBL) connects to the SLC Loop and requires 24VDC aux power to operate. The ASB (ASBL) contains an addressable sounder that is controlled by the control panel. The ASB derives its address from the Host detector (ALK, ALN, ALG, AIE, ATG, ATJ, ACA, ACB, ACC, ACD) upon power up. The address is the detector address + 127. See section 5.4 for additional details. The addressable sounder is independently controlled by the control panel, and does not have to follow the detector status to activate.

Refer to the installation instructions included with the ASB for more detailed installation and wiring instructions.

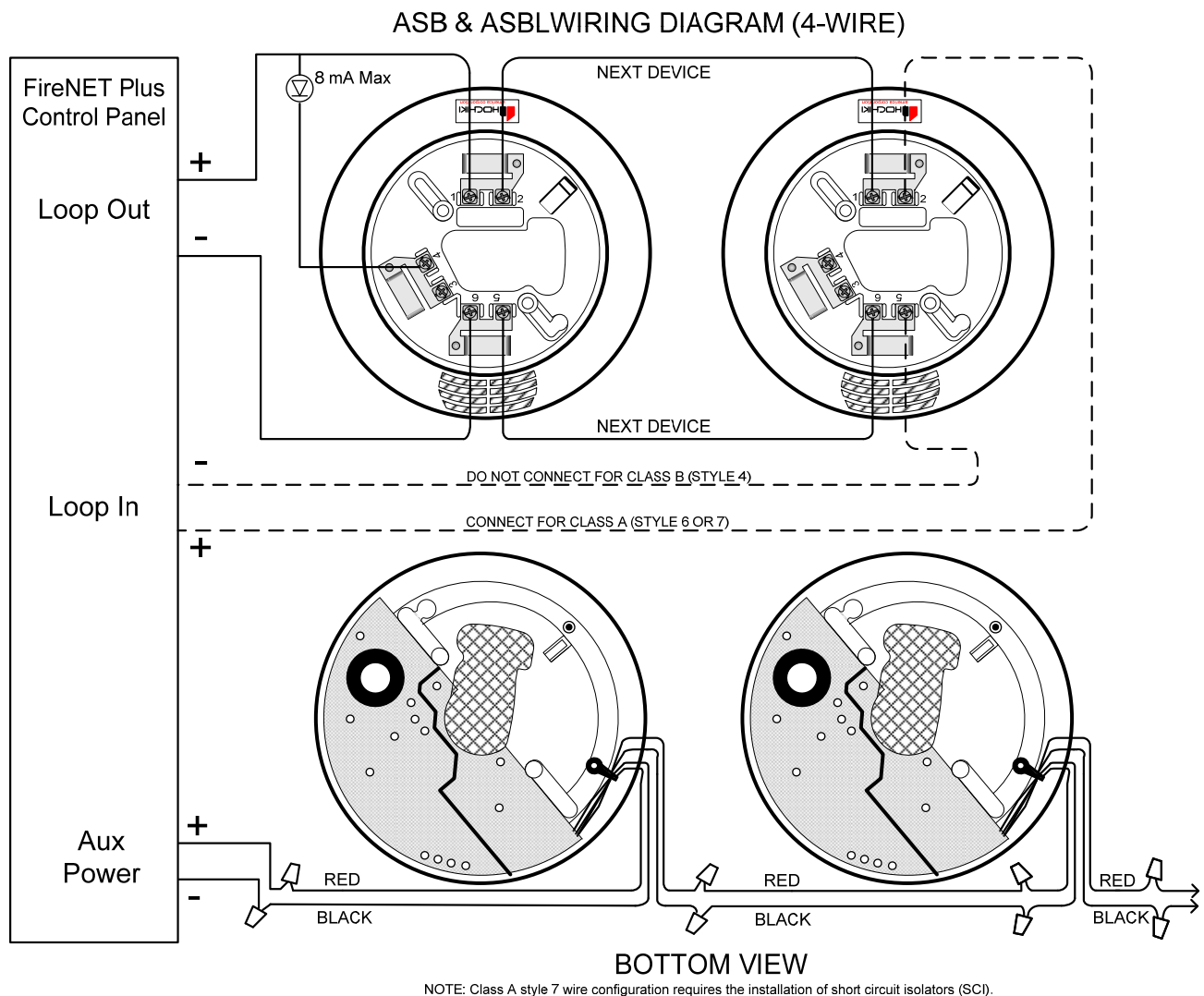

**Figure 5.16 ASB & ASBL Analog Sounder Base Connections**

## 5.18 AMS Addressable Manual Pull-Station

The AMS Addressable Manual Pull-Station is an integrated device that includes an input module and a manual pull-station in a single package.

The AMS is designed to be directly connected to the FireNET Plus control panel SLC loop.

The AMS must be programmed with a unique address from 1 – 127. Each AMS will report individually to the panel based on its unique address. Please refer to Section 5.4 of this manual for instructions on programming an address into the AMS device.

Connect the AMS to the FireNET Plus control panel as shown in Figure 5.17.1. Refer to the installation instructions included with the AMS device for more detailed installation and wiring instructions.

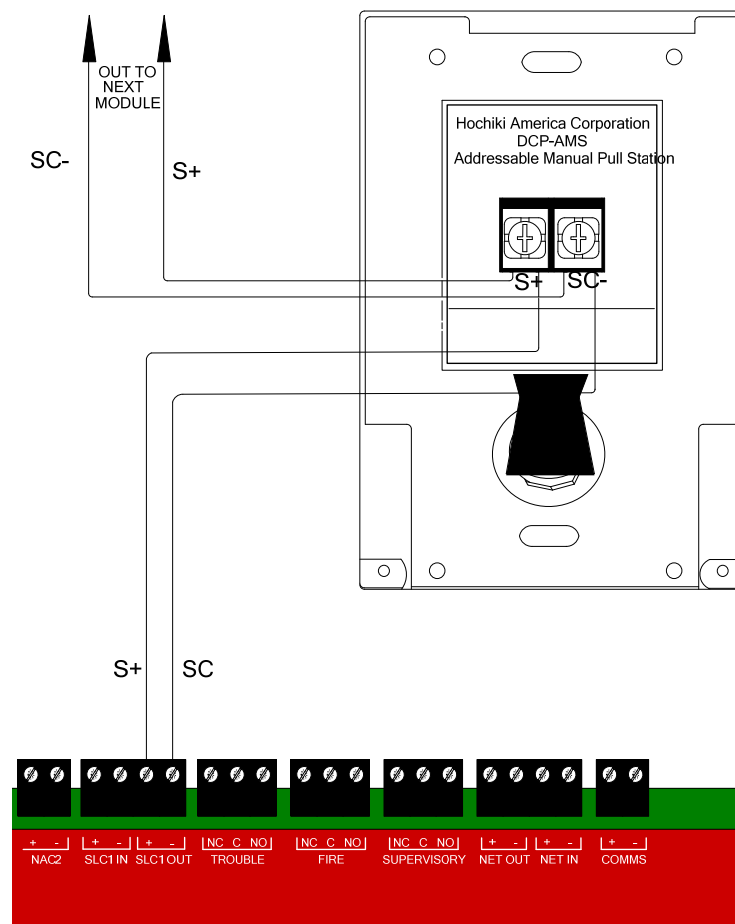

Figure 5.17.1 AMS Addressable Manual Pull Station Wiring Detail

## Section 6 - Network Connections

---

### **6.1 Compatible Network Devices**

---

The following Hochiki America Corp. network devices are listed as compatible with the FireNET Plus analog addressable fire alarm system.

#### **Network Interface Card**

- FN-4127-NIC

This section covers the installation of the FN-4127-NIC. For proper operation the control panel must be programmed to operate with this device. Please refer to Section 8 of this manual for more information on programming the FireNET Plus control panel.

The FireNET system enables information to be transmitted between control panels using a secure network connection. Up to sixty-four control panels (nodes) may be connected together and the system can be configured such that selected information can be displayed or acted upon at each panel.

### 6.1.1 FN-4127-NIC Network Interface Card

To enable control panels to be connected together as a network, a network card must be installed in each panel. This card connects to the FireNET Plus on the rear of the main control board and is held in position by two M3 screws. If an FNP-1127-SLC expander card has been installed, the network card must be mounted on top of the FNP-1127-SLC expander.

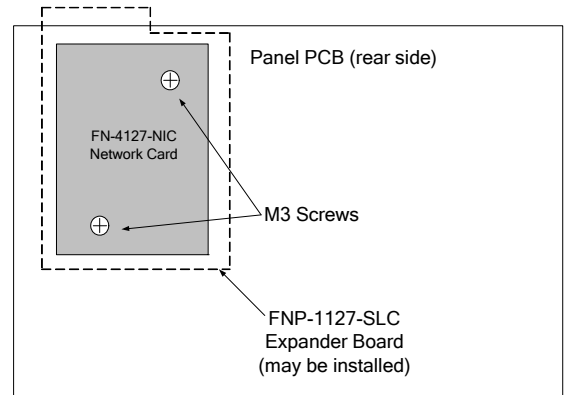

To install a network card, the AC and battery power must first be switched off. Next, the display panel must be opened to expose the back of the circuit board. The network card can then be plugged into the two connectors on the top left of the control board PCB (or plugged into the connectors on the FNP-1127-SLC card, if installed). The network card must then be secured in position with the M3 screws.

### OBSERVE STATIC PRECAUTIONS WHEN HANDLING CIRCUIT BOARDS!

Each network node must be allocated a unique network address. This is done by setting the DIP switches on the network card to the required binary number as shown above. It is important that each node has a different address for correct operation so care must be taken to set and record the network card address for each panel. Always set the address on the DIP switches with power to the panel **switched off**.

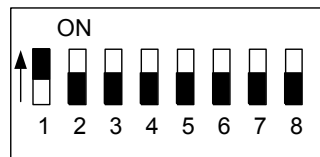

This switch setting shows address number one. Switch position up selects the binary digit, so a switch with 1,2 and 3 up would represent address number 7.

(The black part shows the switch actuator)

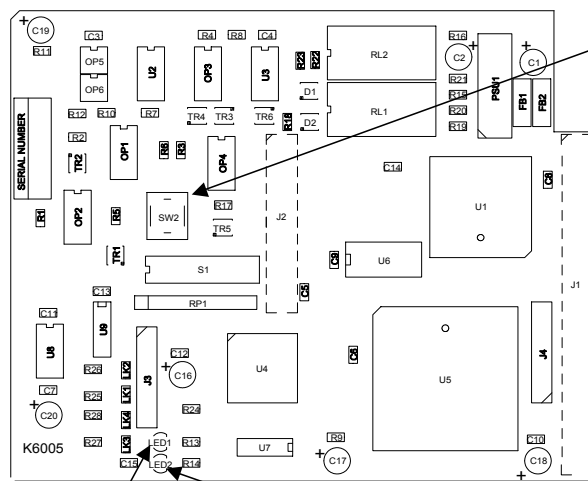

LED1-GREEN = OUTGOING CONNECTION OK      LED2-RED = INCOMING CONNECTION OK

This switch setting shows address number one. Switch position up selects the binary digit, so a switch with 1,2 and 3 up would represent address number 7.

The network card has a green and a red LED indicator to show the status of the incoming and outgoing communications. Under normal circumstances, both LEDs will be lit, indicating that the card is communicating properly. If one or both of the LEDs are not lit then the connection to neighboring panels is not functioning properly.

### 6.1.1.1 Cable Length

The FireNET Plus network communications protocol has been designed to be extremely tolerant to interference and data corruption; however as with any system, limitations must be set to guarantee correct operation. The specified transmission distance limit for the communications method used is 4000 ft. (1200m) and because the data is re-transmitted at each network card, in theory, there can be 4000 ft. (1200m) between each card if required. The minimum cable size for the FireNET Plus network is #20 AWG. The network communications uses RS485 technology.

Using the above cable distances however, does not take into account the failure of a network card to communicate with the system through total power failure or a card trouble. In this situation, the network card would disconnect itself from the network and connect the network cable such that it bypasses the card in question. This means that the total cable length between the cards either side of the disconnected one could be 8000 ft. (2400m), which is outside of the specification for the communications method used (RS485). This trouble scenario could clearly be extended to more network cards and this would add 4000 ft. (1200m) of cable length in each case.

A sensible trouble tolerance limit must therefore be suggested to enable the performance of the system to be predicted. Because of the nature of the fire protection system, its design is biased towards inherent reliability and failure of a network card, although possible, is very unlikely. Fire control panels also have substantial back up power systems. Therefore, the likelihood of a total power failure under operational conditions is also extremely rare. A suggested tolerance level of one card failure is therefore recommended. To guarantee operation of the system with one card failure it is necessary to arrange the network so that a failure will not introduce more than 4000 ft. (1200m) of cable between the two cards, which would be connected together by the failure. This means that the total cable length between adjacent nodes should not be more than 4000 ft. (1200m). It is not important how the 4000 ft. (1200 meters) is made up i.e. it could be 350 ft. (100m) and 3650 ft. (1100m) or 2000ft. (600m) and 2000ft. (600m).

Using these general rules and the specified or equivalent cable types will provide a guaranteed performance of networks with plenty of tolerance.

### 6.1.1.2 Wiring Scheme

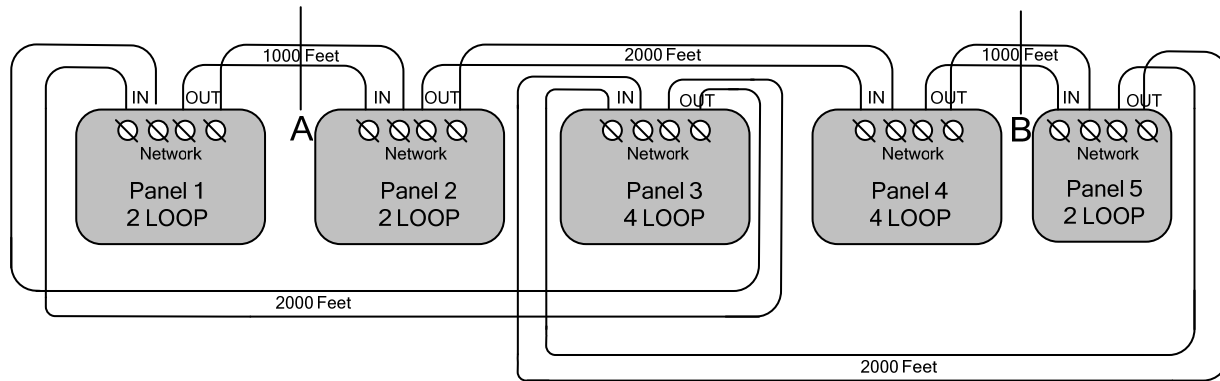

When designing or installing a network of FireNET Plus panels, always be aware of the following:

1. The panel network must be wired as a ring (Class A).
2. There should be no more than 4000 ft. (1200m) maximum cable length between two adjacent segments.
3. A short circuit at **Point A** will automatically disconnect the shorted section and announce a trouble condition at all panels but the entire network will continue communicating.
4. A short circuit at **Points A and B** will automatically disconnect both sections and announce a trouble at all panels. Communication will continue where a connection exists; in this case, a network will be maintained between panels 1, 3 and 5, while another network will be maintained between panels 2 and 4.
5. Open circuit troubles should allow the network to continue operating in the same way as short circuit troubles.
6. Network cabling should be standard RS485 type for up to 64 nodes.
7. The minimum cable size for the FireNET Plus network is #20 AWG.

### 6.1.1.3 Cable Type

The cable type used for the network connection should be suitable for RS-485 applications. Minimum wire size should be 20ga. twisted, shielded, stranded. RS485 communications cable is typically standard Class 2 communications cable. However, depending on the AHJ, FPL or FPLR cable may be required. Follow local jurisdictional and AHJ requirements. NFPA 70 national electric code compliance may be required for network cabling depending on local jurisdiction, AHJ, regulations, and/or codes.

### 6.1.1.4 Proper Shield Termination of the Network Cable

In many installations, interference from RFI, EMI or other noise sources can create problems. In order to reduce the effects of such noise, terminate the shield to the earth

ground terminal block in the main control panel. DO NOT ground the shield at both ends of the cable!

### 6.1.1.5 Connecting the network cable

All panels will have two cables connected to another panel or panels. If either of these is not connected a trouble condition will be displayed. The connection is polarity sensitive. The + and – from one panel must connect to the + and – of the next panel and so on. The temperature of the cable should not exceed 131 degrees F (55 C).

**NOTE:** It is important to ensure that the connection from the OUT+ from one panel connects to the IN+ terminal of the next and the OUT- from one panel connects to the IN- of the next panel and so on.

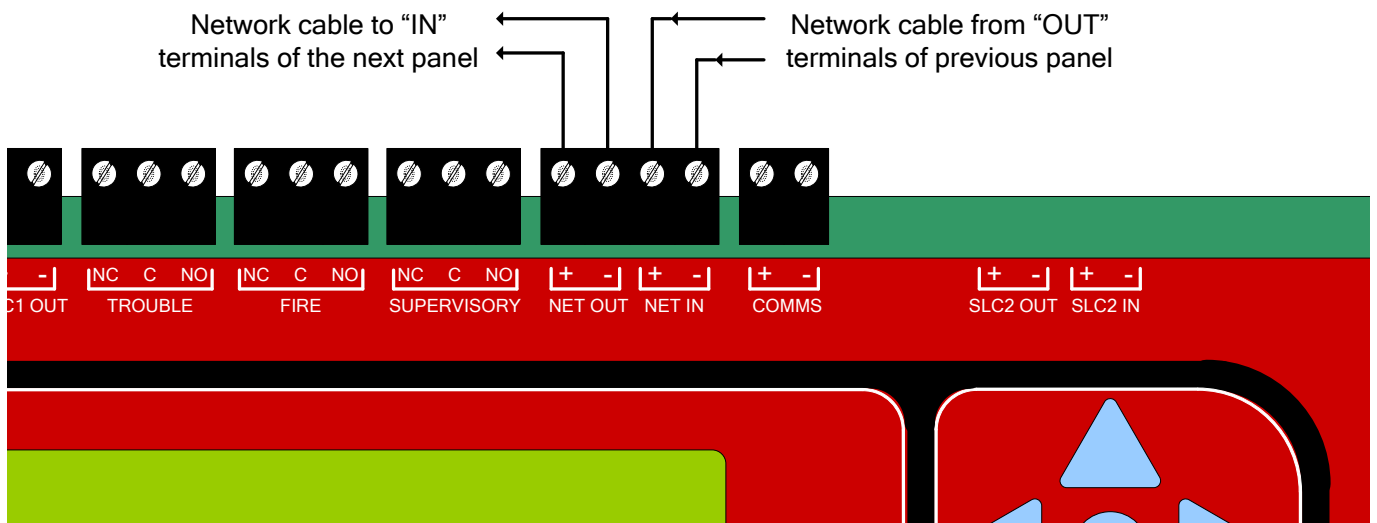
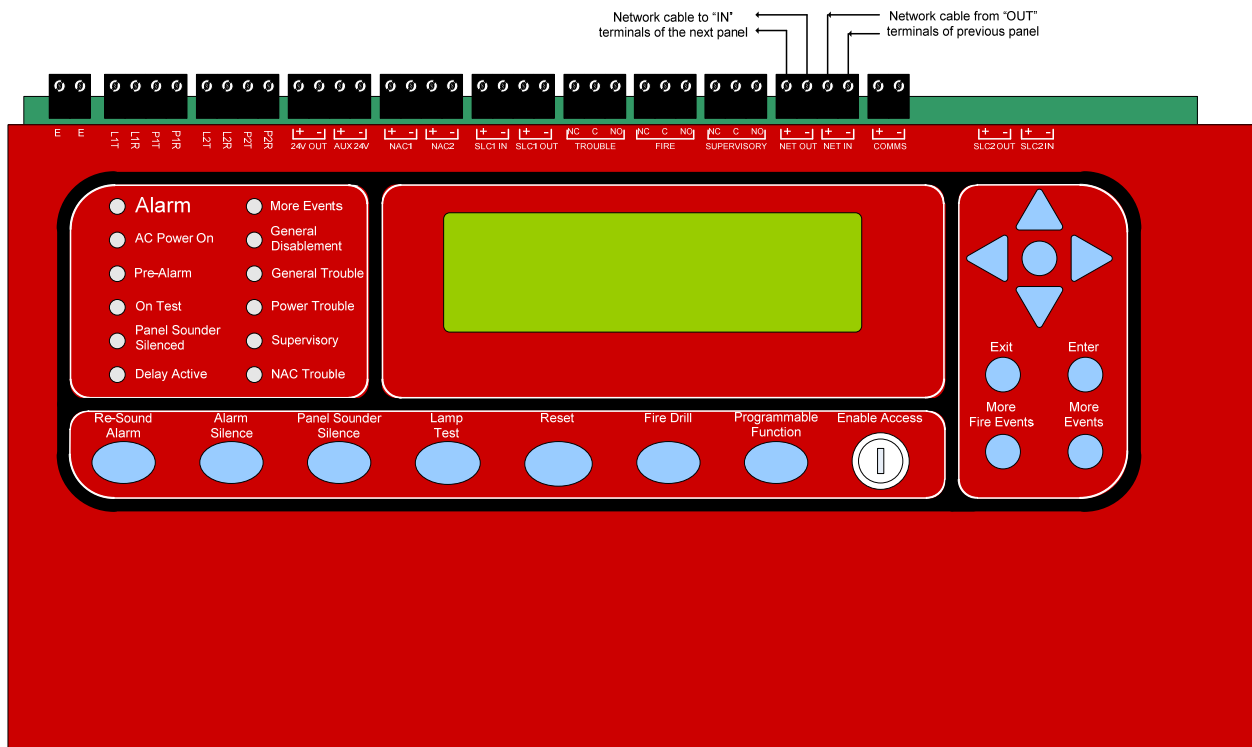



## Section 7 - Basic Front Panel Operations and Programming

### (Access Level 1, 2, and Real-Time Operation)

This section covers the basic user operations of the FireNET Plus and is intended to provide the casual user a basic understanding of how to complete common system operations. In addition to providing an overview of the front panel controls this section also includes instructions on how to:

- Perform a Lamp Test
- Silence the Panel Sounder
- View Multiple Fire Alarms on the Panel Display
- View Multiple System Events on the Panel Display
- Use the Menu Navigation Buttons
- Use the Help Function
- Silence an Alarm
- Resound an Alarm
- Reset an Alarm
- Initiate a Fire Drill
- Disable Portions of the System
- View the Status of System Devices
- Set system time

All of these operations are performed from the front panel keypad.

Please refer to the front panel photo in Figure 7.1 below while reading through this section.



Figure 7.1 Front Panel Controls

## 7.1 Operating Modes

---

This section provides a brief overview of Access Level 1, 2, and 3 operating modes. Access Level 1 and 2 operating modes are used in the basic system operations described in this chapter. Access Level 3 is typically used only by installation and service personnel and is explained in greater detail in Section 8 of this manual.

### 7.1.1 Access Level 1

When the FireNET Plus control panel is in **Normal Standby** condition only the green **AC Power On** LED will be lit, and the date and time displayed on the LCD display. **Normal Standby** is considered to be in Access Level 1. Some very basic operations can be done in Access Level 1 by simply pushing the corresponding button(s) on the front panel controls. For information on which basic user operations can be done from Access Level 1 see section 7.2.

### 7.1.2 Access Level 2

Many of the front panel controls and their operations require the user to enter a more secure operating mode called Access Level 2. This more secure operating mode prevents unauthorized individuals from operating the FireNET Plus fire alarm system. For information on which basic user operations are done from Access Level 2 see section 7.3.

### 7.1.3 Access Level 3

A higher security mode called Access Level 3 is also available to system administrators, installers, and service personnel to make critical changes to the system. For more information on Access Level 3 refer to Section 8 of this manual. None of the basic operations covered in this section require entry to Access Level 3 operating mode. Access Level 3 operating mode should be restricted to qualified installation and service personnel only.

## 7.2 Access Level 1 Operations

---

### 7.2.1 Performing a Lamp Test

Press the “**Lamp Test**” button on the front panel to illuminate all front panel LED indicators, LCD display, and validate correct operation. Release the button to conclude the test.

### 7.2.2 More Fire Events

The front panel display is capable of displaying the information for up to two different points that are in alarm condition. If more than two points are in an alarm condition simultaneously the front panel display will indicate how many additional alarms are active; this text can be seen in the bottom-left hand corner of the display. For example the display may indicate “**1 More Fire**”. In this case there is one additional point in fire alarm condition that is not currently shown on the display. By pressing the “**More Fire Events**” button, the user can display these additional alarms.

### 7.2.3 More Events

Similar to the “More Fire Events” button, the “**More Events**” button allows the user to display more non-fire alarm events if more than 1 event is active on the system at one time.

### 7.2.4 Menu Navigation (Up, Down, Left, Right Arrows, Enter / Exit Buttons)

These buttons are used to navigate the FireNET Plus menu structure. The arrow buttons (**up, right, down, left**) also represent the digits 1, 2, 3, and 4 respectively when entering codes for Access Level 2 or Access Level 3 modes.

### 7.2.5 Help (?)

The “**Help**” button offers additional information relating to the current status of the FireNET Plus control panel and provides assistance in basic operation of the system. Press and hold the “**Help**” button to display this additional information.

## 7.3 Access Level 2 Operations

---

The following operations can only be done after the panel is placed into Access Level 2 operating mode. To place the FireNET Plus into Access Level 2 follow these instructions:

### 7.3.1 Entering Access Level 2

1. Press any navigational arrow key to enable the panel.
2. Using the arrow keys enter the 5 digit code. Digit values are 1 - 4 only and correspond to the value on each arrow key. (Up = 1, Right = 2, Down = 3, Left = 4) The factory default for the Access Level 2 code is 22222.
3. Press the Enter key. The front panel graphic display will confirm you are in Access Level 2.
4. If there is no activity for 120 seconds on the front panel controls once the system is in Access Level 2 operating mode, the system will time out and revert back to Access Level 1 operating mode automatically.
5. You may also use the Enable Access keyswitch on the front of the panel to enter Access Level 2. Simply insert the key and turn it to the right. The panel display will confirm that you are in Access Level 2.

**NOTE:** The FireNET Plus panel will NOT time out to Level 1 when using the key. Be sure to return the key to the OFF position and remove it when not in use!

### 7.3.2 Silencing an Alarm

To silence an alarm condition place the panel into Access Level 2 operating mode as described in 7.3.1. Press the **“Alarm Silence”** button. The **“Alarm Silence”** button acknowledges any current alarm conditions and typically silences any audible and visual notification appliances such as horns and strobes. In some cases the system may be programmed so that the **“Alarm Silence”** button silences the audible notification appliances but allows the visual notification appliances such as strobes to remain flashing. Your system installer can inform you how your system is set up to operate. After an alarm has been silenced, the flashing fire LED's will go steady, and **“alarm silenced”** will display in the upper right corner of the LCD display.

### 7.3.3 Resounding an Alarm

To resound an alarm condition place the panel into Access Level 2 operating mode as described in 7.3.1. Press the **“Resound Alarm”** button. Pressing the **“Resound Alarm”** button will reactivate any audible or visual notification appliances that were previously silenced using the Alarm Silence operation.

### 7.3.4 Resetting an Alarm

Once a fire or other alarm condition has been verified and cleared it is necessary to reset the panel. To reset the FireNET Plus, place the panel into Access Level 2 operating mode as described in 7.3.1. Press the “Reset” button. All latched outputs such as relays used for elevator recall will return to their normal state.

Prior to resetting the panel it is necessary to clear the condition that caused the alarm. For example, if a manual pull station was activated to cause the alarm, that manual pull station must be physically reset in order to reset the panel. If you attempt to reset a panel that has an existing alarm condition that has not been cleared, the panel will go back into alarm immediately after trying to reset.

### 7.3.5 Initiating a Fire Drill

To initiate a fire drill, place the FireNET Plus panel into Access Level 2 operating mode as described in 7.3.1. Press the “Fire Drill” button to engage fire drill mode. The fire drill activates NAC and SOM indication circuits, but does not activate fire relays, R2M, programmable relays, etc. A subsequent press of the fire drill button will deactivate fire drill mode. Any actual fire alarms during a Fire Drill will automatically override fire drill mode.

### 7.3.6 Silence the Panel Sounder

Many system conditions such as system troubles will activate the sounder in the FireNET Plus control panel. The user can silence the panel sounder by pressing the “**Panel Sounder Silence**” button on the front panel. This silences only the panel sounder. Other audible outputs such as horns or strobes require a different operation to silence.

## 7.4 Advanced Access Level 2 Operations

---

### 7.4.1 Access Level 2 Main Menu

Once you have entered Access Level 2 operating mode you can view the Access Level 2 Main Menu, which gives the user the ability to perform additional system operational functions. To view the menu, enter Access Level 2, and then press any one of the navigational arrow keys.

ACCESS LEVEL 2 MAIN MENU
DISABLEMENTS
VIEW DEVICES
TEST ZONES
SET SYSTEM TIME
SENSOR MAINTENANCE EARLY WARNING
ACCESS LEVEL 3

**Figure 7.4 Main menu items at Access Level 2**

Once this menu is displayed you can scroll up or down using the navigational arrow keys to highlight each of the six menu options. A menu option is highlighted when a triangular arrow symbol appears to its left.

Each menu option may be selected by first highlighting it using the up/down arrow keys, then pressing the right arrow key to select. The six Access Level 2 Main Menu option functions are described in the following sections.

### 7.4.2 Disablements

The Disablements menu allows the user to disable individual points, circuits, zones, or loops on the FireNET Plus fire alarm system. This is typically done while the system is being serviced or tested or to temporarily remove a faulty system device. CAUTION: Any portion of the system that is disabled will not report an alarm condition.

All disablements have two options, timed or untimed. For disablements up to 24 hours in length the timed disablement option should be used. This will prompt the user to enter a disablement time in 30-minute increments from 30 minutes to 24 hours. Once the disablement begins the panel will countdown the selected disablement time. When the time expires the disablement is cancelled automatically.

Untimed disablements should be used only when it is necessary to disable a portion of the system for over 24 hours. Untimed disablements remain active until they are manually reset at the panel through the Access Level 2 Main Menu / Disablements command.

Once you select timed or untimed disablement you can choose to disable loops, zones, addresses, NAC, or I/O circuits through sub-menus to the Access Level 2 Main Menu / Disablements option.

As previously discussed highlighting the desired menu option and then pressing the right navigational arrow selects that option. Pressing the left navigational arrow at any time backs out of the current menu returning to the previous menu.

**Note:** The FireNET Plus fire alarm system will indicate a disabled condition any time there is an active disablement on the system, via LCD display text and the “point bypassed” LED on the front panel. Any item disabled is considered an off-normal condition and will generate a general trouble condition until the disabled item is returned to normal.

### 7.4.2.1 Disabling Loops

The Disable Loops sub-menu option to Disablements, allows you to disable an entire SLC loop with one command. The SLC loop may contain up to 127 analog detectors and addressable input and/or output modules, as well as up to 127 analog sounder bases. Disabling an entire SLC loop disables all inputs and outputs on the loop and should be used only in extreme cases such as a service related problem affecting all the devices on the SLC loop.

**WARNING:** Loop disablement does not electrically isolate the panel from the SLC loop wiring. The SLC loop should be disconnected from the panel before any diagnostic testing is performed.

### Disabling Zones

Each device on the system is assigned to a zone by the system installer. A zone may consist of one or many points. Disabling a zone disables all the points assigned to that zone.

### Disabling Addresses

Each SLC loop device on the system is assigned a unique address. In some cases an SLC loop device may have sub addresses as well. Using the Disable Address sub-menu command the user can individually disable any single address on the system.

### Disabling NAC Outputs

The disable Audible Device output sub-menu option allows the user to disable all of the local NAC, SOM, and ASB (ASBL) outputs on the system. This is typically done for periodic tests so the building occupants are not disturbed while activating each alarm device. When you choose this option all of the notification appliances connected to the panel notification appliance circuits and SOM modules are disabled, as well as any analog sounder bases.

## **Disable Panel I/O**

The Disable Panel I/O sub-menu option allows a user to disable an individual panel input or output. This includes individual notification appliance (NAC) circuits, on-board panel relays, and the programmable function button. This option applies only to on-board inputs and outputs – SLC loop devices must be disabled by using the Disable Addresses option.

## **View & Restore Disablements**

The View & Restore Disablements sub-menu option is used to quickly display any system disablements and optionally reset them to normal. Scroll to the View/Restore Disablements sub-menu option, press the right navigational arrow to select, and then follow the prompts on the panel display to view/reset any disablements on the system.

### **7.4.3 View Devices**

The View Devices menu option allows the user to view every SLC loop device. For each device the panel display will indicate the device type, zone, and location text. In addition, analog devices such as smoke and heat detectors will also be displayed with their current analog value. This analog value can be useful in determining if a smoke detector requires cleaning. Photoelectric detectors also display in terms of obscuration (%/ft) and the heat detectors in terms of temperature (F°).

For non-analog input devices the current status will be displayed as Off or On. For non-analog output devices the current status will be displayed as either Off or Activated. Service personnel who want to verify system devices and troubleshoot potential problems typically use the View Devices sub-menu option.

### **7.4.4 Test Zones**

The Test Zones sub-menu option is used by service personnel to quickly and easily perform periodic system tests. Please refer to the testing and troubleshooting section of this manual for a more detailed explanation. This feature is typically referred to as a “One Man Walk Test.”

### **7.4.5 Set System Time**

This sub-menu option is used to adjust the FireNET Plus internal clock. It is important to make sure the clock is accurate so that events logged in the event log are recorded with the correct time.

To set the system clock, select the Set System Time sub-menu option by highlighting it with the up/down arrow keys. Select it by pressing the right arrow key. The resulting menu allows you to individually set the Year, Month, Day, Hour, Minute, and Daylight Savings. Highlight



each option by using the up/down arrow keys. Press the right arrow key to select it. Use the up/down arrow keys to change the current values. Pressing the left arrow key in any menu backs you out to the previous menu.

#### **7.4.6 Sensor Maintenance Early Warning**

This option is used by service personnel to identify sensors that require cleaning or replacement.

## 7.5 Panel Operation

---

This section summarizes the operations described earlier in this section of the manual for handling Fire, CO, Trouble, and Supervisory conditions.

### 7.5.1 Fire Condition

In the event a device on the FireNET Plus fire alarm system activates in a fire alarm condition the following will happen:

- The Alarm LED indicator on the front panel will turn on and flash.
- Details of the device that caused the fire alarm condition will be given in the LCD status display on the front panel.
- If there are more than two fire conditions, press the “**More Fire Events**” button on the front panel to view the additional fire alarms.
- Audible and visual notification appliances (horn and strobes) will activate throughout the building.
- Output relays and circuits will operate performing fire alarm functions such as closing doors, recalling elevators, shutting down air handling equipment etc.
- The panel buzzer will be pulsing.

The operator actions required following a fire alarm condition are as follows:

- Silence the panel buzzer by entering access level 2 and pressing the “**Panel Sounder Silence**” button.
- Silence the notification appliances by entering Access Level 2 and pressing the “**Alarm Silence**” button. When the Fire condition is silenced, the fire LED indicator will change from flashing to steady and the LCD display will indicate “Alarm Silenced”.
- Resound the audible and visual notification appliances if necessary by entering Access Level 2 and pressing the “**Resound Alarm**” button.
- Once the fire department has cleared the building, physically reset any devices such as manual pull stations that require a manual reset.
- Reset the FireNET Plus fire alarm control panel by entering Access Level 2 and pressing the “**Reset**” button.

## 7.5.2 CO Condition

In the event of a CO Alarm, the red Alarm lamp and the appropriate Fire Zone Indicator flash (if connected). Details of the CO activation (address and location text) display on the front-panel.

CO warning NACs sound throughout the programmed area. The panel buzzer pulses, but can be silenced by pressing the Silence Buzzer button.

To silence CO NACs, press any of the menu navigation buttons and enter the Access 2 password then press the Enter button. Panel controls will be enabled and will remain enabled for one minute after pressing the last key. Pressing the Alarm Silence button will silence the NACs. The NACs can be started again by pressing the Re-Sound Alarm button. The system can be reset by pressing the Reset button.

Press the More Events button on the front-panel to display the status of more than two fire events.

### **Usage of Carbon Monoxide Detection & Standby Battery Requirements**

When an installation is Local Service & Carbon Monoxide detection is installed, after the 5 min of carbon monoxide alarm, the maximum carbon monoxide alarm load shall continue to be applied for a period of not be less than 12 hours. A Power Supply UL listed for Fire Service must power the CO sounding devices. The 12 hr period may be eliminated when the system is monitored by a supervising station with emergency response. NFPA 720 shall be the guideline for Installation of Carbon Monoxide (CO) Detection and Warning Equipment.

## 7.5.3 Trouble Condition

Trouble conditions occur when problems with the FireNET Plus fire alarm system components and wiring are detected.

When the fire alarm control panel senses a trouble condition, the following will occur.

- The General Trouble LED will illuminate on the front panel.
- Other LED's indicating the nature of the trouble may also illuminate.
- The trouble relay contact in the control panel will activate
- Details of the trouble condition will be shown on the LCD status display on the front panel.
- If there is more than one trouble event press the "**More Events**" button to view them in the LCD status display on the front panel.
- The panel buzzer will sound.

The operations required following a trouble condition are as follows:

- Silence the panel buzzer by entering access level 2 and pressing the “**Panel Sounder Silence**” button.
- Note the LCD status display and any messages that may appear so these can be relayed to service personnel.
- Investigate the cause of the trouble. It may be as simple as a detector that was inadvertently removed.
- If the trouble condition cannot be resolved, contact your service company.

There is no need to reset trouble conditions. They are non-latching and reset themselves after the trouble condition is corrected.

**NOTE:** Loop Open/Short troubles are latching and require a panel reset to clear.

#### 7.5.4 Supervisory Condition

A supervisory condition is detected when a portion of a building system that controls the spread of fire or smoke is disabled. This is most commonly a fire sprinkler valve that is turned off for maintenance purposes.

When the FireNET Plus fire alarm control panel senses a supervisory condition the following will occur:

- The Supervisory LED will illuminate on the front panel.
- The supervisory relay contact in the control panel will activate.
- Details of the supervisory condition will be shown on the LCD status display on the front panel.
- The panel buzzer will sound.

The operations required following a supervisory condition are as follows:

- Silence the panel buzzer by entering access level 2 and pressing the “**Panel Sounder Silence**” button.
- Note the LCD status display and any messages that may appear so these can be relayed to service personnel, fire department, and/or central station.
- Investigate the cause of the supervisory conditions.

- If the supervisory condition cannot be resolved, contact your service company.
- Once the supervisory condition has been cleared, reset the FireNET Plus fire alarm control panel by entering Access Level 2 and pressing the “Reset” button.

### 7.5.5 Pre-Alarm Condition

A Pre-Alarm condition occurs when an analog sensor reaches its pre-alarm threshold, or when an input whose type is set to pre-alarm activates. This condition typically occurs as the sensor approaches its fire point.

When the FireNET Plus fire alarm control panel senses a pre-alarm condition, the following will occur:

- The Pre-Alarm LED will illuminate on the front panel.
- Details of the pre-alarm condition will be shown on the LCD status display on the front panel.
- If there are multiple events, press the “More Events” button to view them in the LCD status display on the front panel.
- The panel buzzer will sound.

The operations required following a Pre-Alarm condition are as follows:

- Silence the panel buzzer by entering access level 2 and pressing the “**Panel Sounder Silence**” button.
- Note the LCD status display and any messages that may appear so these can be relayed to service personnel.
- Investigate the cause of the Pre-Alarm, such as a significant presence of smoke, heat, or an actual fire starting.
- If the Pre-Alarm condition cannot be resolved, contact your service company.
- Once the Pre-Alarm condition has been cleared, reset the FireNET Plus fire alarm control panel by entering access level 2 and pressing the “reset” button.

## ***7.6 DACT Operation and Event Reporting Codes (FNP-1127D only)***

---

The FireNET Plus FNP-1127D contains an integrated DACT. This section provides details about the operation of the DACT.

### **7.61 Compatible Receivers (DACRs)**

The Hochiki America FireNET Plus is compatible with the following Digital Alarm Communicator Receivers (DACRs):

Silent Knight 9500	Contact ID and SIA formats
DSC System 3	Contact ID and SIA formats
Bosch D6600	Contact ID and SIA formats
Sur-Gard MLR-2E	Contact ID and SIA formats

### **7.62 Phone Line and Phone Number Selection**

The FireNET Plus DACT can be configured with up to four account numbers and four phone numbers. Each phone number corresponds to an account (phone number 1 is used with Account 1; phone number 2 is used with Account 2, etc). This allows for programming of backup and duplicate reporting configurations.

Events are communicated to each account in order and by priority beginning with Account 1. The communicator will begin the dialing sequence using phone line 1, unless phone line 1 has failed. If the communicator cannot report events successfully using phone line 1, it automatically switches to phone line 2.

Account 1 and account 2 are used together for primary and backup reporting. If duplicate reporting is needed, account 3 may be used, with account 4 serving as its backup. Table 7.62 shows how the accounts and phone lines are selected when reporting an event (both phone lines in normal working condition).

Attempt #	Account*	Phone Line
1	1	1
2	1	1
3	1	1
4	1	2
5	1	2
Communication Fail Acct 1		
6	2	2
7	2	1
8	2	1
9	2	2
10	2	2
Communication Fail Acct 2		

Table 7.62 – Communicator Account and Phone Line Selection

\*Note that the same sequence applies when accounts 3 and 4 are used.

Since the communicator selects the phone line to be used, both lines must use the same dialing sequence. If one phone line requires that a “9” be dialed, it cannot be used with a second line that does not require a “9”.

**NOTE:** *Ground Start phone lines must not be used.*

**NOTE:** *Call Forwarding must not be used.*

**7.6.2.1 Test Report:** The test report is sent using alternating phone lines once every 24 hours. All attempts to communicate the test report will be made on one phone line, even if that line is not working. The next test report is sent using the other phone line. This complies with UL and NFPA requirements for digital alarm communicators.

**NOTE:** *If the central station only receives every other test report (i.e. every other day), this is an indication that the communicator is unable to report using one of the phone lines. Investigate and correct the cause of this condition immediately.*

### **7.6.3 Phone Line Supervision**

The FireNET Plus supervises both telephone lines for the presence of normal line voltage. Each line is checked every 10 seconds. If trouble with a phone line is detected, the FireNET display will indicate the trouble condition. The phone line failure can be communicated to the monitoring station using the other phone line, unless it has also failed.

Normal phone line voltage is approximately 48 VDC. The panel will detect a trouble condition when the phone line voltage falls below 4 VDC.

**NOTE:** *Since the FireNET Plus samples voltage to test the telephone lines, it cannot recognize a non-working phone line that has normal voltage present.*

**NOTE:** *The FireNET Plus does not supervise the telephone lines while it is communicating.*

## 7.6.4 Report Groups

The FireNET Plus has five report groups that can be selected to maximize the reporting options. Each group includes specific types of events that will be reported. The report groups are selected by account, with account 2 and 4 also having a selection for backup reporting. The report groups and events associated with them are shown below:

### Alarms –

- Fire Alarm
- CO Alarm
- Waterflow Alarm
- Fire Drill

### Alarm Restore –

- Fire Alarm Restore
- Waterflow Alarm Restore
- Fire Drill Restore

### Supervisory, Trouble, Enable/Disable –

- Supervisory (Activation and Restore)
- All Trouble Conditions (Activation and Restore)
- Pre-Alarm (Activation and Restore)
- Auxiliary (Activation and Restore)
- Smoke Detector Maintenance Trouble (Activation and Restore)
- Disable and Enable Events
- Loop Explorer Programming Event (local and remote)

### Service / Test –

- “Test Zones”
- Device Tested
- Test Report

### System Reset –

- Alarm Silence Event
- Reset Event

### Backup Report (Account 2 and 4 Only)

- Account 2 and 4 can be selected to report to the associated phone number as a *backup* of the primary account. For this feature, account 1 is considered the primary account, with account 2 being its backup. Account 3 serves as a second primary, or duplicate account, with account 4 being its backup.

If communication is not established to the primary account after the first five attempts, the backup account will be used. Please see section 7.2 for additional details.



By default, all report groups are selected for each account. If it is necessary to change the groups selected for a particular account you must use the Loop Explorer software programming tool.

## 7.6.5 Communication Failure

If all attempts to communicate to an account fail, the FireNET Plus will display a “Comms Fail” trouble condition, along with the number of the account that failed (1 – 4). The original event will be removed from the report queue. If there are additional events to be reported the panel will attempt to report them, along with a communication failure event. The panel will remain in a “Comms Fail” trouble condition, but the FireNET Plus will attempt to report any new events while in this state.

To clear the “Comms Fail” trouble from the panel display, press the panel Reset button. This action will also generate a communication restore event that will be reported to the monitoring station.

## 7.6.6 AC Fail Reporting

Per UL and NFPA requirements, an AC Fail trouble signal shall be transmitted after a delay of between 60 and 180 minutes. The FireNET Plus AC Fail delay time is programmable up to 180 minutes, with a default setting of 60 minutes.

For details on programming the AC Fail delay time, please see Section 8 of this manual.

**NOTE:** *The AC Fail Report Delay must be set to 60 – 180 minutes to be compliant with UL 864 9<sup>th</sup> edition requirements.*

## 7.7 Event Reporting Codes

### 7.7.1 Contact ID

Contact ID reporting on the FireNET Plus uses the following format –

Account Number – Event Code – Panel Address – Zone or Device Address

The event code describes the event that is taking place; Alarm, Trouble, Supervisory, etc. The Panel Address is the same as the network address of the FireNET panel. The Zone or Device address indicates the zone or actual device address. Zone or Address reporting is selectable through programming.

Note that Contact ID format uses a “1” (or E) for the event activation, and a “3” (or R) for the restoral. This is not included in the reporting summary list below. The activation and

restore use the same event code, but with the appropriate modifier. For example, a Low Battery report is “1 302” (or E302) and the restore to normal is “3 302” (or R302).

### 7.7.2 SIA

SIA format reporting on the FireNET Plus uses the following format –

Account Number – Event Code – Zone or Device Address

SIA format uses unique event codes for the activation and restoral, rather than the event modifier as is done with Contact ID. Therefore, the list below will indicate two codes in the SIA column; the first code is for the activation, and the second one is for the restore (Low Battery = YT; the restore to normal = YR)

As with Contact ID, the Zone or Address option is programmable. Panel address information is not reported in SIA format.

The following Table shows the event codes for the FireNET Plus communicator, with a brief explanation of what may cause each event.

<b>Panel and Network Events</b>	<b>SIA Event Code</b>	<b>Contact ID Event Code</b>	
AC Fail	AT / AR	301	No AC to Panel
Alarm Silence	FL / FL	406	Alarm Silence Button Pressed
Aux Power Trouble	YP / YQ	312	Short or other Trouble on Aux Power
Battery Low	YT / YR	302	Low Battery
Battery Missing	YM / YR	311	Missing/Disconnected Battery
Comm Fail	YC / YK	354	Dialer Communication Failure
Dialer Missing	IA / IR	350	PC/Dialer switch in wrong position
Disable Address	FB / FU	571	Address Disabled at Panel
Disable Audibles	FT / FJ	520	Notification Appliances Disabled
Disable Loop	FB / FU	571	Loop Disabled
Disable Zone	FB / FU	570	Zone Disabled
Disable Panel Output	FT / FJ	520	Panel Output Disabled
Disable Buzzer	FT / FJ	520	Panel Buzzer Disabled
Disable Ground Trouble	FT / FJ	520	Ground Fault Detection Disabled
Fire Drill	FI / FK	604	Fire Drill Button Pressed on Panel
Ground Fault	YP / YQ	310	Ground on External Panel Wiring
Loop Explorer Prog	LB	628	Local Programming with Loop Explorer
Loop Explorer Reset	FT / FJ	305	Panel Reset after Programming
Missing Network Node	ET / ER	330	Missing FireNET Panel on Network
Missing Peripheral	ET / ER	330	Missing Serial Device

NAC Trouble	FT / FJ	320	Trouble on Notification Appliance Circuit
Network Open/Short	NT / NR	330	Open or Short on Network Connection
Panel Reboot	FT / FJ	305	Reset Button on Display Board Pressed
Panel Reset Button	OR / OR	313	Reset Button on Panel Pressed
Phone Line 1 Trouble	LT / LR	351	Trouble on Dialer Phone Line # 1
Phone Line 2 Trouble	LT / LR	352	Trouble on Dialer Phone Line #2
SLC Open Circuit	ET / ER	331	Open Circuit on Device Polling Loop
SLC Short Circuit	ET / ER	332	Short Circuit on Device Polling Loop
Test Report - Normal	RP	602	Normal Test Report
Test Report - Off Normal	RY	608	Off-Normal Test Report
Test Zones	FI / FK	607	Test Zone Feature Activated
Tested Zone	TS / TE	604	Device Tested while 'Test Zones' Active
Unexpected Network Node	ET	330	Unexpected Panel Added to Network
Unexpected Peripheral	ET / ER	330	Unexpected Serial Device Added to Panel

Loop Device Events	SIA	Contact ID	Event Generated By
Fire	FA / FH	110	FRCM, ATG, ATJ, ALG, ALK/N-V/D, ALG-DH, ACC-V, AIE, ACA-V, DIMM, CZM, AMS <sup>1</sup>
Waterflow (Fire)	SA / SH	113	FRCM, DIMM
CO Alarm	GA / GH	162	ACD-V
Waterflow (Supervisory)	FS / FV	200	FRCM, DIMM
Action = Trouble	FT / FJ	373	FRCM, DIMM, CZM <sup>1</sup>
Action = Pre-Alarm	UA / UR	118	FRCM, DIMM, CZM, ATG, ATJ, ALG, ALK/N-V/D, ACC-V, AIE, ACA-V, ALG-DH <sup>1</sup>
Action = Supervisory	SS / SR	203	FRCM, DIMM, CZM <sup>1</sup>
Action = Supervisory	SS / SR	200	ATG, ATJ, ALG, ALK/N-V/D, AIE, ACA-V, ALG-DH, ACC-V, AMS, FRCM, DIMM
Action = Auxiliary	UA / UH	140	FRCM, DIMM, CZM <sup>1</sup>
Action = Silence	FL / FL	406	FRCM, DIMM, CZM <sup>1</sup>
Action = Reset	OR / OR	313	FRCM, DIMM, CZM <sup>1</sup>
Supervised Loop Trouble	FT / FJ	373	FRCM, DIMM, CZM, SOM
Input Trouble (Waterflow and General Supervision)	ST / SJ	373	FRCM
Missing Device	FY / FJ	373	FRCM, SOM, R2M, DIMM, CZM, ASB, ASBL, AMS
Missing Sensor	FY / FJ	380	ALG, AIE, ATG, ALG-DH, ALN-V, ACC-V, ATJ-EA, ALK-D
Wrong Device Type / Bad Data Trouble	FT / FJ	380	All Modules and Sensors
Double Address	FT / FJ	373	All Modules and Sensors <sup>2</sup>
Unexpected Device	XE / FJ	373	All Modules and Sensors <sup>2</sup>
Maintenance Trouble	FT / FJ	393	ALG, ALK, ALG-DH, AIE, ACA-V

Internal Trouble	FT / FJ	380	ALG, ALK, ALG-DH, AIE, ACA-V
No Auxiliary Power	FT / FJ	373	CZM, ASB, ASBL, SOM-A, SOM-AI

Note #1 – This event can also be generated by Panel and I/O Module Inputs.

Note #2 – Zone information is not reported for this event.

Note #3 – In SIA format, the following events use the same code for the activation and restore: Alarm Silence (FL / FL) and Panel Reset (OR / OR).

Note #4 – See device compatibility section (5.1) for complete model numbers

## Section 8 - Advanced Front Panel Operations and Programming (Access Level 3)

---

### 8.1 Access Level Overview

The FireNET Plus has 3 modes of operation. Access Levels 1 and 2 are operational levels that allow the user to perform operational commands such as silencing an alarm or resetting the panel. Access Levels 1 and 2 are explained in further detail in Section 7 - Basic Front Panel Operation and Programming.

Access Level 3 is an installer level operating mode that allows the user to perform system programming used to configure the FireNET Plus fire alarm system.

Some of the basic programming functions for the FireNET Plus control panel can be done from the front panel controls. To program the FireNET Plus fire alarm system using a PC, you may use the Loop Explorer software tool.

This section covers basic programming functions that can be performed by using the front panel controls of the FireNET Plus fire alarm control panel.

#### 8.1.1 Entering Access Level 3

In order to enter Access Level 3 operating mode you must first enter Access Level 2.

To enter into **Access Level 3** follow these steps:

1. Press any arrow key to enable the panel.
2. Using the arrow keys enter the 5 digit code for Access Level 2. You can only use digit values of 1-4. The up/down arrow keys represent the values 1-4. Up = 1, Right = 2, Down = 3, and Left = 4. The default Access Level 2 code is 22222
3. Press the Enter key. The front panel graphic display will confirm you are in Access Level 2.
4. Press the right arrow key to access the Access Level 2 Main Menu.
5. Press the down arrow key until **Access Level 3** is highlighted with a triangular arrow to the left of it. Press the right arrow key to select **Access Level 3**.
6. Using the arrow keys enter the 5 digit Access Level 3 code. Digit values are 1-4 only. The default Access Level 3 code is 33333.
7. Press Enter.

Note: If you back out of the Access Level 3 menu using the **Exit** button or the left arrow key, you will have to re-enter the code to go back into Access Level 3 operating mode.

## 8.2 Access Level 3 Menu

---

Figure 8.2 shows the menu structure of the Access Level 3 main menu. You can scroll up and down using the arrow keys to highlight each menu option. Once the option is highlighted with a triangular arrow to the left of it, you can select the option by pressing the right arrow key.

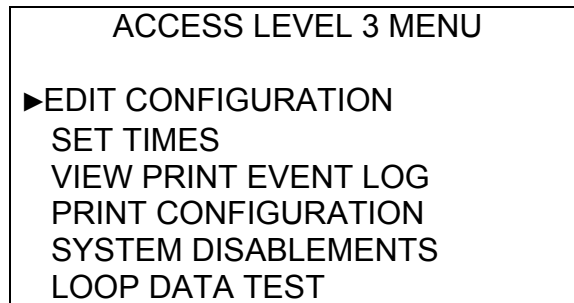

Figure 8.2 Access Level 3 Menu Structure

### 8.2.1 Edit Configuration

The Edit Configuration menu option displays a sub-menu with even more options to select. Figure 8.2.1 indicates these options.

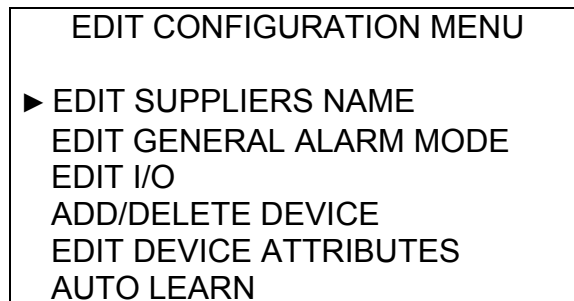

Figure 8.2.1 Edit Configuration Menu Structure

#### 8.2.1.1 Edit Suppliers Name

The suppliers name is a custom message that is displayed on the front panel LCD status display in normal operation, just under the time/date information at the top of the screen.

The suppliers name can be any text message up to 40 characters long. The default suppliers name message is "Auto Configured Panel".

From the EDIT CONFIGURATION MENU, highlight “EDIT SUPPLIERS NAME” by using the up down arrow keys then select it by pressing the right arrow key.

Using the left and right arrow keys, select the character you want to edit. Using the up and down arrow keys scroll through available characters that can be used. Refer to the on-screen instructions for additional information.

### **8.2.1.2 Edit General Alarm Mode**

The FireNET Plus can be programmed to operate in two different ring modes.

“Common” ring mode activates all audible and visual notification appliance circuits when a fire alarm is activated. This is the default mode of the panel.

“Zonal” ring mode activates only the audible and visual notification appliances that are programmed into the same zone as the device causing the alarm.

Select EDIT GENERAL ALARM MODE from the EDIT CONFIGURATION MENU and use the arrow keys to scroll between “Common” and “Zonal”. Follow the on screen prompts or use the Help (?) button for additional information.

### **8.2.1.3 Edit I/O**

The EDIT I/O menu option allows the user to set the attributes of all the FireNET Plus control panel input and output circuits. Selecting EDIT I/O displays a sub-menu giving the user the choice of “Edit Panel I/O” or “Edit Remote I/O”.

#### **8.2.1.3.1 Edit Panel I/O**

##### **Edit Panel Inputs**

Selecting “Edit Panel Inputs” allows the user to edit the Programmable Function button input characteristics. This input has the following properties that can be edited. Select each menu option and follow the on screen prompts or press the Help (?) button for further information.

##### Zone

- Selecting this option allows the user to program which software zone the input will be placed in. Default is 0.
- Input Delay
  - An Input delay can be programmed (where acceptable by the Authority Having Jurisdiction) in 10-second increments up to 2 minutes.
- Input Latch
  - The input can be programmed as latching or non-latching. Latching requires the panel to be reset before the condition is cleared. Non-latching resets the condition automatically when the input returns to normal.

- Input Action
  - Input action is the type of event that occurs when the input is activated. Choose between Trouble, Pre-Alarm, Supervisory, Auxiliary, Silence Alarm, Reset, Transparent, Disablement, Test, or Fire.
- Edit Location Text
  - This option allows the user to scroll through the available characters using the arrow keys, and create a custom text message up to 40 characters describing the input.

## Edit Panel Outputs

Selecting “Edit Panel Outputs” allows the user to select and edit the following panel output circuits.

- Notification Appliance Circuit 1
- Notification Appliance Circuit 2
- Fire Relay
- Trouble Relay
- Supervisory Relay

Each output circuit has the following properties that can be edited. Select each menu option and follow the on screen prompts or press the Help (?) button for further information.

- Zone
  - Selecting this option allows the user to program which software zone the input will be placed in. Default is 0.
- Output Attributes
  - This option allows you to select the output attributes flags for general alarm, silenceable, supervisory output, trouble output, and Strobe Output. (Strobe option for NAC outputs only).
- Delay Stage 1
  - If you are using staged evacuation. This option sets the delay for stage 1 in 30 second increments up to 5 minutes maximum (Not Available for NAC outputs).
- Delay Stage 2
  - If you are using staged evacuation. This option sets the delay for stage 2 in 30 second increments up to 5 minutes maximum (Not Available for NAC outputs).
- Test Device Output
  - This option allows the output to be manually turned on or off by the user.
- Configure Output as Auxiliary (NAC only)
  - This option allows NAC Outputs to be alternately programmed as power outputs such as constant power, door holder power or resettable power.

**NOTE:** Panel Outputs can be programmed into three primary categories:

- Common
  - When output attribute flags are set for general event categories, the output operation will follow the common activation of that event type. General Alarm mode should be set to “common” for this operation.



- Zone
  - When outputs are assigned to zones, the output operation can be triggered on a zoned basis. General alarm mode should be set to “zonal” for this operation.
- Programmable
  - When outputs are not assigned to general event categories via output attributes, the output operation is programmable by using Cause and Effect.

### **Edit Default Pattern**

“Edit Default Pattern” allows you to select the on-board NAC circuit output pattern. The available options are Continuous, Temporal, and March. The default is Temporal.

### **Edit Alarm Verification**

The alarm verification time value can be set between 5 and 60 seconds. This value must be to 60 seconds to be compliant with UL864 9<sup>th</sup> Edition. Default value is 60 seconds. (See the prefix of this manual for additional details).

### **Edit AC Fail Report Delay**

The AC Fail report delay time value can be set between 0 and 180 minutes. Default value is 60 minutes. This value must be set between 60 and 180 minutes to be compliant with UL864 9<sup>th</sup> Edition. (See the prefix of this manual for additional details).

### **8.2.1.3.2 Edit Remote I/O**

I/O Board Addresses 1 – 32 can be selected within this menu. Input Channels can be edited within this menu. Programming attributes are the same as described in panel input menu. Output Channels can be edited within this menu. Programming attributes are the same as described in panel output menus. Each I/O board has 16 input/output channels. Each I/O Channel can be selected to be either an input or an output.

### 8.2.1.3.3 Add / Edit Dialer

This option allows the integrated dialer (DACT) to be enabled and programmed.

**Enabling the DACT:** To enable the DACT, select “Add Dialer” from the Edit I/O menu and press the Enter button.

**Programming the DACT:** From the Edit I/O menu select “Edit Dialer”. You will see the following display.

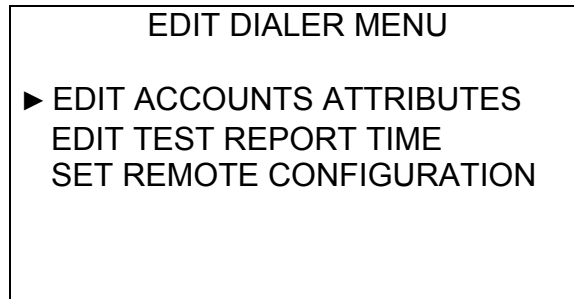

Select *Edit Accounts Attributes* to begin programming.

#### 8.2.1.3.3.1 Edit Account Attributes

The DACT supports four accounts for reporting events. Events are reported to each account in order and by priority; this means that at a minimum, Account 1 must be programmed. For most installations Accounts 1 and 2 will be used.

Select the account you wish to program from the list.

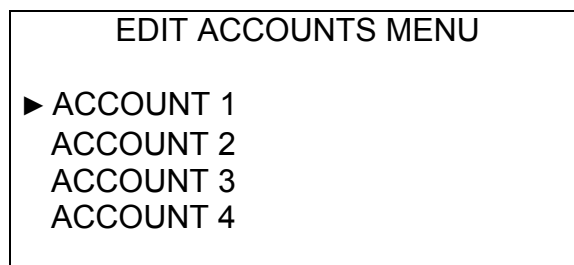

Select the option you wish to program. The options are the Account Number, Dialer Protocol (reporting format), and Phone Number.

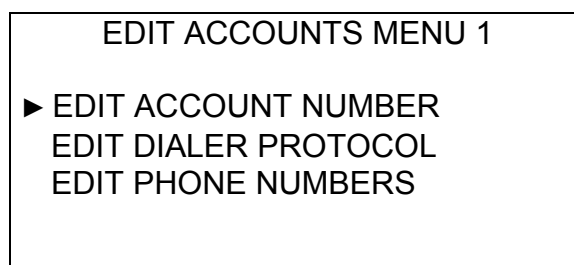

- **Edit Account Number** – Using the up and down arrow keys on the panel keypad, enter the account number for the selected account. Use the right arrow key to advance to the next digit location. Press the Enter button when finished to save the data.

Valid characters are 0 – 9, B – F. Note that only the first four digits are reported in Contact ID format. Up to 6 digits may be used with SIA format.

**NOTE:** For correct DACT operation, always enter at least 4 digits. If you are using a 3 digit account number, be sure to enter a leading 0 (account # 123 should be entered as 0123).

- **Edit Dialer Protocol:** Use the up and down arrow key to select the reporting format for your account. Press the Enter key after making your selection.
- **Edit Phone Number:** Using the up and down arrow keys on the panel keypad, enter the monitoring station receiver phone number for the selected account. Use the right arrow key to advance to the next digit location. Press the Enter button when finished to save the data.

Valid characters are 0 – 9. A comma (,) may be used to generate a 3 second dialing pause.

If the phone number field is left empty for an account (no phone number programmed), the FireNET Plus will not use that account.

**Note:** To comply with UL and NFPA standards, the FireNET Plus must be programmed for backup reporting. To accomplish this, program an account number and phone number for accounts 1 and 2. Both phone numbers must be different.

**Note:** To comply with UL and NFPA standards the FireNET Plus may not be programmed to call a telephone number that is call-forwarded to the DACR.

### 8.2.1.3.3.2 Edit Test Report Time

The program the test report time, select *Edit Test Report* from the Edit Dialer menu.

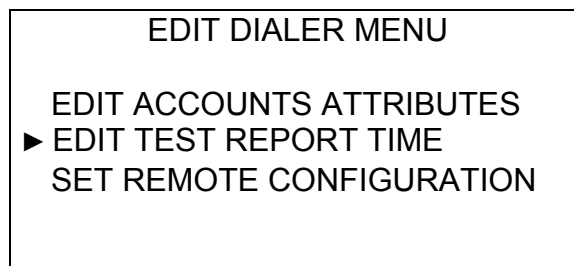

Use the up or down arrow key to select the test report time. The test report will be sent every 24 hours at the time selected. Press the Enter button when the desired time is displayed.

#### **8.2.1.3.3.3 Set Remote Configuration**

This option enables the panel to accept a programming download from a remote computer.

#### **8.2.1.4 Add/Delete Device**

Selecting the ADD/DELETE DEVICE Menu Option allows the user to add or delete an SLC loop device to the loop. To add a loop device using this menu option follow these instructions.

##### **8.2.1.4.1 To Add an SLC Loop Device**

1. Select ADD DEVICE from the EDIT CONFIGURATION MENU by highlighting it, then pressing the right arrow key to select.
2. A sub-menu listing each of the 2 possible SLC loops is displayed. Highlight one of the SLC loops then select it by pressing the right arrow key. Do not attempt to add devices to loop 2 if the expander board has not been installed.
3. Using the up/down arrow keys scroll to the address value that the new SLC loop device will utilize (1-127 for Sensors and Modules, 128 – 254 for ASB & ASBL). Only open address values will be displayed which helps to eliminate duplicate address problems. Press the right arrow key to select.
4. Scroll through the list of possible SLC loop devices by using the up/down arrow keys. Press the right arrow key to select.
5. Press the “Enter” button to accept the new device.
6. Follow the prompts on screen or use the Help (?) button for further information.

##### **8.2.1.4.2 To Delete an SLC Loop Device**

1. Select the ADD/DELETE DEVICE menu.
2. Using the scroll keys to navigate, select the applicable loop that the device resides on, and then select the device to be deleted.
3. Press the “ENTER” button to perform the deletion.

### 8.2.1.5 Edit Device Attributes

Selecting EDIT DEVICE ATTRIBUTES from the EDIT CONFIGURATION MENU allows the user to set attributes specific to each SLC loop device on the system. After selecting the SLC loop where the device is located, the user can scroll through each SLC device on that loop and set attributes specific to that device.

The device attributes are different for the three different point types - Detector, Input, or Output. Following is a description of the attributes that can be set for each point type.

- Detector (Sensor)
  - Set Zone
    - This option allows the user to set the software zone this device will reside in. Do not use zone 0 for SLC loop devices.
  - Edit Location Text
    - This option allows the user to scroll through and enter up to 40 characters describing the device location
  - Change Sensor Type
    - This option allows you to change the type of sensor currently assigned to this address.
  - Set Sensitivity
    - This option allows the user to set both the day and night sensitivity levels for this device. Setting the percent per foot obscuration of smoke that must occupy the detectors chamber to cause an alarm programs the smoke detector sensitivity. Setting the temperature that must be reached to cause an alarm (degrees F) programs the heat detector sensitivity. Day and night sensitivity times are configured in another menu location.
  - Set Input Action
    - This option allows the user to change the detector's (sensor) action type to Fire or Supervisory.
- Output Modules (R2M series, SOM series, ASB & ASBL and DH98AR Relay)
  - Set Zone
    - This option allows the user to set the software zone this device will reside in. Do not use zone 0 for SLC loop devices.
  - Edit Location Text
    - This option allows the user to scroll through and enter up to 40 characters describing the device location.
  - Delay Stage 1
    - If you are using staged controls. This option sets the delay for stage 1 in 30 second increments up to 5 minutes maximum (R2M and DH98AR Relay only).
  - Delay Stage 2
    - If the attribute 'Silenceable' is set to Yes (see below), Delay Stage 2 will become visible. This option sets the delay for stage 2 in 30 second increments up to 5 minutes maximum (R2M only).
  - Output Attributes

- General Alarm mode (Common Fire Alarm): This option allows a user to enable or disable the global General Alarm mode for a selected output(s). When enabled, the output follows the panels General Alarm mode (see 8.2.1.2). When disabled, the output will not follow the General Alarm mode, allowing control by cause and effect logic statements.
- Silenceable: This option allows a user to program whether the selected output is silenceable via the alarm silence button on the front panel or not (not available for DH98AR Relay).
- Pre-Alarm Output: This option allows a user to assign a selected output(s) to the Pre-Alarm Group. When assigned to this group, any sensor going into pre-alarm will cause this output group to activate.
- Trouble Output: This option allows users to assign a selected output(s) to the Trouble Group. Any input assigned to this group, or any panel trouble will activate all the outputs assigned to this group.
- Pattern (SOM, ASB & ASBL only): This option allows the user to select the output pattern for the SOM module. Selections are Continuous, Temporal and March.
- Test Device Output: This option allows the output to be manually turned on or off by the user.

**NOTE:** Panel Outputs can be programmed into three primary categories:

- Common
    - When output attribute flags are set for general event categories, the output operation will follow the common activation of that event type. General Alarm mode should be set to “common” for this operation.
  - Zone
    - When outputs are assigned to zones, the output operation can be triggered on a zoned basis. General alarm mode should be set to “zonal” for this operation.
  - Programmable
    - When outputs are not assigned to general event categories via output attributes, the output operation is programmable by using Cause and Effect.
- Input Modules (FRCM, DIMM, CZM, AMS)
    - Set Zone
      - This option allows the user to set the software zone this device will reside in. Do not use zone 0 for SLC loop devices.
    - Edit Location Text
      - This option allows the user to scroll through and enter up to 40 characters describing the device location.
    - Set Input Delay
      - Input delays can be programmed (where acceptable by the Authority Having Jurisdiction) in 10-second increments up to 2 minutes.
    - Set Input Latch

- Each input can be programmed as latching or non-latching. Latching requires the panel to be reset before the condition is cleared. Non-latching resets the condition automatically when the input returns to normal.
- Set Input Action
  - Input action defines the type of event that occurs when the input is activated. Choose between Trouble, Pre-Alarm, Supervisory, Auxiliary, Silence Alarm, Reset, Transparent, Disablement, Test, or Fire.
- Set Input Type (FRCM and DIMM only)
  - This option allows the programmer to define the type of device being monitored, and if the initiating circuit is configured as normally open or normally closed. Available selections are Pull Station, Waterflow, Valve Monitor N/O, Valve Monitor N/C, Duct Detector, Detector, Reset Alarm, Temperature, Pressure, Level, Position, Power, General Supervision, General Purpose N/O EOL, General Purpose N/C EOL, General Purpose N/C no EOL, and Waterflow Non-Silence. The selected Input Type will appear as part of the message on the LCD display during device activation.
- Test Device Output (LED)
  - This option allows the module LED output to be manually turned on or off by the user. This is helpful for locating installed modules by turned on their indicator.

### 8.2.1.6 Auto Learn

Auto Learn is a utility that can be run to quickly identify and enroll all of the SLC loop devices on the FireNET Plus control panel as well as the panel's internal structure and default network routing and nodes.

Auto Learn can be run from the AUTO LEARN sub-menu at any time. When Auto Learn is run, the panel searches each of the 2 possible SLC loops for SLC devices. When it finds a device it identifies which type of device it is, and creates a basic configuration for that device. The installer can then go back and customize the configuration accordingly.

**WARNING:** Running Auto Learn will erase all system programming.

### 8.2.2 Set Times

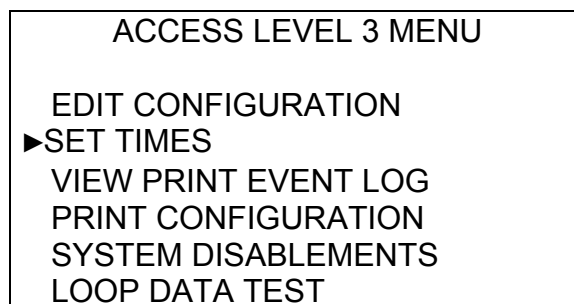

The SET TIMES menu option allows the installer to set the smoke detector calibration time, the day / night sensitivity times, and the Sounder Time-Out for the panel.

### **8.2.2.1 Calibration Time**

This menu option sets the time of day that the panel will perform calibration on the system smoke detectors. Default is 07:00. The time may be adjusted with the up/down arrow keys. The calibration time should be chosen based on an expected time of day when the environmental conditions in the building are stable.

### **8.2.2.2 Day / Night Times**

Day / Night sensitivity is used when you expect environmental conditions to regularly change in the building. By setting the sensitivity lower or higher at certain times of the day or night, false alarms caused by changing environmental conditions may possibly be avoided or reduced.

This menu option allows the installer to program the start and end times for each day of the week for day sensitivity mode. Any times that fall outside of the programmed day start and stop times are considered to be night sensitivity mode.

### **8.2.2.3 Set Sounder Time-Out**

This option allows the user to program the NAC circuit activation time during a Fire alarm. At the end of the programmed time, the notification appliance circuits will turn off automatically. Valid selections are from 5 minutes to 60 minutes, in 5-minute increments. The default setting is 0 minutes, which disables the sounder time-out feature.

**NOTE:** This value must be set to zero (0) minutes to be compliant with UL864 9<sup>th</sup> Edition. (See Prefix of this manual for additional details).

### **8.2.3 View Print Event Log**

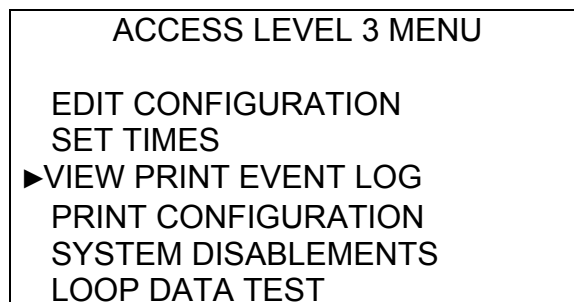

The View Print Event Log menu command allows the user to view the system's 500-event memory log. Any condition outside of normal panel operation generates an entry into the



event log. The event log is a very useful tool for troubleshooting system problems or verifying that certain activities, such as Fire Drills, actually took place.

The View Print Event Log menu option is covered in greater detail in the Testing and Troubleshooting section of this manual.

### 8.2.4 Print Configuration

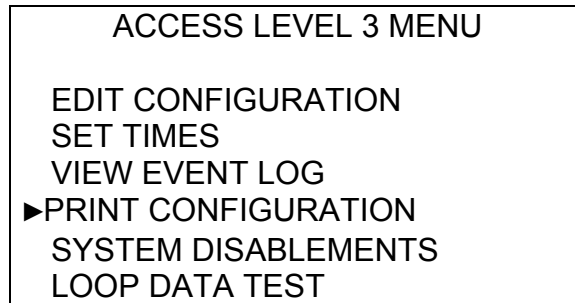

### 8.2.5 System Disablements

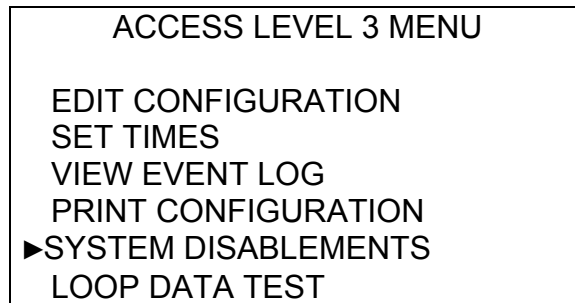

The System Disablements menu option allows the installer to temporarily disable the panel buzzer, ground fault detection, and set the buzzer silence access level. The panel buzzer and ground fault detection are enabled in the panel's default condition. The buzzer silence access level is set to 2 by default.

Disabling any of these options places the panel in a trouble condition. Each disablement of these system devices must be manually reset.

Disabling system devices is typically used on systems where there are intermittent problems, while the problems are being corrected. It is important to note that these features should not be permanently disabled. The installer must make sure buzzer and ground fault detection are re-enabled after corrections to the system are complete.

**NOTE:** The following values must be set to be compliant with UL864 9<sup>th</sup> Edition. See prefix of this manual for additional details.

- Buzzer – Enabled
- Ground Trouble – Enabled
- Buzzer Access Level – 2

## 8.2.6 Loop Data Test

```
ACCESS LEVEL 3 MENU  
  
EDIT CONFIGURATION  
SET TIMES  
VIEW PRINT EVENT LOG  
PRINT CONFIGURATION  
SYSTEM DISABLEMENTS  
▶LOOP DATA TEST
```

Loop Data Test is an installer or service level diagnostic test that is explained in greater detail in the Testing and Troubleshooting section of this manual.

## Section 9 - Testing and Troubleshooting

---

### 9.1 One Man Walk Test - TEST ZONES

---

The one-man walk test feature is intended to allow a single service person the ability to test each device without having to reset the panel each time a device is activated. While in test mode, the panel will automatically reset after 3 seconds following any device activation. This allows a service person to activate a device, verify the panel responds by sounding the audible and visual notification appliances, then move on to the next device without going back to the main panel to reset. The Test Zone feature will only activate outputs & devices that are assigned to General Alarm Mode (Fire alarm) based on the options enabled as described below.

One-man walk test mode is implemented by selecting the TEST ZONES option from the Access Level 2 Main Menu.

Follow these steps to implement a one-man walk test using the TEST ZONES option:

1. Enter Access Level 2 operating mode.
2. Press the right navigational arrow key to access the Main Menu.
3. Scroll down to highlight the TEST ZONES option. Press the right arrow key to select.
4. From the Test Zones Menu use the up/down arrow keys to select which zone to test.
5. Press the right navigational arrow key to display the test options.

#### **Local NAC ON - OFF**

Use the up/down arrow keys to select ON or OFF. Setting this option to ON will make the audible and visual notification circuits (NAC 1 & 2) activate for the 3-second duration of each device tested. Setting this option to OFF disables the audible and visual notification appliance outputs during test mode.

#### **Panel Outputs ON-OFF**

Use the up/down arrow keys to select ON or OFF. Setting this option to ON will make the panel relays function as they have been configured. Setting this option to OFF disables the panel relays during test mode.

Once the test options have been set press "Enter" to start the test or "Exit" to cancel. If you start test mode and want to cancel it anytime within the 15-minute test period, enter Access Level 2 and navigate to TEST ZONES. Enter TEST ZONES and use the right arrow key then Enter to toggle test mode to off.

When a zone is placed into test mode a 15-minute timer is started. If the 15-minute timer expires with no testing done, the test is automatically terminated and the panel is placed back into normal operation. The 15-minute timer is re-started each time a device is tested.

**NOTE** The FireNET Plus panel will be placed in a trouble condition during test mode. The “ON TEST” LED will also illuminate.

## 9.2 View / Print Event Log

---

The View Print Event Log menu command allows the user to view the systems 500-event memory log. Any condition outside of normal operation of the system generates an entry into the event log. The event log is very useful tool for troubleshooting system problems or verifying certain activities such as Fire Drills actually took place.

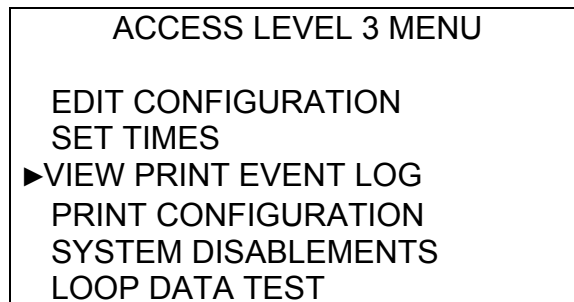

### 9.2.1 View Event Log

To view the event log, you must first enter Access Level 3. Once in Access Level 3, select VIEW PRINT EVENT LOG. Then select “View Event Log”.

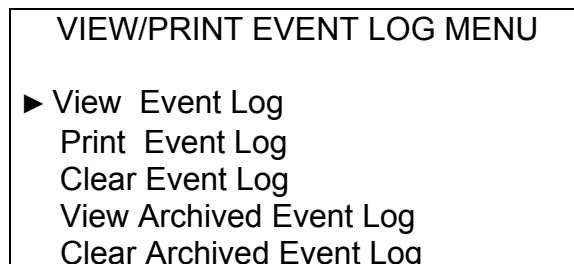

Then select the Event Type Option:

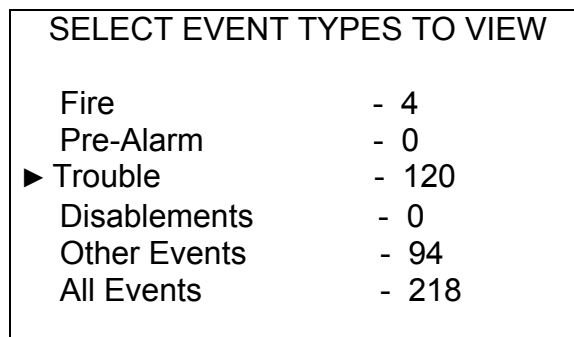

You may view individual events by using the up and down arrow keys:

```
VIEW TROUBLE EVENTS 120/120

* TROUBLE:SOM ZONE 02 *
ADR=012.00 LOOP=1 ND=1 AUTOLEARN
TIME 14:35 05/08/2003
Disconnected trouble Cleared

Use UP/DOWN arrow keys to scroll events
```

### 9.2.2 Print Event Log (Only available on special equipped panels)

To print the event log, you must enter Access Level 3 as noted above. Once in Access Level 3, select VIEW PRINT EVENT LOG. Then select the "Print Event Log".

```
VIEW/PRINT EVENT LOG MENU

View Event Log
▶ Print Event Log
Clear Event Log
View Archived Event Log
Clear Archived Event Log
```

Then select the Event Type Option

```
SELECT EVENT TYPES TO PRINT

▶ Fire - 4
Pre-Alarm - 0
Trouble - 120
Disabling - 0
Other Events - 94
All Events - 218
```

Press the Enter key to start printing those event types.

```
PRINT FIRE EVENTS

Press ENTER to start print.

Press EXIT to quit
Press < to go back.
```

### 9.2.3 Clear Event Log

To clear the event log, you must enter Access Level 3 as noted above. Once in Access Level 3, select VIEW PRINT EVENT LOG. Then select the “Clear Event Log”.

```
VIEW EVENT LOG MENU  
  
View Event Log  
▶ Clear Event Log  
View Archived Event Log  
Clear Archived Event Log
```

Press the Enter key to clear the Event Log, or EXIT to cancel.

```
CLEAR EVENT LOG MENU  
  
Event Log has 218 entries  
  
Press ENTER to clear Event Log.  
  
Press EXIT to quit  
Press < to go back.
```

### 9.3 Loop Data Test

---

To start the Loop Data Test function, you must first enter Access Level 3. Once in Access Level 3, you then must select the Loop Data Test option.

The Loop Data Test Function is a troubleshooting tool that in most cases will never be necessary. When the time does come at that problem job site, the Loop Data Test Function can be easily activated to monitor communication between the FireNET Plus and loop devices. This tool displays the time and date of the test activation, the number of successful and unsuccessful communication packets on the loop, and the current date and time. The Loop Data Test Function runs in the background and has no affect on the panel's ability to perform its intended functions of detection, notification, and control. It is therefore possible to start a Loop Test during a normal business day and let it monitor an individual loop overnight, over a weekend, or during the week. The maximum number of readings is 9,999,999. This will allow a loop to be monitored in excess of one week.

In the event that a large number of bad data readings are received, a review of the installation conditions must be conducted. Possible sources of communication problems are bad wiring, poor wiring practices, large sources of electrical noise (large machines, radio transmitters), improper grounding practices, and the like. When used with good engineering practices, the Loop Data Test Function serves as an integral method to verify loop integrity.

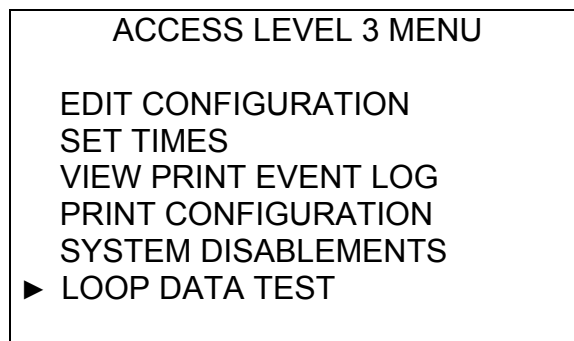

Select which Loop you wish to test.

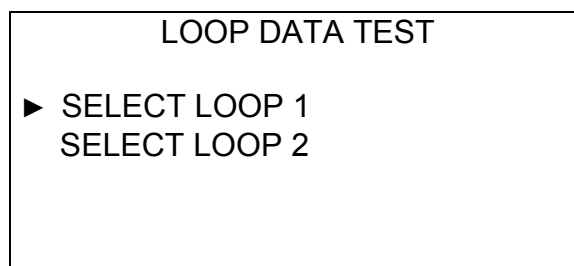

Then select "START TEST".

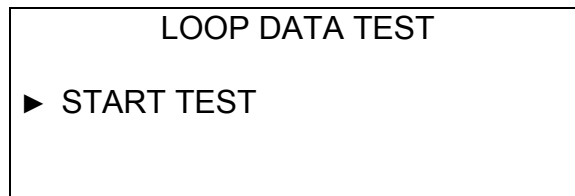

The Loop Data Test result will then display in real time on the screen.

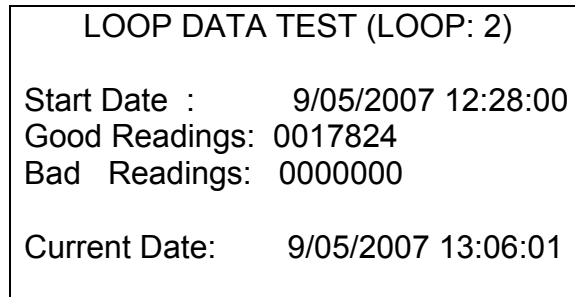

Press the Exit button when the Loop Data Test is completed.



## 9.4 Troubleshooting

---

This section is currently being developed from data collected from installation sites and technical support inquiries.

The following is an example (in FAQ format) of the information being developed:

**Q – I need to change an ALG-V smoke sensor to an ATG-EA heat sensor. Do I have to auto-learn the loops again?**

**A –** No, you can change the device type from smoke sensor to heat sensor. From the Access Level 3 menu choose Edit Configuration then Edit Device Attributes. Select the loop and address of the smoke sensor and then select Change Sensor Type. Select the new sensor type then press Enter. The change will take place immediately.

**Q – My strobes are not flashing correctly when there is an alarm.**

**A –** Check the output pattern; strobes usually require a Continuous (Steady) output pattern. From the Access Level 3 menu choose Edit Configuration then choose Edit I/O. Select Edit Panel I/O then Edit Default Pattern. Use the up and down arrow keys to highlight the selected pattern then press the Enter button.

## **9.5 Trouble Conditions**

---

### ***Network Troubles:***

#### **9.5.1 Network open or short circuit trouble**

This is quite self explanatory and indicates a cabling trouble between two nodes. However, by observing the green and red LEDs on the network card it is possible to see whether the trouble is on the incoming or outgoing network circuit. If the red LED is off then the trouble is on the incoming circuit, and if the green LED is off the trouble is on the outgoing circuit. Thus, if there are two panels with network LEDs not lit (a red on one and a green on the other) the trouble can be identified as between those two panels.

#### **9.5.2 Unexpected network card**

Should a network card be installed in a control panel that is already configured and working, the panel does not expect to have a network card installed; therefore this trouble message will appear. The panel must be re-configured to enable it to expect a network card.

#### **9.5.3 Unexpected network node**

If a new network panel is connected to an already working network, the rest of the network will not expect to see the additional node and will announce this trouble. The unexpected network panel will respond to network events as per the default configuration and all other panels will respond to events from the new network panel as per the default configuration. All panels must be configured to see the updated total of panels connected to the network.

#### **9.5.4 Network node missing**

This message will be displayed on all panels if a network node they are expecting to communicate with does not answer within approximately 100 seconds. This may occur if a control panel loses all power or if both the in and out network connections are disconnected from the panel.

#### **9.5.5 Network card not installed**

If a control panel is configured to be part of a network and a network card is not installed, the panel will display this message.

#### **9.5.6 Network card address incorrect**

Once a panel is configured to expect a network card to be present it will also know which address (set on the network card DIP switch) to expect. If it detects that a card is installed but the address does not match the one expected, then this trouble message will be displayed. If the address of a network card must be changed then this should be done with both the AC and battery backup power off. Once the address is set and the panel is powered up, the panel must be re-programmed to see the new address.

### **9.5.7 Network comms trouble**

Highly sophisticated error checking and filtering is used in the FireNET Plus network protocol. It is possible under extreme conditions for data packets to become corrupted and not be received by a panel. In these circumstances this trouble message will be displayed. This indicates a highly degraded transmission path and occurrence of this trouble should be investigated. Possible causes are cable lengths greater than those specified, cable specification other than that specified or high levels of electromagnetic interference.

DACT Troubles (FNP-equipped with internal DACT only):

**9.5.8 Comms Phone Line 1 (or 2) Trouble** – The indicated phone line is not being detected by the FireNET Plus panel.

- Use a voltmeter to check the voltage on the phone line. A normal phone line will measure approximately 48 VDC.

**Caution:** *The voltage present during ringing for an incoming call can be over 100 volts AC. Use caution when measuring phone line voltages.*

- Check to be sure that the incoming phone line is correctly connected to the L1T and L1R (or L2T and L2R) line connections.
- Check wiring of the RJ31X jack(s). Be sure that the DACT is connected for proper line seizure.

**9.5.9 Comms Fail #** - The panel is unable to report to the monitoring station receiver. The number indicates the account that failed.

- Confirm that the monitoring station telephone number is correct in the program.
- Verify that the correct communication format is selected (Contact ID or SIA).
- Check wiring of the RJ31X jack(s). Be sure that the DACT is connected for proper line seizure.
- Using the communicator phone line, make a test phone call to the receiver. Listen for noise or distortion on the line. This can prevent proper communication between communicator and receiver.
- You may also wish to monitor the communication session using a telephone test set in parallel with the phone line. This may help to determine why the DACT is having trouble communicating the information. Use caution when working with phone lines, as ringing voltage may be over 100 VAC!

## Section 10 - Installation Records

---

This section of the manual can be used to record the SLC points, RS485 addresses, and Network nodes you have installed on the system. The tables included in this section can be filled out with this information to be referred back to later for service or troubleshooting purposes.

### 10.1 SLC Loop Point Record

---

Use the example below to complete the information in Table 10.1 for the SLC loop points on the system:

Loop (1-2)	Address (Sub)	Zone (1-500)	Description	Loop (1-2)	Address (Sub)	Zone (1-500)	Description
1	015	1	(FRCME-P) Main Entry Pull Station	2	015	35	(ATG-EA) Office Closet Heat Detector
	001		N/A		001	N/A	
	002		N/A		002	N/A	
1	016		(R2M Module w/sub addresses)	2	016	35	(ALG-V) Office Smoke Detector
	001	2	Primary Floor Elevator Recall		001	N/A	
	002	3	Secondary Floor Elevator Recall		002	N/A	

### 10.2 RS485 Bus Device Record

---

Use the example below to complete the information in Table 10.2 for the RS485 bus devices installed on the system.

Address (1-32)	Device	Description	Location
1	FN-4127-IO	I/O board used for graphic annunciator driver	FireNET Plus Control Panel
2	FN-LCD-S	Local Serial LCD Annunciator	Main Lobby

### 10.3 Network Node Device Record

---

Use the example below to complete the information in Table 10.3 for the Network devices installed on the system.

Node (1-64)	Device	Description	Location
1	Control Panel	FireNET Plus FACP for the main building	South wall of the main entry lobby
2	Control Panel	FireNET Plus FACP for Warehouse	Warehouse

**Table 10.1 FireNET Plus SLC Loop Point Record**

Loop (1-2)	Address (Sub)	Zone (1-500)	Description	Loop (1-2)	Address (Sub)	Zone (1-500)	Description
	<b>001</b>				<b>001</b>		
	001				001		
	002				002		
	<b>002</b>				<b>002</b>		
	001				001		
	002				002		
	<b>003</b>				<b>003</b>		
	001				001		
	002				002		
	<b>004</b>				<b>004</b>		
	001				001		
	002				002		
	<b>005</b>				<b>005</b>		
	001				001		
	002				002		
	<b>006</b>				<b>006</b>		
	001				001		
	002				002		
	<b>007</b>				<b>007</b>		
	001				001		
	002				002		
	<b>008</b>				<b>008</b>		
	001				001		
	002				002		
	<b>009</b>				<b>009</b>		
	001				001		
	002				002		
	<b>010</b>				<b>010</b>		
	001				001		
	002				002		
	<b>011</b>				<b>011</b>		
	001				001		
	002				002		
	<b>012</b>				<b>012</b>		
	001				001		
	002				002		
	<b>013</b>				<b>013</b>		
	001				001		
	002				002		
	<b>014</b>				<b>014</b>		
	001				001		
	002				002		

Loop (1-2)	Address (Sub)	Zone (1-500)	Description	Loop (1-2)	Address (Sub)	Zone (1-500)	Description
	<b>015</b>				<b>015</b>		
	001				001		
	002				002		
	<b>016</b>				<b>016</b>		
	001				001		
	002				002		
	<b>017</b>				<b>017</b>		
	001				001		
	002				002		
	<b>018</b>				<b>018</b>		
	001				001		
	002				002		
	<b>019</b>				<b>019</b>		
	001				001		
	002				002		
	<b>020</b>				<b>020</b>		
	001				001		
	002				002		
	<b>021</b>				<b>021</b>		
	001				001		
	002				002		
	<b>022</b>				<b>022</b>		
	001				001		
	002				002		
	<b>023</b>				<b>023</b>		
	001				001		
	002				002		
	<b>024</b>				<b>024</b>		
	001				001		
	002				002		
	<b>025</b>				<b>025</b>		
	001				001		
	002				002		
	<b>026</b>				<b>026</b>		
	001				001		
	002				002		
	<b>027</b>				<b>027</b>		
	001				001		
	002				002		
	<b>028</b>				<b>028</b>		
	001				001		
	002				002		

Loop (1-2)	Address (Sub)	Zone (1-500)	Description	Loop (1-2)	Address (Sub)	Zone (1-500)	Description
	<b>029</b>				<b>029</b>		
	001				001		
	002				002		
	<b>030</b>				<b>030</b>		
	001				001		
	002				002		
	<b>031</b>				<b>031</b>		
	001				001		
	002				002		
	<b>032</b>				<b>032</b>		
	001				001		
	002				002		
	<b>033</b>				<b>033</b>		
	001				001		
	002				002		
	<b>034</b>				<b>034</b>		
	001				001		
	002				002		
	<b>035</b>				<b>035</b>		
	001				001		
	002				002		
	<b>036</b>				<b>036</b>		
	001				001		
	002				002		
	<b>037</b>				<b>037</b>		
	001				001		
	002				002		
	<b>038</b>				<b>038</b>		
	001				001		
	002				002		
	<b>039</b>				<b>039</b>		
	001				001		
	002				002		
	<b>040</b>				<b>040</b>		
	001				001		
	002				002		
	<b>041</b>				<b>041</b>		
	001				001		
	002				002		
	<b>042</b>				<b>042</b>		
	001				001		
	002				002		

Loop (1-2)	Address (Sub)	Zone (1-500)	Description	Loop (1-2)	Address (Sub)	Zone (1-500)	Description
	<b>043</b>				<b>043</b>		
	001				001		
	002				002		
	<b>044</b>				<b>044</b>		
	001				001		
	002				002		
	<b>045</b>				<b>045</b>		
	001				001		
	002				002		
	<b>046</b>				<b>046</b>		
	001				001		
	002				002		
	<b>047</b>				<b>047</b>		
	001				001		
	002				002		
	<b>048</b>				<b>048</b>		
	001				001		
	002				002		
	<b>049</b>				<b>049</b>		
	001				001		
	002				002		
	<b>050</b>				<b>050</b>		
	001				001		
	002				002		
	<b>051</b>				<b>051</b>		
	001				001		
	002				002		
	<b>052</b>				<b>052</b>		
	001				001		
	002				002		
	<b>053</b>				<b>053</b>		
	001				001		
	002				002		
	<b>054</b>				<b>054</b>		
	001				001		
	002				002		
	<b>055</b>				<b>055</b>		
	001				001		
	002				002		
	<b>056</b>				<b>056</b>		
	001				001		
	002				002		



Loop (1-2)	Address (Sub)	Zone (1-500)	Description	Loop (1-2)	Address (Sub)	Zone (1-500)	Description
	<b>057</b>				<b>057</b>		
	001				001		
	002				002		
	<b>058</b>				<b>058</b>		
	001				001		
	002				002		
	<b>059</b>				<b>059</b>		
	001				001		
	002				002		
	<b>060</b>				<b>060</b>		
	001				001		
	002				002		
	<b>061</b>				<b>061</b>		
	001				001		
	002				002		
	<b>062</b>				<b>062</b>		
	001				001		
	002				002		
	<b>063</b>				<b>063</b>		
	001				001		
	002				002		
	<b>064</b>				<b>064</b>		
	001				001		
	002				002		
	<b>065</b>				<b>065</b>		
	001				001		
	002				002		
	<b>066</b>				<b>066</b>		
	001				001		
	002				002		
	<b>067</b>				<b>067</b>		
	001				001		
	002				002		
	<b>068</b>				<b>068</b>		
	001				001		
	002				002		
	<b>069</b>				<b>069</b>		
	001				001		
	002				002		
	<b>070</b>				<b>070</b>		
	001				001		
	002				002		

Loop (1-2)	Address (Sub)	Zone (1-500)	Description	Loop (1-2)	Address (Sub)	Zone (1-500)	Description
	<b>071</b>				<b>071</b>		
	001				001		
	002				002		
	<b>072</b>				<b>072</b>		
	001				001		
	002				002		
	<b>073</b>				<b>073</b>		
	001				001		
	002				002		
	<b>074</b>				<b>074</b>		
	001				001		
	002				002		
	<b>075</b>				<b>075</b>		
	001				001		
	002				002		
	<b>076</b>				<b>076</b>		
	001				001		
	002				002		
	<b>077</b>				<b>077</b>		
	001				001		
	002				002		
	<b>078</b>				<b>078</b>		
	001				001		
	002				002		
	<b>079</b>				<b>079</b>		
	001				001		
	002				002		
	<b>080</b>				<b>080</b>		
	001				001		
	002				002		
	<b>081</b>				<b>081</b>		
	001				001		
	002				002		
	<b>082</b>				<b>082</b>		
	001				001		
	002				002		
	<b>083</b>				<b>083</b>		
	001				001		
	002				002		
	<b>084</b>				<b>084</b>		
	001				001		
	002				002		

Loop (1-2)	Address (Sub)	Zone (1-500)	Description	Loop (1-2)	Address (Sub)	Zone (1-500)	Description
	<b>085</b>				<b>085</b>		
	001				001		
	002				002		
	<b>086</b>				<b>086</b>		
	001				001		
	002				002		
	<b>087</b>				<b>087</b>		
	001				001		
	002				002		
	<b>088</b>				<b>088</b>		
	001				001		
	002				002		
	<b>089</b>				<b>089</b>		
	001				001		
	002				002		
	<b>090</b>				<b>090</b>		
	001				001		
	002				002		
	<b>091</b>				<b>091</b>		
	001				001		
	002				002		
	<b>092</b>				<b>092</b>		
	001				001		
	002				002		
	<b>093</b>				<b>093</b>		
	001				001		
	002				002		
	<b>094</b>				<b>094</b>		
	001				001		
	002				002		
	<b>095</b>				<b>095</b>		
	001				001		
	002				002		
	<b>096</b>				<b>096</b>		
	001				001		
	002				002		
	<b>097</b>				<b>097</b>		
	001				001		
	002				002		
	<b>098</b>				<b>098</b>		
	001				001		
	002				002		

Loop (1-2)	Address (Sub)	Zone (1-500)	Description	Loop (1-2)	Address (Sub)	Zone (1-500)	Description
	<b>099</b>				<b>099</b>		
	001				001		
	002				002		
	<b>100</b>				<b>100</b>		
	001				001		
	002				002		
	<b>101</b>				<b>101</b>		
	001				001		
	002				002		
	<b>102</b>				<b>102</b>		
	001				001		
	002				002		
	<b>103</b>				<b>103</b>		
	001				001		
	002				002		
	<b>104</b>				<b>104</b>		
	001				001		
	002				002		
	<b>105</b>				<b>105</b>		
	001				001		
	002				002		
	<b>106</b>				<b>106</b>		
	001				001		
	002				002		
	<b>107</b>				<b>107</b>		
	001				001		
	002				002		
	<b>108</b>				<b>108</b>		
	001				001		
	002				002		
	<b>109</b>				<b>109</b>		
	001				001		
	002				002		
	<b>110</b>				<b>110</b>		
	001				001		
	002				002		
	<b>111</b>				<b>111</b>		
	001				001		
	002				002		
	<b>112</b>				<b>112</b>		
	001				001		
	002				002		

Loop (1-2)	Address (Sub)	Zone (1-500)	Description	Loop (1-2)	Address (Sub)	Zone (1-500)	Description
	<b>113</b>				<b>113</b>		
	001				001		
	002				002		
	<b>114</b>				<b>114</b>		
	001				001		
	002				002		
	<b>115</b>				<b>115</b>		
	001				001		
	002				002		
	<b>116</b>				<b>116</b>		
	001				001		
	002				002		
	<b>117</b>				<b>117</b>		
	001				001		
	002				002		
	<b>118</b>				<b>118</b>		
	001				001		
	002				002		
	<b>119</b>				<b>119</b>		
	001				001		
	002				002		
	<b>120</b>				<b>120</b>		
	001				001		
	002				002		
	<b>121</b>				<b>121</b>		
	001				001		
	002				002		
	<b>122</b>				<b>122</b>		
	001				001		
	002				002		
	<b>123</b>				<b>123</b>		
	001				001		
	002				002		
	<b>124</b>				<b>124</b>		
	001				001		
	002				002		
	<b>125</b>				<b>125</b>		
	001				001		
	002				002		
	<b>126</b>				<b>126</b>		
	001				001		
	002				002		
	<b>127</b>				<b>127</b>		
	001				001		
	002				002		

**Table 10.2 RS485 Bus Device Record**

Address (1-32)	Device	Description	Location
1			
2			
3			
4			
5			
6			
7			
8			
9			
10			
11			
12			
13			
14			
15			
16			
17			
18			
19			
20			
21			
22			
23			
24			
25			
26			
27			
28			
29			
30			
31			
32			

**Table 10.3 Network Node Device Record**

Node (1-64)	Device	Description	Location
1			
2			
3			
4			
5			
6			
7			
8			
9			
10			
11			
12			
13			
14			
15			
16			
17			
18			
19			
20			
21			
22			
23			
24			
25			
26			
27			
28			
29			
30			
31			
32			

Node (1-64)	Device	Description	Location
33			
34			
35			
36			
37			
38			
39			
20			
41			
42			
43			
44			
45			
46			
47			
48			
49			
50			
51			
52			
53			
54			
55			
56			
57			
58			
59			
60			
61			
62			
63			
64			

These tables may be photocopied if additional pages are necessary.



# Appendix A - Compatible Devices

## A.1 Two-Wire Smoke Detectors

Table A.1 lists the 2-wire smoke detectors that are compatible with the CZM conventional zone module.

**Table A.1: Compatible 2-Wire Smoke Detectors with the Hochiki FireNET CZM Module**

Manufacturer	Model Number	Compatibility ID				Number of Detectors per CZM Module
		Detector	Detector Identifier	Base	Base Identifier	
Hochiki	SLK-24F	Photoelectric	HD-3	HSB-224	HB-53	25
	SIH-24F	Ionization	HD-3	HSB-224	HB-53	25
	SLR-24H	Photoelectric w/ heat	HD-3	NS4-224, NS6-224	HB-5	25
	SLR-24V	Photoelectric	HD-3	NS4-224, NS6-224	HB-5	25
	SLR-835/-835W	Photoelectric (8-35V)	HD-3	NS4-224, NS6-224, NS4-224W, NS6-224W	HB-5	18
	SLR-835H/-835HW	Photoelectric (8-35V) w/ thermal	HD-5	NS4-224, NS6-224, NS4-224W, NS6-224W	HB-5	18
	SLR-835B-2	Photoelectric (8-35V) (baseless)	HD-6	N/A	N/A	18
	SLR-835BH-2	Photoelectric (8-35V) w/ thermal (baseless)	HD-6	N/A	N/A	18
	SIJ-24	Ionization	HD-3	NS4-224, NS6-224	HB-5	25
	DCD-135/-90	Heat Fixed Temp/ Rate of Rise	HD-3	NS4-224, NS6-224	HB-5	25
	DFE-135/-190	Heat Fixed Temp	N/A	HSC -224L	HB-62	25

## A.2 Reserved for Future Use

### **A.3 Compatible Notification Appliances**

---

All notification appliance devices determined to be compatible with the synchronization modules shown below are compatible for operation with the FireNET Plus fire alarm control panel under Regulated (Continuous) operation:

<b>Manufacturer</b>	<b>Manufacturer Sync Module</b>	<b>Maximum NAC Load</b>
System Sensor	MDL (Red), MDLW (White)	0.90 A
Wheelock	SM-24-R, DSM-R	0.90 A
Amseco	SMD10-3A	0.90 A

#### **Synchronization**

The FireNET Plus fire alarm control panel is suitable for single and dual circuit synchronization. Synchronization can be performed on NAC channels 1 and 2 of the FireNET Plus. Synchronization is unique to each FireNET Plus panel and cannot be performed across multiple control panels.

NAC devices from Gentex, System Sensor, Amseco, and Wheelock do not require external synchronization modules in order to operate on the FireNET Plus panel. The panel supports these manufacturer protocols internally (Special Application). NAC 1 and NAC 2 are synchronized when operating NAC devices from these manufacturers

### A.3.1 Gentex Compatible NAC Devices

The following devices from Gentex are recommended for use with the FireNET Plus control panel for synchronized applications on NAC 1 and NAC 2:

Gentex	Environment	Model Series	Description	Mount
WSSPK Series	Outdoor	WSSPK24-15/75	Speaker Strobe	Wall
SSPK24WLP Series	Indoor	SSPK24WLP	Speaker Strobe	Wall
SSPKCLP Series	Indoor	SSPK24CLP	Speaker Strobe	Ceiling
Commander4 Series	Indoor	GCC24	Horn Strobe	Ceiling
Commander4 Series	Indoor	GCS24	Strobe	Ceiling
Commander3 Series	Indoor	GEC3-24	Horn Strobe	Wall
Commander3 Series	Indoor	GES3-24	Strobe	Wall
Commander3 Series	Indoor	GEH24	Horn	Wall
Commander2 Series	Indoor	GEC24	Horn Strobe	Wall
Commander2 Series	Indoor	GES24	Strobe	Wall
Commander2 Series	Indoor	GEH24	Horn	Wall
Outdoor Commander Series	Outdoor	WGEC24	Horn Strobe	Wall
Outdoor Commander Series	Outdoor	WGES24	Strobe	Wall
Outdoor commander Series	Outdoor	GEH24	Horn	Wall
GX91/GX93 Series	Indoor	GX93	Mini Horn	Wall

### A.3.2 Amseco Compatible NAC Devices

The following devices from Amseco are recommended for use with the FireNET Plus control panel for synchronized applications on NAC 1 and NAC 2:

Amseco	Environment	Model Series	Description	Mount
Select-A-Strobe/Chime	Indoor	CM24C	Chime	Ceiling
Select-A-Strobe/Chime	Indoor	SCM24C	Chime Strobe	Ceiling
Select-A-Horn	Indoor/Outdoor	H-1224	Horn	Wall
Select-A-Strobe/Horn	Indoor	SH-1224	Horn Strobe	Wall
Select-A-Strobe/Horn	Outdoor	SH-1224WP	Horn Strobe	Wall
Select-A-Strobe/Horn	Indoor	SH24C-177	Horn Strobe	Wall/Ceiling
Select-A-Strobe/Horn	Indoor	SH24C-3075110	Horn Strobe	Wall/Ceiling
Speaker/Strobe Square	Indoor/Outdoor	SSS-2	Speaker Strobe	Wall
Speaker/Strobe Square	Indoor/Outdoor	SSS-8	Speaker Strobe	Wall
Speaker/Strobe Round	Indoor/Outdoor	SSR-2	Speaker Strobe	Wall/Ceiling
Speaker/Strobe Round	Indoor/Outdoor	SSR-8	Speaker Strobe	Wall/Ceiling

Speaker/Strobe Round	Indoor	SSC-2	Speaker Strobe	Wall/Ceiling
Speaker/Strobe round	Indoor	SSC-8	Speaker Strobe	Wall/Ceiling
Select-A-Strobe	Indoor	SL-1224	Strobe	Wall
Select-A-Strobe	Indoor/Outdoor	SL-1224-WP	Strobe	Wall
Select-A-Strobe	Indoor	SL24C-3075110	Strobe	Wall/Ceiling
Select-A-Strobe	Indoor	SL24C-177	Strobe	Wall/Ceiling
Bell/Select-A-Strobe	Indoor	SB24	Bell Strobe	Wall/Ceiling
Select-A-Strobe/Chime	Indoor	SCM24W-153075	Chime Strobe	Wall
Select-A-Strobe/Chime	Indoor	SCM24W-75110	Chime Strobe	Wall
Select-A-Horn	Indoor	H24W	Horn	Wall/Ceiling
Select-A-Strobe/Horn	Indoor	SH24W-1530	Horn Strobe	Wall
Select-A-Strobe/Horn	Indoor	SH24W-75110	Horn Strobe	Wall
Indoor/Outdoor horn/Strobe	Indoor/Outdoor	SHB24-75	Horn Strobe	Wall
Speaker/Strobe	Indoor	SSC25-177	Speaker Strobe	Wall/Ceiling
Select-A-Strobe/Speaker	Indoor	SSC25-3075110	Speaker Strobe	Wall/Ceiling
Speaker/Strobe	Indoor	SSC70-177	Speaker Strobe	Wall/Ceiling
Select-A-Strobe/Speaker	Indoor	SSC70-3075110	Speaker Strobe	Wall/Ceiling
Select-A-Strobe/Speaker	Indoor	SFH45-153075	Speaker Strobe	Wall/Ceiling
Select-A-Strobe/Speaker	Indoor	SFH47-75110	Speaker Strobe	Wall/Ceiling
Select-A-Strobe	Indoor	SL24W-1530	Strobe	Wall
Select-A-Strobe	Indoor	SL24W-75110	Strobe	Wall
Indoor/Outdoor Strobe	Indoor/Outdoor	SLB24-75	Strobe	Wall
Select-A-Strobe	Indoor/Outdoor	SB24	Strobe	Wall/Ceiling
Select-A-Strobe/Horn	Indoor	SH24W-153075	Horn Strobe	Wall
Select-A-Strobe	Indoor	SL24W-153075	Strobe	Wall
Strobe Bell/Horn Plate	Indoor	RSB24-153075	Strobe Bell/Horn Plate	Wall/Ceiling
Strobe	Indoor	RSD24-153075	Strobe	Wall/Ceiling
Select-A-Strobe	Indoor	RSD24-75110	Strobe	Wall/Ceiling
Select-A-Strobe	Indoor	SAD24-153075	Strobe	Wall/Ceiling

### A.3.3 Wheelock Compatible NAC Devices

The following devices from Wheelock are recommended for use with the FireNET Plus control panel for synchronized applications on NAC 1 and NAC 2:

Wheelock	Description	Mount
AMT-12/24	Mutilating – 3 Input	N/A
AMT-241575, AMT-24MCW	Mutilating Strobe – 1575cd or 15, 30, 75, 110cd	Wall
AMT-241575	Mutilating Strobe (NYC) – 1575cd	Wall
AMT-12/24 Audible Only	Mutilating Audible only	N/A
AS-121575, AS-241575	Audible Strobe – 1575cd	Wall
AS-24MCW	Audible Strobe – 15, 30, 75, 110cd	Wall
AS-24MCC	Audible Strobe – 15, 30, 75, 95cd	Ceiling
AS-24MCWH	Audible Strobe – 135, 185cd	Wall
AS-24MCCH	Audible Strobe – 115, 177cd	Ceiling
AH-12, AH-24	Audible	N/A
ASWP-2475	Audible Strobe – 180cd	Wall
AHWP	Audible	Wall
CH70, CH90	Chime	N/A
CH70-241575	Chime – 1575cd	Wall
CH70-24MCW	Chime – 15, 30, 75, 95cd	Wall
CH90-24MCC	Chime – 15, 30, 75, 95cd	Ceiling
CH70-MCWH	Chime – 135, 185cd	Wall
CH90-MCCH	Chime – 115, 177cd	Ceiling
E50-241575W	Speaker Strobe	Wall
E50-MCW	Speaker Strobe – 15, 30, 75, 110cd	Wall
E50-MCWH	Speaker Strobe – 135, 185cd	Wall
E60-24MCC	Speaker Strobe – 15, 30, 75, 95cd	Ceiling
E60-MCCH	Speaker Strobe – 115/177cd	Ceiling
E70A, E70B, E90A, E90B	Speaker Strobe – Amber or Blue lens	N/A
E70-241575	Speaker Strobe – 1575cd	Wall
E70-24MCW	Speaker Strobe – 15, 30, 75, 110cd	Wall
E90-24MCC	Speaker Strobe – 15, 30, 75, 95cd	Ceiling
E70-24MCWH	Speaker Strobe – 135, 185cd	Wall
E90-24MCCH	Speaker Strobe – 115, 177cd	Ceiling
ET70-241575	Speaker Strobe – 1575cd	Wall
ET70-24MCW	Speaker Strobe – 15, 30, 75, 110cd	Wall
ET90-24MCC	Speaker Strobe – 15, 30, 75, 95cd	Ceiling

ET70-24MCWH	Speaker Strobe – 135, 185cd	Wall
ET90-24MCCH	Speaker Strobe – 115, 177cd	Ceiling
ET80-24MCW	Speaker Strobe – Vandal Resist. 15, 30, 75, 110cd	Wall
ET80-24MCWH	Speaker Strobe – Vandal Resist. 135, 185cd	Wall
ET70WP-2475	Speaker Strobe	Wall
HS-24	Audible	N/A
HS4-241575	Audible Strobe – 1575cd	Wall
HS4-24MCW	Audible Strobe – 15, 30, 75, 110cd	Wall
HS4-24MCWH	Audible Strobe – 135, 185	Wall
MIZ-24S	Mini horn – Continuous, Code-3, Sync.	N/A
MT	Multitone	N/A
Mt-121575, MT-241575, MT-24MCW	Multitone Strobe – 1575 or 15, 30, 75, 110cd	Wall
MTWP-2475	Multitone Strobe	Wall
MTWP B or A	Multitone Strobe – Blue or Amber lens	Wall
NH	Audible	N/A
NS-24MCC	Audible Strobe – 15, 30, 75, 95cd	Ceiling
NS-24MCCH	Audible Strobe – 115, 177cd	Ceiling
NS-24MCW	Audible Strobe – 15, 30, 75, 110cd	Wall
NS-12575, NS-241575	Audible Strobe – 1575cd	Wall
RSS-121575	Strobe – 15, 75cd	Wall
RSS-241575, RSSP-241575	Strobe – 15, 75cd	Wall
RSS-24MCW, RSSP-24MCW	Strobe – 15, 30, 75, 110cd	Wall
RSS-24MCC, RSS-24MCCR	Strobe – 15, 30, 75, 95cd	Ceiling
RSS-24MCWH, RSSP-24MCWH	Strobe – 135, 185cd	Wall
RSS-24MCCH, RSS-24MCCHR	Strobe – 115, 177cd	Ceiling
S8, S8-24MCC, S8-24MCCH	Speaker or Speaker Strobe – 8-inch	Ceiling
SA-S90-24MCC	Speaker Strobe – Amplified, 15, 30, 75, 95cd	Ceiling
SA-S70-24MCW	Speaker Strobe – Amplified, 15, 30, 75, 115cd	Wall
STH w/opt Strobe	Cluster Speaker – w/optional DC-MAX Strobe	N/A
STH MCCH	Cluster Speaker – with 115/177cd Strobe	N/A
STH-4R24MCCH110	Cluster Speaker with 3 Strobe	N/A
STx	Strobe – 15, 15/75, 30, 75, 95, 110, 135, 185cd	Wall
STxC	Strobe – 15, 30, 60, 75, 95, 115, 150, 177cd	Ceiling
HSx	Audible Strobe – 15, 15/75, 30, 75, 95, 110, 135, 185cd	Wall
HSxC	Audible Strobe – 15, 30, 60, 75, 115, 150, 177cd	Ceiling
HBx	Audible	Wall
HNxC	Audible	Ceiling

### A.3.4 System Sensor Compatible NAC Devices

The following devices from System Sensor are recommended for use with the FireNET Plus control panel for synchronized applications on NAC 1 and NAC 2:

System Sensor	Environment	Model Series	Description	Mount
SpectrAlert Advance	Indoor	SPS	Speaker Strobe	Wall
SpectrAlert Advance	Indoor	SPSC	Speaker Strobe	Ceiling
SpectrAlert Advance	Outdoor	SPS (K)	Speaker Strobe	Wall
SpectrAlert Advance	Outdoor	SPSC (K)	Speaker Strobe	Ceiling
SpectrAlert Advance	Indoor	P2	Horn Strobe, 2-Wire	Wall
SpectrAlert Advance	Indoor	P4	Horn Strobe, 4-Wire	Wall
SpectrAlert Advance	Indoor	PC2	Horn Strobe, 2-Wire	Ceiling
SpectrAlert Advance	Indoor	PC4	Horn Strobe, 4-Wire	Ceiling
SpectrAlert Advance	Indoor	SC	Strobe	Ceiling
SpectrAlert Advance	Indoor	H	Horn	Wall/Ceiling
SpectrAlert Advance	Outdoor	P2 (K)	Horn Strobe, 2-Wire	Wall
SpectrAlert Advance	Outdoor	P4 (K)	Horn Strobe, 4-Wire	Wall
SpectrAlert Advance	Outdoor	S (K)	Strobe	Wall
SpectrAlert Advance	Outdoor	PC2 (K)	Horn Strobe, 2-Wire	Ceiling
SpectrAlert Advance	Outdoor	PC4 (K)	Horn Strobe, 4-Wire	Ceiling
SpectrAlert Advance	Outdoor	SC (K)	Strobe	Ceiling
SpectrAlert Advance	Outdoor	H (K)	Horn	Wall/Ceiling
SpectrAlert Advance	Indoor	CH	Chime	Wall/Ceiling
SpectrAlert Advance	Indoor	CHS	Chime Strobe	Wall
SpectrAlert	Indoor	CH24MC	Chime Strobe	Wall
SpectrAlert	Indoor	CH1224	Chime	Wall/Ceiling
SpectrAlert	Indoor	SP2x1224MC	Speaker Strobe	Wall
SpectrAlert	Indoor	SP3x1224MC	Speaker Strobe	Wall
SpectrAlert	Outdoor	SP24R1224MCK	Speaker Strobe	Wall
SpectrAlert	N/A	S1224MC	Strobe	Wall
SpectrAlert	N/A	P1224MC	Horn Strobe, 4-Wire	Wall
SpectrAlert	N/A	H12/24	Horn	Wall/Ceiling

## A.4 Compatible 24VDC Devices

---

For proper operation use 24VDC polarized devices. When used on a NAC circuit be sure to use with a Hochiki 10K end of line resistor PN# S2028. When used on the AUX24VDC output the supervision resistor is not necessary.

The AUX24VDC outputs are rated as **Regulated** by UL Laboratories. In this case specific device compatibility is not required. Be sure to verify current loading of the panel when attaching devices to these outputs by using the battery calculator shown in section 2.6 of this manual.

Table A.4 lists 24VDC devices that are compatible with the FireNET Plus fire alarm control panel **Regulated** outputs, though specific compatibility is not required when outputs are rated as **Regulated** by UL.

**Table A.4: Compatible 24VDC Devices with the FireNET Plus Fire Alarm Control Panel**

Manufacturer	Model Number	Type
Hochiki America	FN-4127-IO	16 Channel Input Output Board
	SRA-24	Reflective Beam Detector
	SPB-24N	Beam Detector
	FN-LCD-S	Serial LCD Annunciator
	SOM / SOM-A / SOM-AI	Supervised Output Module
	CZM	Conventional Zone Module
	ASB	Analog Sounder Base
	ASBL	Analog Sounder Base Low Frequency
	DH-98A/AR	Analog Duct Detector
	DH-98P//HV	Conventional Duct Detector
DH-99A/AR	Analog Duct Detector	
Hochiki/Altronix	ULADA Series	NAC Boosters (6, 8, & 10 Amp)
Hochiki/Altronix	ULX Series	AUX 24VDC Power Supplies (2.5, 4, 6, & 10 Amp)
GE/IFS	D1300	RS485 to Fiber Optic Converter (24VDC model)
RSG	DH24 Series	Door Holder Series (24VDC models)



## A.5 Changing the Power Supply to 240VAC operation

When converting the FireNET Plus power supply to 240VAC operation, please follow the directions described in this section. The FireNET Plus can operate with 120VAC or 240VAC input. By default the power supply is configured for 120VAC operation. To change it to 240VAC, follow the steps below:

- 1) Be sure that the FireNET Plus is NOT powered during this procedure!
- 2) Open the display panel to expose the back side of the FireNET Plus circuit board.

3) In the middle of the circuit board you will see a jumper labeled J1. Remove this jumper from the pins. The power supply is now set for 240 VAC operation.

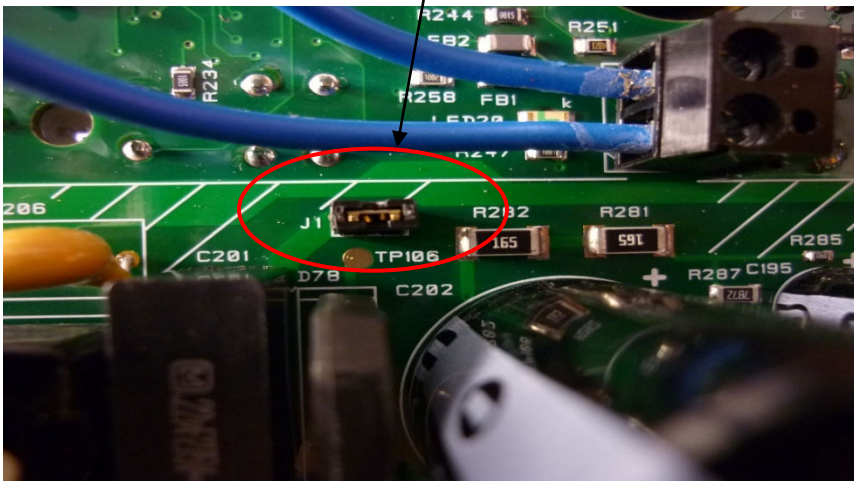
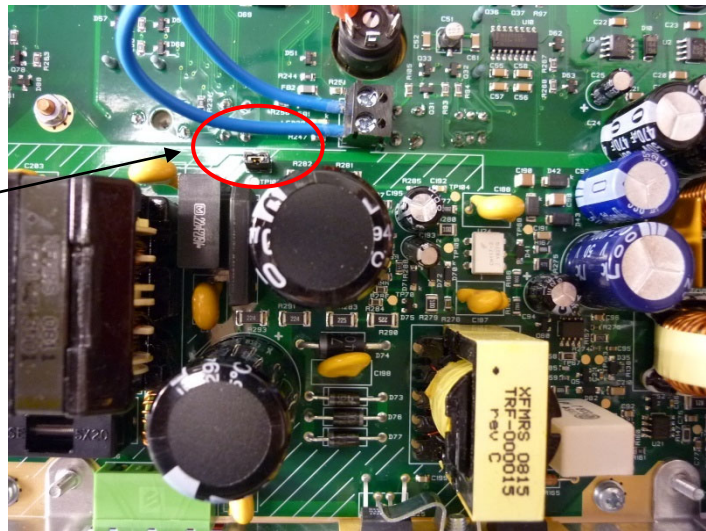

- 4) Close the display panel and secure it with the screw.

**WARNING** – Do NOT apply 240 VAC to the FireNET Plus control panel unless the power supply has been configured to operate at 240 volts! Doing so will damage the panel, requiring it to be returned to the factory for repair!

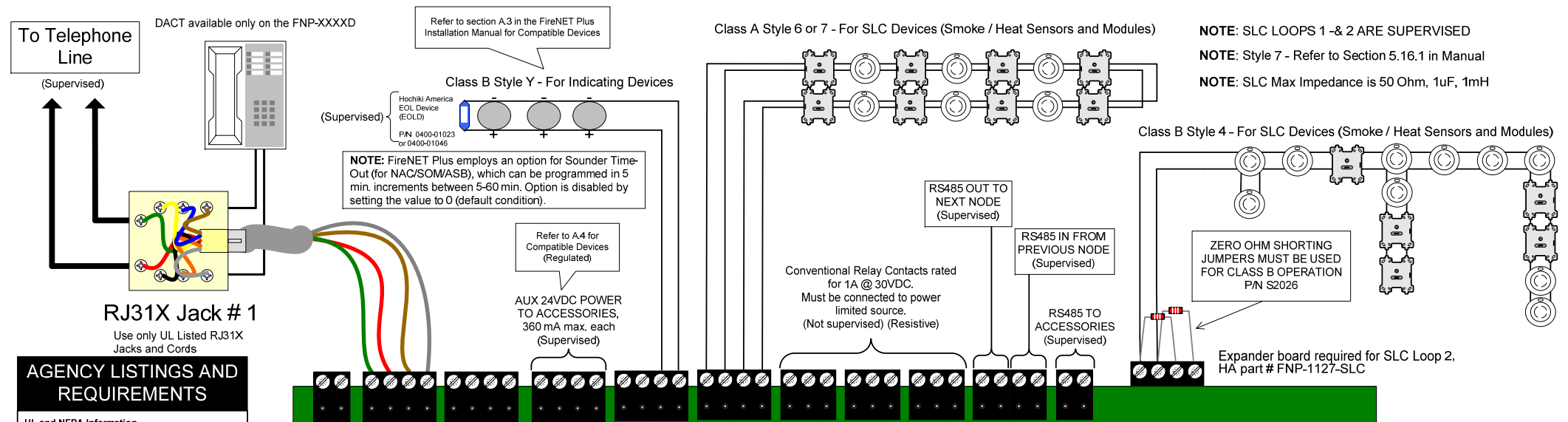

SLC INITIATING DEVICES	
Wire Gauge	Maximum Wire Length for SLC Loop out & return (Class A and B)
18 AWG	1,950 Feet
16 AWG	3,100 Feet
14 AWG	5,000 Feet

**AGENCY LISTINGS AND REQUIREMENTS**

**UL and NFPA Information**  
Install in accordance with NFPA 70, 72 and 13.

The FireNET Plus is suitable as follows:  
- Commercial Protected-Premises Control Unit for Local signaling. Install indoors only in a dry environment.  
- Types of signaling services are automatic, manual, waterfall, & sprinkler supervisory.  
- Style 4, 6, or 7 for Signaling Line Circuits  
- Style Y for Notification Appliance Circuits  
- Non-coded signaling  
- Central Station Service (DACT)  
- Remote Station Service (DACT)  
- Auxiliary Service (Local Energy)  
- UL Releasing Function for Pre-Action with use of SOM-R Module

**F.C.C. Information**  
The FireNET Plus has been verified to comply with FCC Rules Part 15, Class A Operation is subject to the following conditions:  
1. This device may not cause radio interference.  
2. This device must accept any interference received, including any that may cause undesired operation.  
F.C.C. registration number: US:KNTAL00BASA-FACP

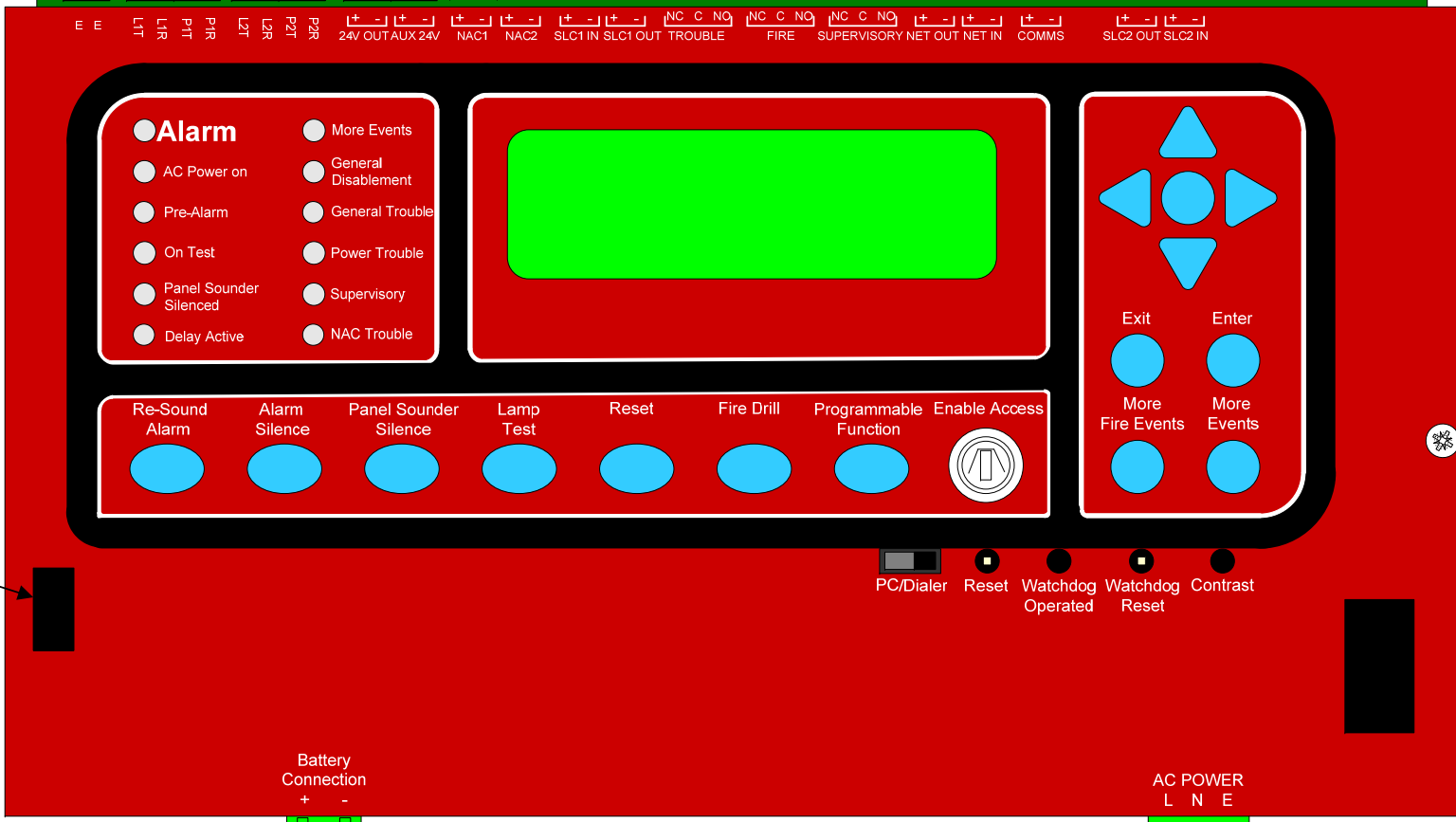

TERMINAL STRIP ELECTRICAL RATINGS FOR MAIN CONTROL UNIT			
Terminal Label	Description	Rating	
		Voltage	Current
E	Ground	0VDC	-
L1T	Telco Line 1	48VDC	30mA
L1R	Telco Line 1	48VDC	30mA
P1T	Phone 1	48VDC	30mA
P1R	Phone 1	48VDC	30mA
L2T	Telco Line 2	48VDC	30mA
L2R	Telco Line 2	48VDC	30mA
P2T	Phone 2	48VDC	30mA
P2R	Phone 2	48VDC	30mA
24V OUT +	Aux Power	24VDC	360mA
24V OUT -	Aux Power	24VDC	360mA
AUX 24V +	Aux Power	24VDC	360mA
AUX 24V -	Aux Power	24VDC	360mA
NAC1 +	NAC Circuits 1 & 2	24VDC	2.3 A
NAC1 -		24VDC	2.3 A
NAC2 +		24VDC	2.3 A
NAC2 -		24VDC	2.3 A
SLC1 IN +	SLC Loop 1	32VDC	250mA
SLC1 IN -		32VDC	250mA
SLC1 OUT +		32VDC	250mA
SLC1 OUT -		32VDC	250mA
NC	Trouble Relay	30VDC	1 A
C		30VDC	1 A
NO		30VDC	1 A
NC	Fire Relay	30VDC	1 A
C		30VDC	1 A
NO		30VDC	1 A
NC	Supervisory Relay	30VDC	1 A
C		30VDC	1 A
NO		30VDC	1 A
NET OUT +	Network Out	12VDC	100mA
NET OUT -		12VDC	100mA
NET IN +	Network In	12VDC	100mA
NET IN -		12VDC	100mA
COMMS +	COMMS Bus	12VDC	100mA
COMMS -		12VDC	100mA
SLC2 OUT +	SLC Loop 2 (optional)	32VDC	250mA
SLC2 OUT -		32VDC	250mA
SLC2 IN +		32VDC	250mA
SLC2 IN -		32VDC	250mA

**RS232 Data port / PC Port**  
May be connected to a Remote Annunciator with EMS Graphix and used as a Supplementary remote annunciator. The connection between PC port and Computer must be within 20 ft. in the same room and in conduit. PC / Dialer switch must always be in PC Position.

**WARNING**

THIS UNIT INCLUDES AN OPTIONAL ALARM VERIFICATION FEATURE that will result in a delay of the system alarm signal from the indicated circuits. The total delay time (control plus smoke detectors) shall not exceed 60 seconds. No other smoke detector shall be connected to these circuits unless approved by the local Authority Having Jurisdiction.

\*Zone(s) where alarm verification is used

Programmed Delay is 60 seconds by default. The delay is programmable from 5 - 60 seconds.

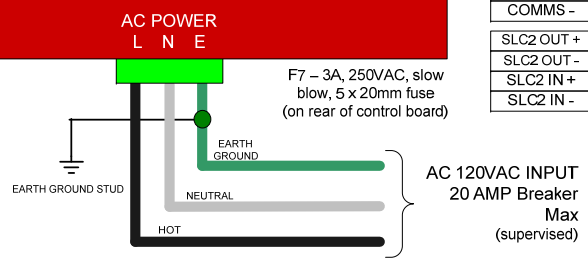
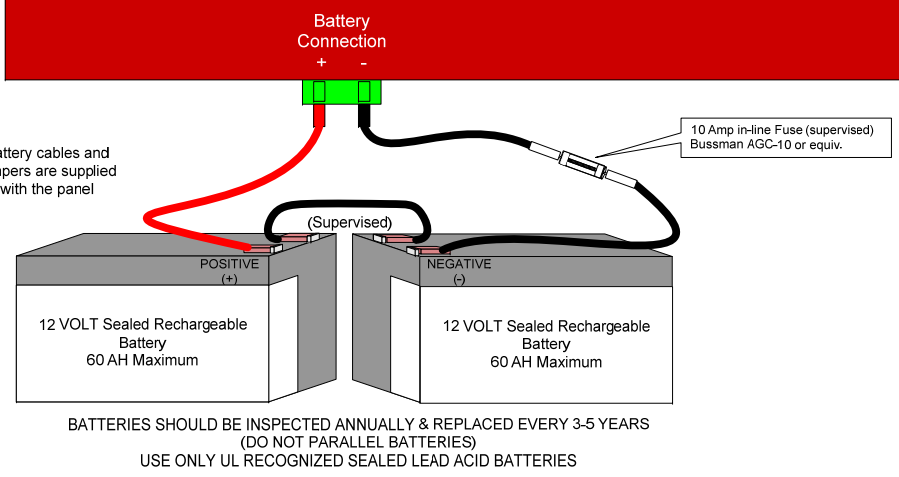

All circuits are inherently Power Limited except AC/Battery inputs and telephone lines.

All Supervised Circuits are identified.

TERMINAL STRIP ELECTRICAL RATINGS FOR THE POWER SUPPLY				
Connector	Terminal	Description	Rating	
			Voltage	Current
TB6	G	Earth Ground	N/A	N/A
	N	AC Neutral	120VAC, 50/60Hz	2.1A
	L	AC Line	120VAC, 50/60Hz	1.1A
			240VAC, 50/60Hz	1.1A
TB3		+ Battery	+24VDC	5A Max
		- Battery	DC Common	5A Max

HOCHIKI AMERICA CORPORATION

This Product shall be installed in accordance with the FireNET PLUS Installation Manual, PN # 1700-10840

Version # 1.074 Issued: June 2016

# FireNET PLUS WIRING DIAGRAM

P/N 1700-04520 DATE June 2016 V1.07

## **Appendix C - WARRANTY**

Hochiki America Corporation manufactured equipment is guaranteed to be free from defects in materials and workmanship for a period of one (3) year from date of original shipment. HOCHIKI will repair or replace, at its option, any equipment which it determines to contain defective material or workmanship. Said equipment must be shipped to HOCHIKI prepaid. Return equipment will be prepaid by HOCHIKI. We shall not be responsible to repair or replace equipment which has been repaired by others, abused, improperly installed, altered or otherwise misused or damaged or exposed to conditions outside the products specifications in any way. Unless previously contracted by HOCHIKI, HOCHIKI will assume no responsibility for determining the defective or operative status at the point of installation, and will accept no liability beyond the repair or replacement of the product at our factory service department. Please contact HOCHIKI's Sales department for proper procedure for claims and return of merchandise.

**Hochiki America Corporation  
7051 Village Drive, Suite 100  
Buena Park, CA 90621-2268  
1-800-845-6692  
technicalsupport@hochiki.com**

