

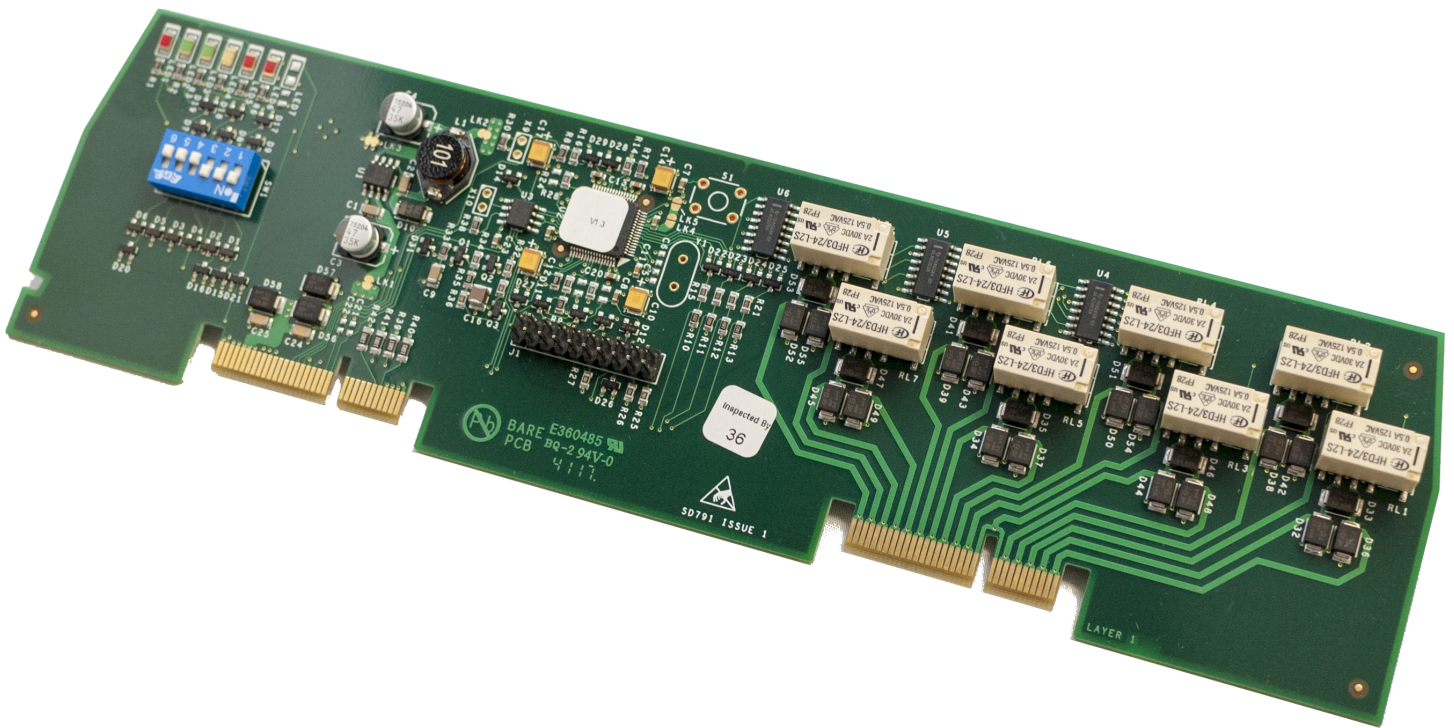

8 Channel Relay Panel Module (S791) Information Guide



CONTENTS

Contents	2
Compliance	4
Underwriters Laboratories (UL)	4
FCC	4
Installation	4
Introduction	5
Technical Support	5
Return Material Authorization (RMA)	5
Warranty Service	6
Advanced Replacements	6
Overview	7
Use Case Examples	7
Package Contents	8
Installation	9
Before You Begin	10
Setting the Address	10
Placement	10
Wiring	13
Testing the Installation	14
Configuration	15
UL Compliance Limitations	16
Specifications	17
Electrical	17

Cabling	17
Operating Environment	17
Physical Specifications	17
Index	18

COMPLIANCE

Underwriters Laboratories (UL)

Fire Alarm Subassembly
Hochiki America Corporation

FCC

This equipment has been tested and found to comply with the limits for a Class A digital device, pursuant to Part 15 of the FCC Rules. These limits are designed to provide reasonable protection against harmful interference when the equipment is operated in a commercial environment. This equipment generates, uses, and can radiate radio frequency energy and, if not installed and used in accordance with the Installation Manual, may cause harmful interference to radio communications. Operation of this equipment in a residential area is likely to cause harmful interference in which case the user will be required to correct the interference at his own expense. Any changes or modifications not expressly approved by Hochiki America Corporation could void the user's authority to operate this equipment under the rules and regulations of the FCC.

Operation is subject to the following two conditions:

- (1) This device may not cause harmful interference, and
- (2) This device must accept any interference received, including interference that may cause undesired operation.

Installation

Install this product in accordance with NFPA 13, NFPA 72, NFPA 70, and NEC 70 and all local codes.

All field wiring should be installed using fire rated cables according to the NFPA 72. Riser conductors shall be installed in accordance with the survivability from attack by fire requirements in National Fire Alarm Code, NFPA 72, Section 12.3. Riser conductors shall employ either a 2 hour rated cable system, or meet requirements approved by the AHJ.

INTRODUCTION

Technical Support

For technical support, contact Hochiki America at 800.845.6692 or technicalsupport@hochiki.com. Hochiki technical support is available Monday through Friday, 7:00AM to 5:00PM, PST.

Prior to contacting technical support, have the following information available:

- Product part number
- Purchase order or order number
- Product serial number
- Current function of the product
- Expected function of the product
- Installation of the product

Return Material Authorization (RMA)

Contact Technical Support to obtain an RMA for any product to be returned. Returns will not be accepted without an accompanying RMA number. An RMA number is assigned when:

- Tech Support acknowledges a possible product failure.
- A product was damaged during shipping
- An incorrect product was shipped
- An order was placed using an incorrect part number *
- An order was placed using an incorrect part quantity *
- An order is no longer required *

* Restocking fees may apply.

All returned products are tested to confirm operating failures experienced in the field. If the product is found to be functional, contractors must absorb expenses for return shipping, as well as the cost and shipping of the advanced replacement product.

Prominently display the RMA number on all packages sent for return.

Ship all return products to:

Attention: RMA # _____
Hochiki America

7051 Village Park Drive, Suite 100
Buena Park, CA 90621

Warranty Service

Technical Support can replace or repair a defective product when the original purchase is within the warranty period defined in the sales contract. Check your contract for more information, or contact your sales representative about your specific warranty period.

Advanced Replacements

Products that fail to operate in the field can be replaced quickly using the advanced replacement process. The advanced replacement process is available to all contractors who maintain an acceptable line of credit.

Initiate the advanced replacement process by requesting an RMA number from a Tech Support representative. Advanced replacements can be shipped to your location when the product is covered under warranty and when a replacement product is in stock.

- Advanced replacements can be expedited at the request of the contractor. Shipping costs associated with this process are the responsibility of the contractor.
- Products returned using the advanced replacement process must be received within 30 days of the RMA issue date.

OVERVIEW

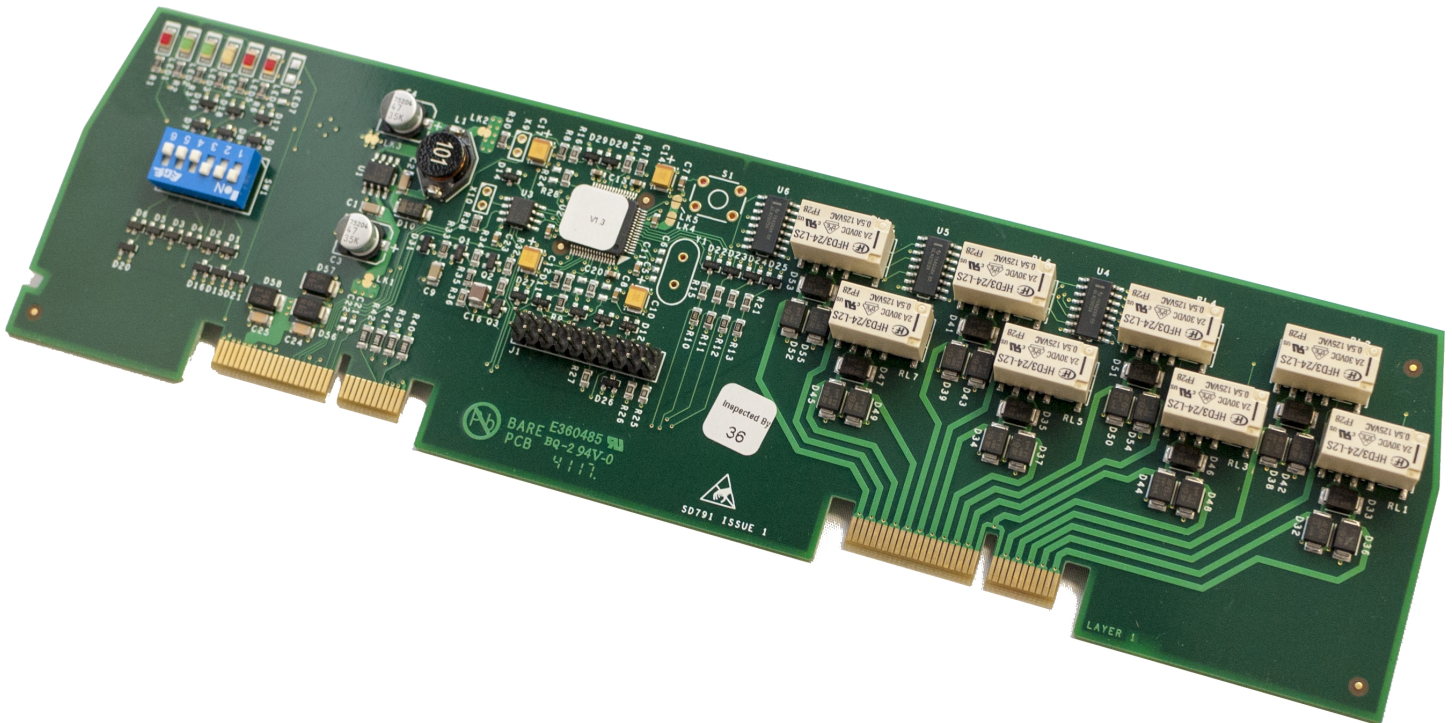

8 Channel Relay Panel Module (S791)

The 8 Channel Relay Panel Module has 8 voltage-free, unsupervised SPST Normally-Open relay contacts, each of which can be individually programmed. All outputs are configurable in the same way as devices connected to the loops and all may be acted upon by cause and effect logic.

Use Case Examples

The 8 Channel Relay Panel Module are typically used in applications which require more than the four standard relay outputs, such as signaling to other systems or plant control.

This module can be used to interface the L@titude panel to a NAC extender or Voice Evacuation system, by providing

- outputs from the panel to control various NAC or Voice Evacuation outputs.

This module can be used to interface the L@titude panel to a secondary panel or releasing panel, by providing

- outputs from the panel to activate NAC outputs on these panels.

Package Contents

- (1) Installation sheet
- (1) Wiring Terminal Labels
- (1) S791 8 Channel Relay Panel Module

INSTALLATION

This section provides instructions for connecting cables, mounting, and testing the 8 Channel Relay Panel Module for installation.

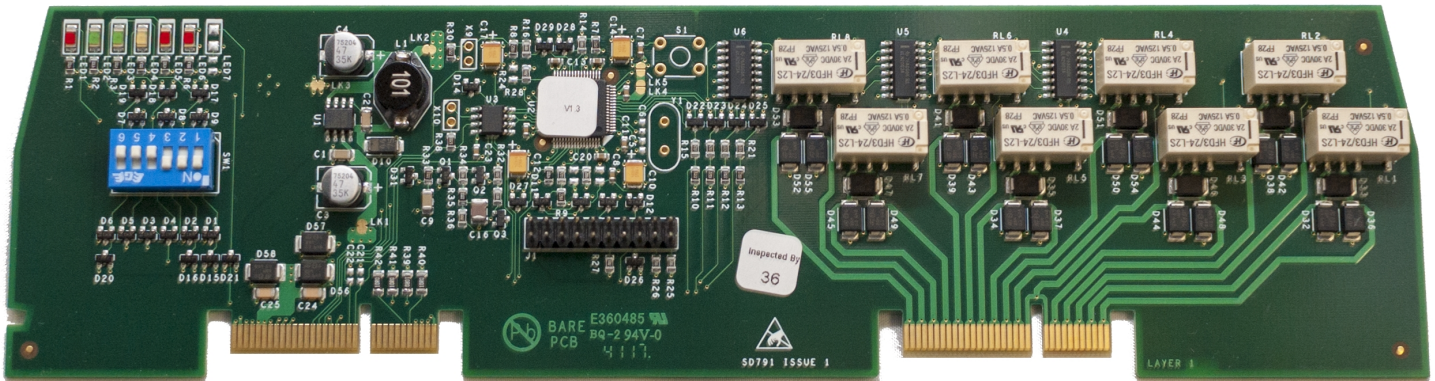

- Using Loop Explorer 2, add the panel module to the existing configuration and configure it as required for the system. For detailed information on the configuration settings, refer to the [Configuration](#) section.
- Notify the monitoring center and location security that the FireNET L@titude Fire Alarm Control Panel will be temporarily out of service.
- Remove the module from its packaging and check its contents.
- Set the address of the module as configured in Loop Explorer 2. Refer to [Setting the Address](#) for details.
- Determine the slot (E or higher) where the panel module will be installed and place the provided sticker label on the corresponding field terminals.
- Connect field wiring.
- Transfer the new configuration from Loop Explorer 2 into the panel.
- Wait for the "Sending configuration to panel" (in LE2) and "Saving configuration" (on the panel) steps to complete.
- Remove AC and battery power from the panel.
- Remove the black plastic cover.
- Install the module into selected slot on the Main Back Board or an Extension Board of the panel.
- Restore AC and battery power.
- Wait for the panel start-up process to complete. Refer to the **FireNET L@titude Fire Alarm Control Panel Installation Manual (MAN-1431HA)** for more information.
- Test communication from the panel via the [LED Status Indicators](#).
- Resolve any troubles related to the new field wiring.
- Activate each circuit and verify that all connected devices function properly.
- Replace the black plastic cover.

Install this product in accordance with NFPA 72, the National Electrical Code, and all local codes.

WARNING! The module must be installed by personnel familiar with electronic components. Electronic components within the module are vulnerable to damage from electrostatic discharge. Ground straps must be worn by installers before handling to prevent electrostatic discharge damage.

Before You Begin

The following item is not included with the FireNET L@titude Fire Alarm Control Panel, but is required for the installation:

- A Ground Strap is required for handling circuit boards.

Setting the Address

Panel modules should use addresses 1-8. Each panel module of the FireNET L@titude Fire Alarm Control Panel must contain a unique setting before being connected to the Main Back Board. The binary setting of the DIP switch sets the specific address for the panel module. The numeric order of the address setting between modules does not impact operation, but each panel module must be assigned a separate / unique address.

The black portion of the DIP switch identifies the switch actuator.

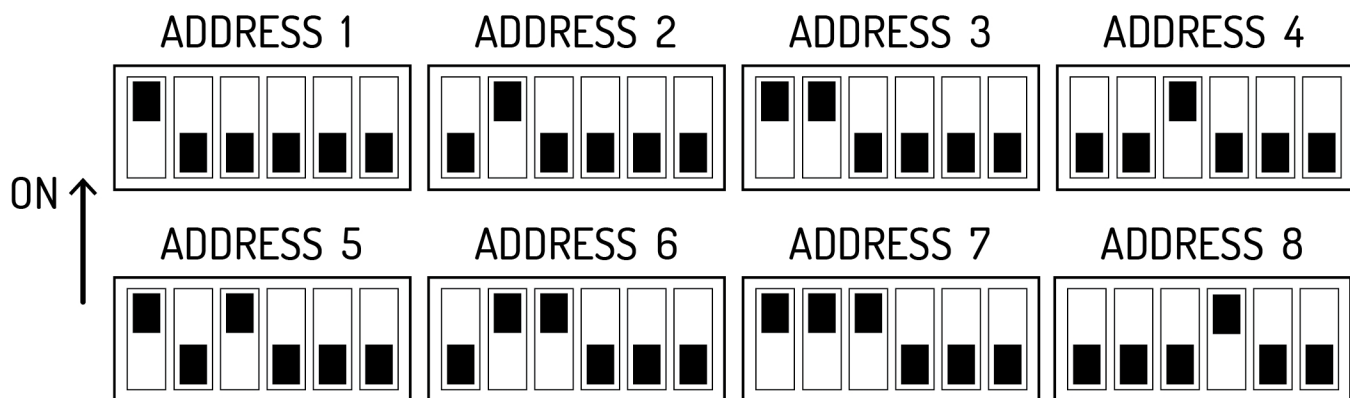

Placement

To install modules on the FireNET L@titude Fire Alarm Control Panel:

1. Disconnect AC power and standby batteries prior to performing the module installation.
2. Remove the retaining screw and plastic cover.



3. Remove the panel module from the protective packaging using adequate electrostatic protection.
4. Point the conductor side of the panel module toward the backplate.
5. Insert the notched end of the panel module in the metal guide notch of the backplate at an angle, as shown.

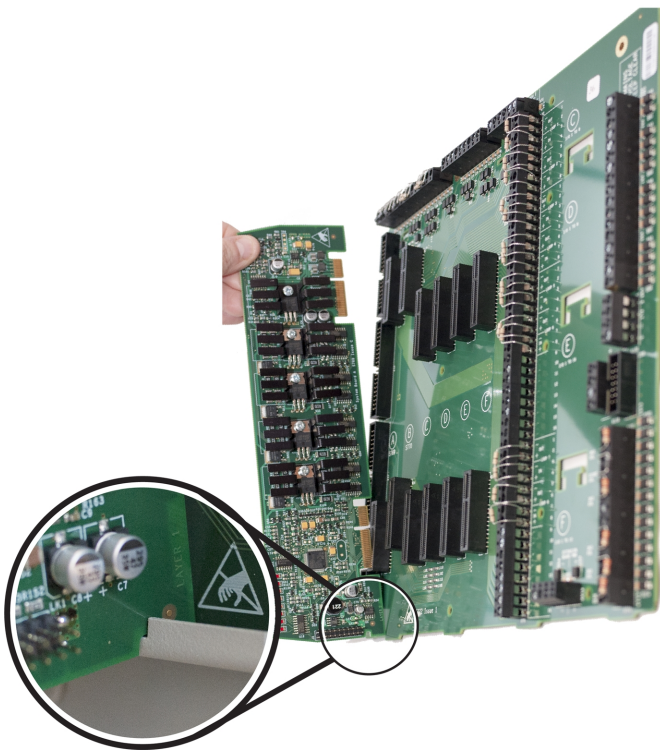

The photo above is an example of panel module placement and may not be representative of the specific module and slot placement described in this guide. Refer to the checklist above for details on placement.

6. Rotate the panel module until all conductors are securely inserted into connectors of the Main Back Board.
7. Replace the cover onto the Main Back Board.
8. Reconnect the batteries and restore AC power.

Wiring

Most external equipment that can be operated by a dry contact can be controlled by a channel of the 8 Channel Relay Panel Module. Do not exceed contact rating of 30 V DC @ 1 Amp. The source connected to each relay must be power-limited.

Examples of the external equipment are:

- NAC extender
- Voice Evacuation System
- Plant Control
- Elevator Recall
- Secondary Fire Panel Inputs
- Releasing System NACs
- Security and Access Control Systems
- Smoke Control Systems

NOTE Because these contacts are not supervised by the panel, they may need to be supervised by the external equipment.

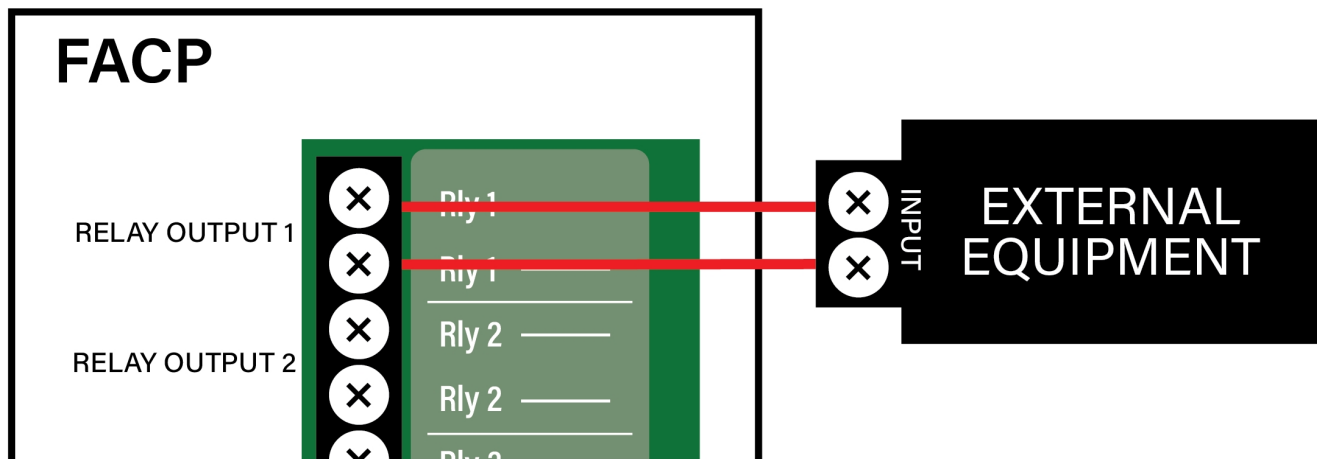

Testing the Installation

1. Confirm communication from the panel via the LED status indicators. LED indicators provide diagnostic information to identify communication.
2. Resolve any troubles related to the new connections.
3. Activate each circuit and verify that all connected devices function properly.

LED Label	Name	Color	Description
LED 1	Heartbeat	Red	Flashes every 2 seconds when the board is operating.
LED 2	Rx Comms	Green	Flashes every 2 - 3 seconds when the module is receiving data from the panel.
LED 3	Tx Comms	Green	Flashes every 2 - 3 seconds when the module is transmitting data to the panel.
LED 4	Trouble	Yellow	Flashes every 2 seconds when one or more outputs have a trouble condition.
LED 5	Input Active LED	Red	Not Used
LED 6	Output Active LED	Red	Flashes every 2 seconds when one or more outputs are active (low).

CONFIGURATION

The 8 Channel Relay can be configured via LE2 or the Panel GUI.

1. Select the desired **Output Options**. This selection will activate the circuit when the selected event(s) occur.
2. Set whether the output will be **Silenceable**. Each channel is configurable in reaction to the Alarm Silence button on the front panel. Check the box if the channel should return to normal standby when Alarm Silence is active. If this box is checked, the **Second Delay** field is displayed.
3. Each output circuit is SPST. Outputs are normally-open (N.O.) and close upon activation. Selecting **Output Invert** will set the output circuit to be normally-closed (N.C.); inverted outputs open upon activation. During times of complete power loss (loss of both normal and backup power) all outputs will open regardless of their configuration settings. Inverting an output does not change the quiescent current consumption of the panel module.
4. **Ignore Global Delays**. This setting controls the delay of the activation of the output. If unchecked, it will activate based on the Global Delay settings in the Panel Settings. If checked, it will activate based on the settings in the **First Delay** and **Second Delay** fields. **Second Delay** is only visible if the output is silenceable. For UL compliance, both delays must be set to 0.

NOTE If checked,

- the initial activation of the output will be delayed based on the settings in the First Delay field.
 - if the output is silenceable, subsequent re-sounding of the output will be delayed based on the settings in the Second Delay field.
-

5. Enter a **Duration** to select how long an output will be active. If set to 0, it will remain active until the system is reset or silenced (configuration-dependent). For UL compliance, this field should be set to 0.
6. Set the **Location Text**, up to 80 characters.
7. Use the **Map to Zone** field to set the zone number for the circuit. Allowable values are 0-2000.

UL Compliance Limitations

In order for the product to comply with the requirements in the **Standard for Control Units and Accessories for Fire Alarm Systems, UL 864 10th Edition**, certain programming features or options must be limited to specific values or not used at all as indicated below.

Field	Configurable Range	UL Permitted Value / Range
First Delay	0-10 minutes	0 minutes
Second Delay	0-10 minutes	0 minutes
Duration	0 seconds - 23 hours, 59 minutes, 50 seconds	0 seconds

SPECIFICATIONS

Electrical

Supply Voltage	24 V DC
Quiescent Current Consumption	15 mA
Maximum Current Consumption	25mA (during relay switching)
Output Contact Rating	30 V DC 1 Amp Resistive The source connected to each relay must be power-limited.
Output Type	SPST Normally-Open Contact

Cabling

Cable Capacity	2.5mm ² per terminal
----------------	---------------------------------

Operating Environment

Dry indoor use only.

Temperature Range	-5°C - 49°C or 23°F - 120°F
Relative Humidity	Up to 95%, non-condensing

Physical Specifications

Dimensions	234.6mm x 62.8mm or 9¼" x 2½"
------------	-------------------------------

INDEX

C

Cabling 17

Class A 4

D

DIP Switch 10

H

Heartbeat 14

L

Loop Explorer 2 9

M

Main Back Board 9

N

NAC 7, 13

S

Standby Batteries 11

T

Terminals 9